

CMPDM8002A
SURFACE MOUNT
P-CHANNEL
ENHANCEMENT-MODE
SILICON MOSFET



www.centrasemi.com



SOT-23 CASE

DESCRIPTION:

The CENTRAL SEMICONDUCTOR CMPDM8002A is an Enhancement-mode P-Channel Field Effect Transistor, manufactured by the P-Channel DMOS Process, designed for high speed pulsed amplifier and driver applications.

MARKING CODE: C802A

FEATURES:

- Low $r_{DS(ON)}$
- Low $V_{DS(ON)}$
- Low threshold voltage
- Fast switching
- Logic level compatibility

APPLICATIONS:

- Load/Power switches
- Power supply converter circuits
- Battery powered portable equipment

MAXIMUM RATINGS: ($T_A=25^\circ\text{C}$)

Drain-Source Voltage
Drain-Gate Voltage
Gate-Source Voltage
Continuous Drain Current
Continuous Source Current (Body Diode)
Maximum Pulsed Drain Current
Maximum Pulsed Source Current
Power Dissipation
Operating and Storage Junction Temperature
Thermal Resistance

SYMBOL

V_{DS}	50
V_{DG}	50
V_{GS}	20
I_D	280
I_S	280
I_{DM}	1.5
I_{SM}	1.5
P_D	350
T_J, T_{stg}	-65 to +150
θ_{JA}	357

UNITS

V
V
V
mA
mA
A
A
mW
$^\circ\text{C}$
$^\circ\text{C/W}$

ELECTRICAL CHARACTERISTICS: ($T_A=25^\circ\text{C}$ unless otherwise noted)

SYMBOL	TEST CONDITIONS	MIN	MAX	UNITS
I_{GSSF}, I_{GSSR}	$V_{GS}=20\text{V}, V_{DS}=0$		100	nA
I_{DSS}	$V_{DS}=50\text{V}, V_{GS}=0$		1.0	μA
I_{DSS}	$V_{DS}=50\text{V}, V_{GS}=0, T_J=125^\circ\text{C}$		500	μA
$I_{D(ON)}$	$V_{GS}=10\text{V}, V_{DS}=10\text{V}$	500		mA
BV_{DSS}	$V_{GS}=0, I_D=10\mu\text{A}$	50		V
$V_{GS(th)}$	$V_{DS}=V_{GS}, I_D=250\mu\text{A}$	1.0	2.5	V
$V_{DS(ON)}$	$V_{GS}=10\text{V}, I_D=500\text{mA}$		1.5	V
$V_{DS(ON)}$	$V_{GS}=5.0\text{V}, I_D=50\text{mA}$		0.15	V
V_{SD}	$V_{GS}=0, I_S=115\text{mA}$		1.3	V
$r_{DS(ON)}$	$V_{GS}=10\text{V}, I_D=500\text{mA}$		2.5	Ω
$r_{DS(ON)}$	$V_{GS}=10\text{V}, I_D=500\text{mA}, T_J=125^\circ\text{C}$		4.0	Ω
$r_{DS(ON)}$	$V_{GS}=5.0\text{V}, I_D=50\text{mA}$		3.0	Ω
$r_{DS(ON)}$	$V_{GS}=5.0\text{V}, I_D=50\text{mA}, T_J=125^\circ\text{C}$		5.0	Ω

R1 (27-January 2010)

CMPDM8002A
SURFACE MOUNT
P-CHANNEL
ENHANCEMENT-MODE
SILICON MOSFET



ELECTRICAL CHARACTERISTICS - Continued: ($T_A=25^\circ\text{C}$ unless otherwise noted)

SYMBOL	TEST CONDITIONS	MIN	MAX	UNITS
g_{FS}	$V_{DS}=10\text{V}$, $I_D=200\text{mA}$	200		mS
C_{rss}	$V_{DS}=25\text{V}$, $V_{GS}=0$, $f=1.0\text{MHz}$		7.0	pF
C_{iss}	$V_{DS}=25\text{V}$, $V_{GS}=0$, $f=1.0\text{MHz}$		70	pF
C_{oss}	$V_{DS}=25\text{V}$, $V_{GS}=0$, $f=1.0\text{MHz}$		15	pF
t_{on} , t_{off}	$V_{DD}=30\text{V}$, $V_{GS}=10\text{V}$, $I_D=200\text{mA}$, $R_G=25\Omega$, $R_L=150\Omega$		20	ns

SOT-23 CASE - MECHANICAL OUTLINE

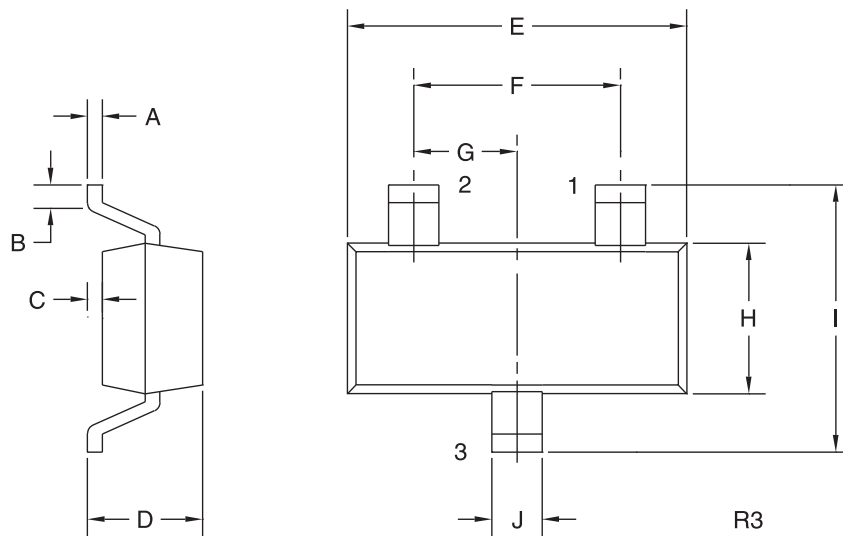

LEAD CODE:

- 1) Gate
- 2) Source
- 3) Drain

MARKING CODE: C802A

SYMBOL	DIMENSIONS			
	INCHES		MILLIMETERS	
	MIN	MAX	MIN	MAX
A	0.003	0.007	0.08	0.18
B	0.006	-	0.15	-
C	-	0.005	-	0.13
D	0.035	0.043	0.89	1.09
E	0.110	0.120	2.80	3.05
F	0.075		1.90	
G	0.037		0.95	
H	0.047	0.055	1.19	1.40
I	0.083	0.098	2.10	2.49
J	0.014	0.020	0.35	0.50

SOT-23 (REV: R3)

R1 (27-January 2010)