

# MAXIM

## MAX3657 Evaluation Kit

### General Description

The MAX3657 evaluation kit is a fully assembled chip-on-board electrical demonstration kit that provides easy evaluation of the MAX3657 155Mbps +3.3V transimpedance amplifier.

Note that the MAX3657 Evaluation Kit provides an electrical interface to the IC that is similar, but not exactly the same as a photodiode.

### Features

- ◆ Easy +3.3V Electrical Evaluation of the MAX3657
- ◆ Fully Assembled and Tested
- ◆ EV Kit Designed for 50Ω Interfaces

### Component List

DESIGNATION	QTY	DESCRIPTION
C2 C23	2	0.01μF ± 5% Ceramic Capacitor (0201) - Do not Install
C3	1	10μF ±10% tantalum capacitor Do Not Install
C4	1	0.9pF ± .075pF Ceramic Capacitor (0402)
C5 C100	2	0.01μF ± 10% Ceramic Capacitor (0402)
C6, C7, C24, C27	4	1μF ± 5% Ceramic Capacitor (0402) Do Not Install
C8, C9, C13, C14, C96, C98, C118, C119	8	1μF ± 5% Ceramic Capacitor (0402)
C17, C99	2	10μF ±10% tantalum capacitor
C97	1	0.4pF ± 0.05pF Ceramic Capacitor (0402)
J3 J4 J5, J22 J26 J27	6	SMA connectors (edge-mount, round)
J19, J23, J24, J25	4	SMA connectors (edge-mount, round) Do not Install
JU3, JU4, JU5, JU6	4	2-pin headers (0.1in centers)
L1	1	56nH inductors (0805) Coilcraft CS-560XKBC Do Not Install
L2 L30	2	56nH inductors (0805) Coilcraft CS-560XKBC

### Ordering Information

PART	TEMP. RANGE	IC PACKAGE
MAX3657EVKIT	-40°C to +85°C	Dice

### Component Suppliers

SUPPLIER	PHONE	FAX
AVX	843-444-2863	843-626-3123
Coilcraft	847-639-6400	847-639-1469
Digi-Key	218-681-6674	218-681-3380
EF Johnson	402-474-4800	402-474-4858
Murata	415-964-6321	415-964-8165

**Note:** Please indicate that you are using the MAX3657 when ordering from these suppliers.

DESIGNATION	QTY	DESCRIPTION
R2, R98	2	49.9Ω ±1% resistor (0402)
R3, R4 R120, R121	4	100Ω ±1% resistor (0402)
R5 R100	2	10kΩ ±1% resistor (0402)
R6	1	1kΩ ±1% resistor (0402)
R7, R38	2	499Ω ±1% resistor (0402)
R28-R29 R33-R34	4	100Ω ±1% resistor (0402) Do Not Install
R31	1	1kΩ ±1% resistor (0402) Do Not Install
R99 R102 R103	3	4.99kΩ ±1% resistor (0402)
TP2, TP4, TP5, TP6 TP8, TP9, TP10 TP13-TP14, TP19	10	TESTPOINT DIGI-KEY 5000K-ND
TP1, TP18, TP11, TP12	4	TESTPOINT DIGI-KEY 5000K-ND Do Not Install
U1	1	MAX3657 ETC 12 QFN
U2	1	MAX3657 DIE
U3	1	User Supplied 4 PIN TO CAN
U4	1	User Supplied 5 PIN TO CAN

# MAX3657 Evaluation Kit

## Quick Start

### Test Equipment Required

- +3.3V power supply with 100mA current capability
- Signal-source, 155Mbps minimum capability
- Oscilloscope with at least 100MHz performance

### Procedure

This procedure will set up the 12 Pin QFN section of the evaluation board for 155Mbps operation.

- 1) Connect a signal source to J26 (IN). Set the signal amplitude to 250mV<sub>P-P</sub> (Corresponding to 250μA<sub>P-P</sub> current into the TIA). Set the data rate to 155Mbps.
- 2) Apply 150μA to the DC\_IN test point (TP10) using a constant current source to emulate the DC component of the input signal. A voltage source connected from TP10 to GND may be used if a constant current source is not available.
- 3) Connect OUT+ (J22) and OUT- (J27) to the 50Ω inputs of a high-speed oscilloscope.
- 4) Remove the shunt from JU6 to enable the DC cancellation loop.
- 5) Install the shunt on JU5 to enable the average current monitor.
- 6) Connect a 3.3V supply to the supply terminal (TP 13) and to the GND terminal.
- 7) The differential signal at the oscilloscope should be approximately 150mV<sub>P-P</sub>.

## Detailed Description

The MAX3657 accepts a DC-coupled input from a high-speed photodiode, for optical modulation amplitudes ranging from -38dBm to 0dBm. The MAX3657 evaluation board facilitates characterization of the MAX3657 TIA with or without a photodiode. The MAX3657 comes from the factory with the die attached and 12 pin QFN sections completely assembled. The user must assemble the TO header sections, if used.

### Die Attached Section

The die-attached section provides a simple circuit for emulating a photodiode current input. The connector at IN (J1) is terminated with 50Ω to ground. Signal voltage applied to the evaluation kit's input is AC coupled to a resistance in series with the MAX3657's input, creating an input signal current. Photodiode DC current can be emulated by injecting DC current into the DC\_IN pin.

### 12 Pin QFN Section

The 12 pin QFN section provides photodiode emulation using similar circuitry as the die-bonded section. An optional TO assembled photodiode interface is also provided. To use a TO mounted photo diode, remove R38, R7, and C4. Figure 2 shows a typical mounting scheme for a photo diode in a TO header.

### 4 and 5 Pin TO Header Layout

The TO header assembly layout provides a user-assembled interface for evaluation of 4 and 5 pin TO headers. (See the MAX3657 datasheet for a suggested TO header layout.)

### Test Equipment Interface

The MAX3657 outputs are back terminated with 100 ohms. To facilitate interface with 50Ω equipment, the MAX3657 EV Kit places external 100Ω termination resistors in parallel with each output so that the EV Kit will match a 50Ω environment.

Note that the output load has a direct effect on the overall gain and output signal swing. Because of the external 100Ω resistors, the overall gain is reduced by 50%. If matching a 50Ω environment is not critical, higher gain can be achieved by increasing the load resistance.

### Photodiode Emulation

Use the following procedure to emulate the high-speed current signal generated by a photodiode:

Select the desired optical power (PAVE in dBm) and extinction ratio (re).

Calculate the average current (IAVE in Amps) as follows:

$$I_{AVG} = \frac{10^{(PAVE/10)}}{1000} \rho$$

where ρ is photodiode responsivity in A/W

Calculate the AC signal current (I<sub>INPUT</sub> in Amps<sub>P-P</sub>) as follows, and adjust the signal generator to obtain it:

$$I_{INPUT} = 2I_{AVE} \frac{(re-1)}{(re+1)}$$

For example, to emulate a signal with an average power of -25dBm and an extinction ratio of 8.

-25dBm optical power will produce 2.7μA of average input current (assume a photodiode responsivity of 0.85A/W). Install a current meter between an external DC source and the DC\_IN test point. Adjust the source to provide 2.7μA.

The signal amplitude is  $2I_{AVE}(re-1)/(re+1) = 4.2\mu A$ . To generate this current through the two 4.99kΩ series input resistors and the 800Ω internal resistance, set the signal source to produce an output level of 45mV<sub>P-P</sub>.

### Noise measurements

Remove the input resistors and shunt capacitor before attempting noise measurements. Be very careful when working around the exposed bond wires of the die bonded section. With the input resistors and shunt capacitor removed, the total capacitance at the IN pin is approximately 0.25pF for the die-attached section and about 0.5pF for the QFN section.

# MAX3657 Evaluation Kit

Evaluate: MAX3657

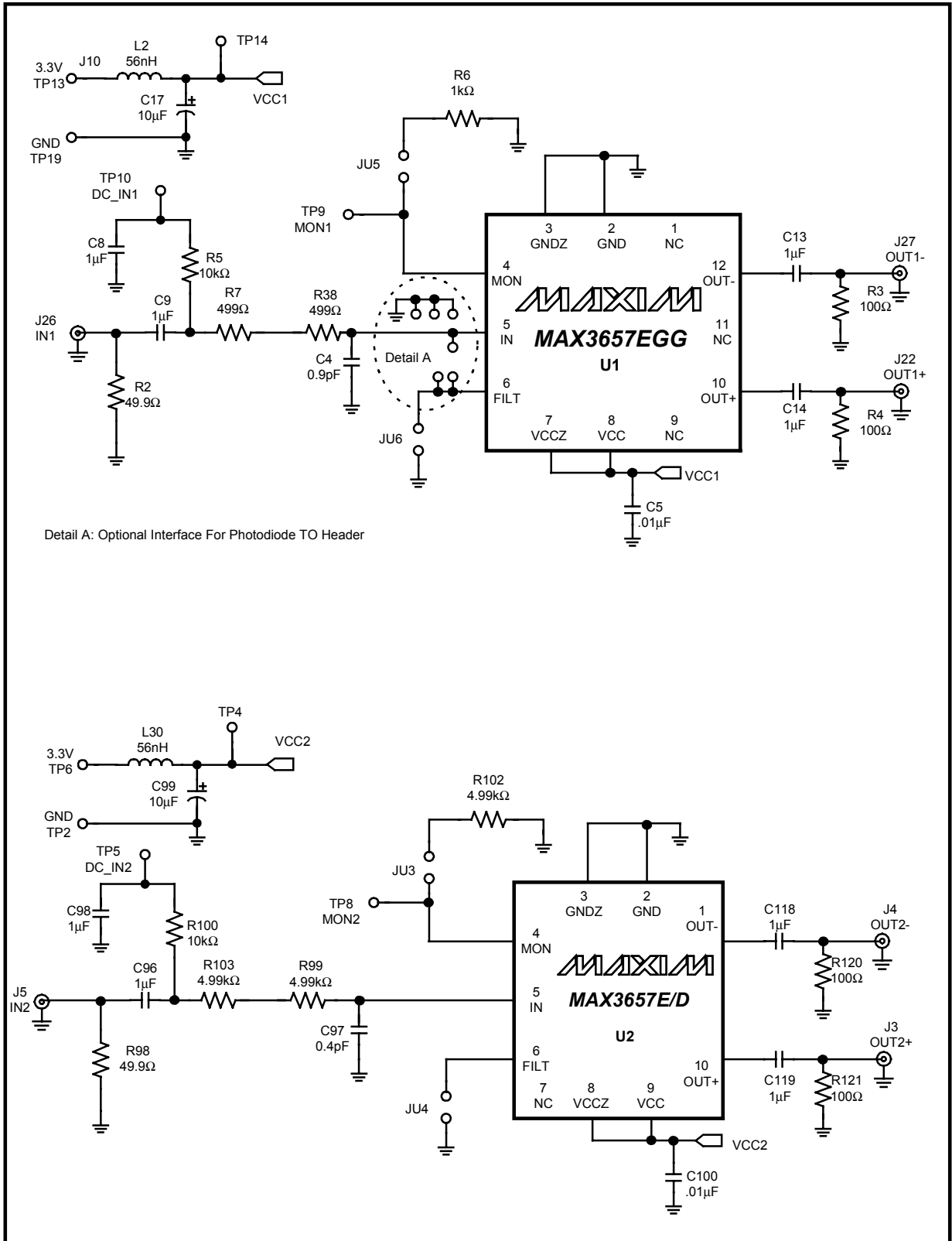

Figure 1. MAX3657 EV Kit Schematic Diagram - QFN and Die-Attach Sections

# MAX3657 Evaluation Kit

Evaluate: MAX3657

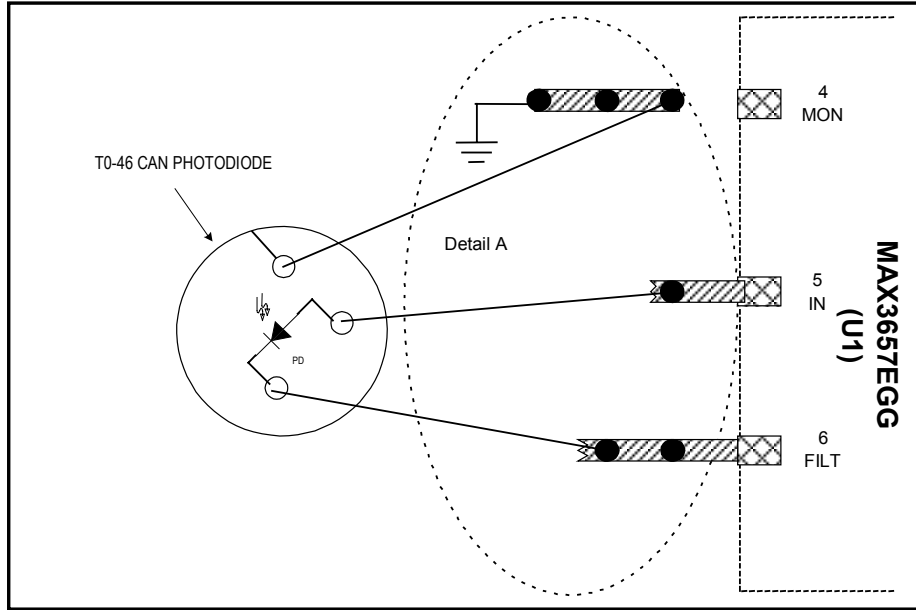

Figure 2. Photodiode Interface (QFN Section).

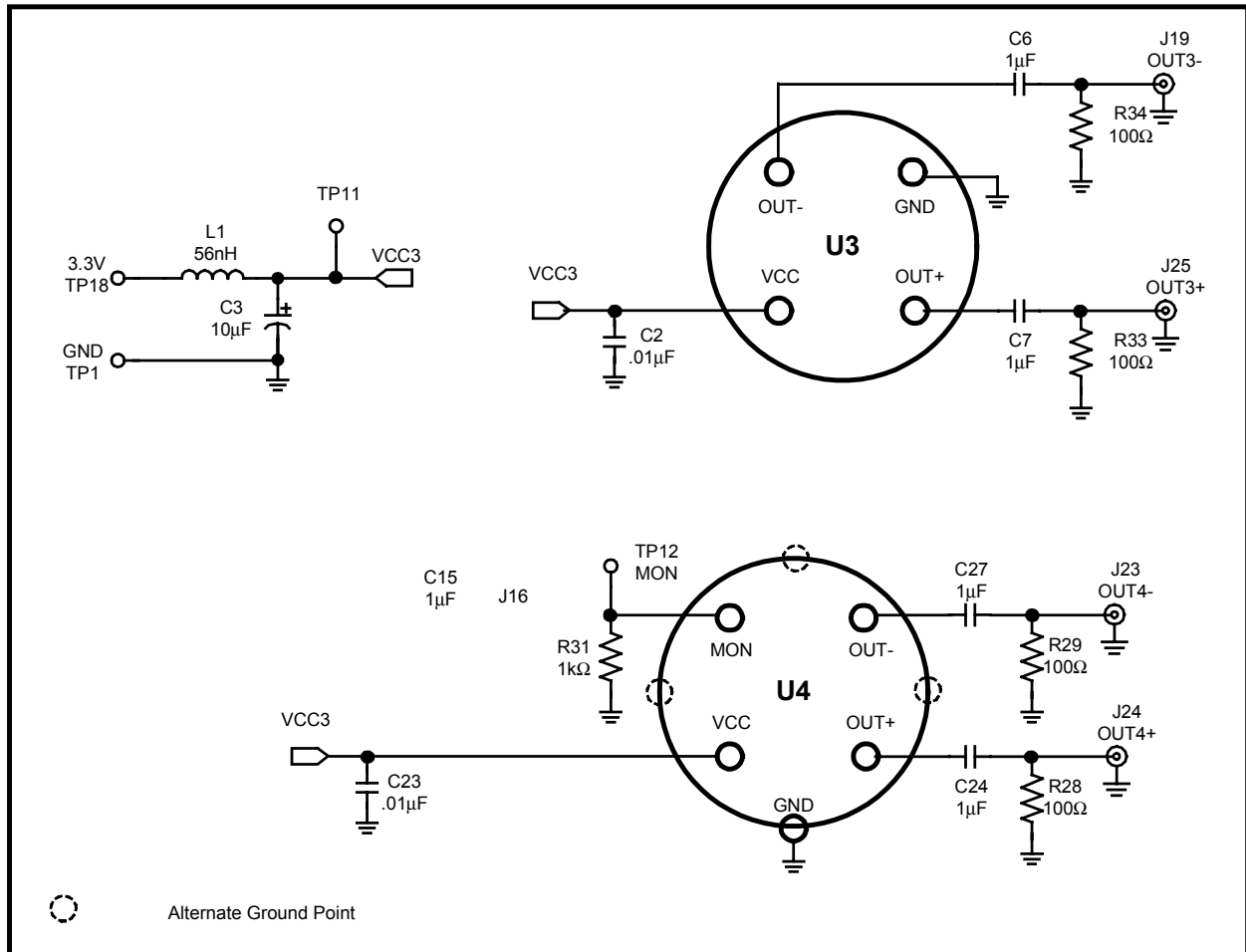

Figure 3. MAX3657 EV Kit Schematic Diagram - Optional TO-Header Interface (Assembly Required).

# MAX3657 Evaluation Kit

Evaluate: MAX3657

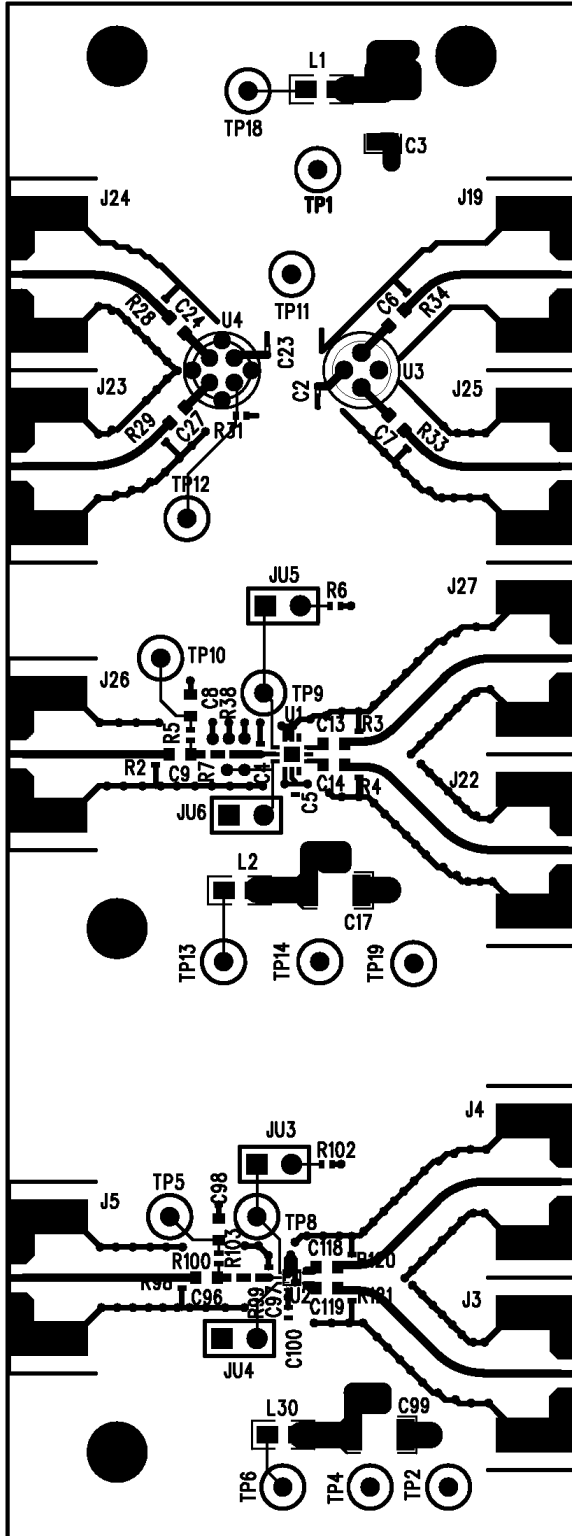

Figure 4. MAX3657 EV Kit Component Placement Guide - Component Side

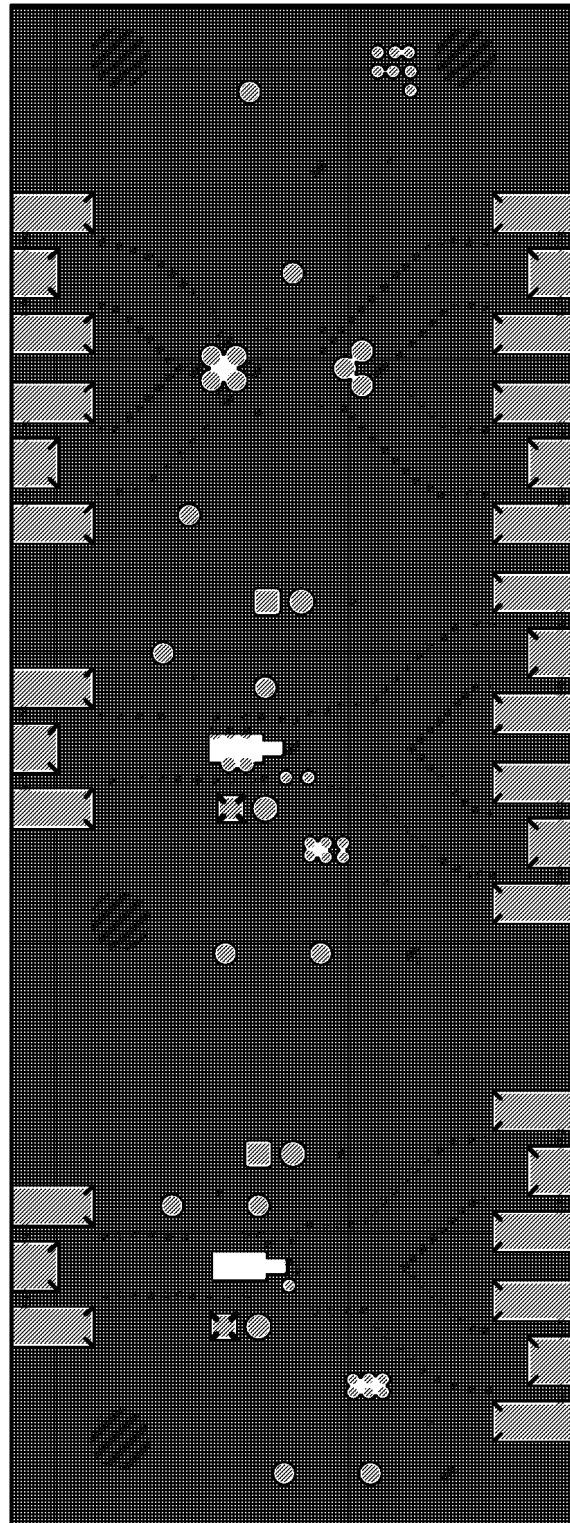

Figure 5. MAX3657EV Kit PC Board Layout - Solder Side

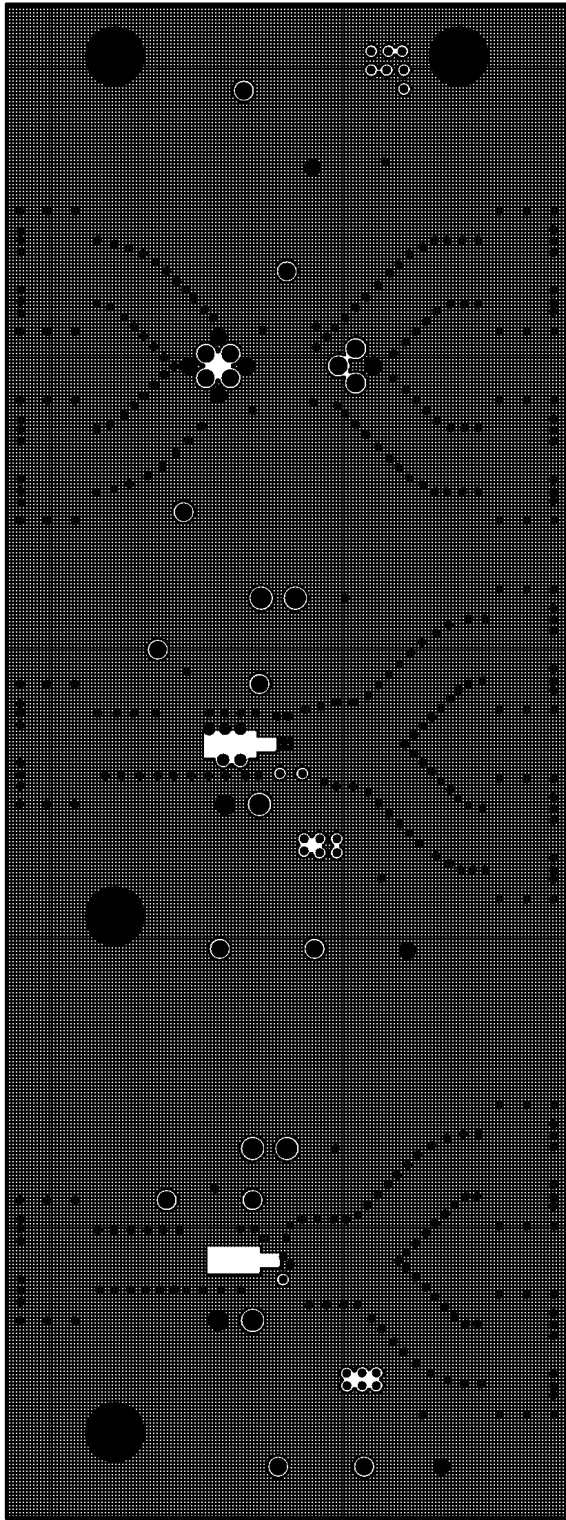

Figure 6. MAX3657EV Kit PC Board Layout - Ground Plane

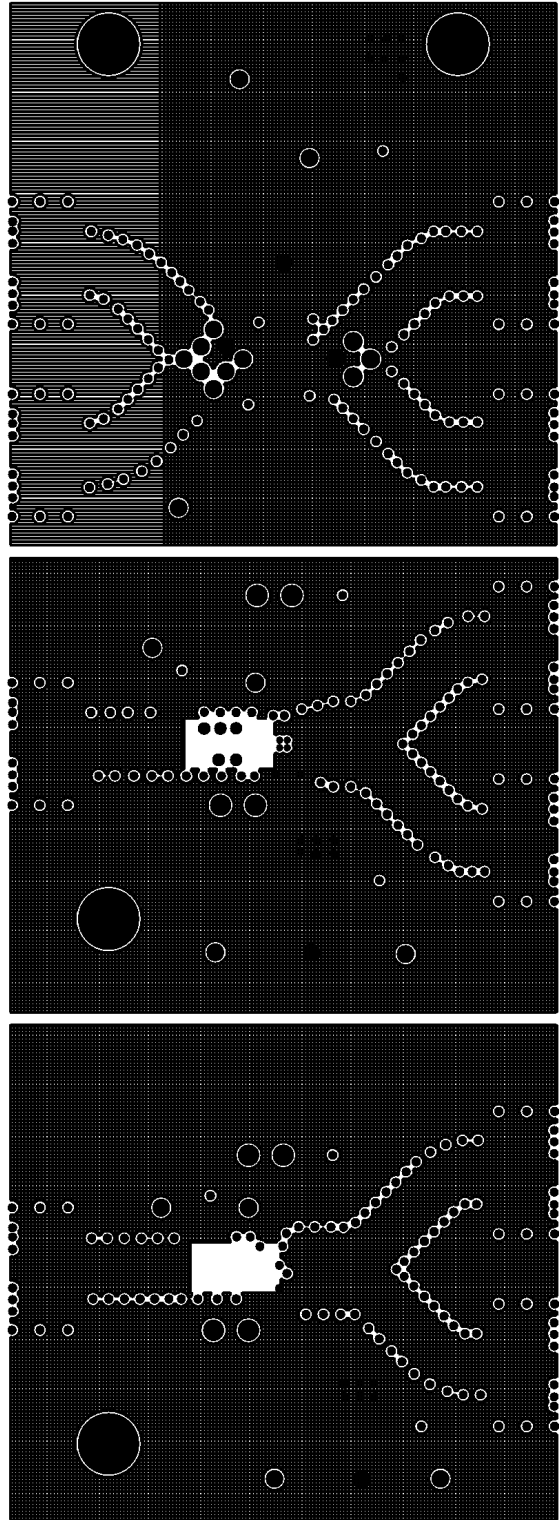

Figure 7. MAX3657EV Kit PC Board Layout - Power Plane

Maxim cannot assume responsibility for use of any circuitry other than circuitry entirely embodied in a Maxim product. No circuit patent licenses are implied. Maxim reserves the right to change the circuitry and specifications without notice at any time.