

HD81831Y10/Y20(DSP-I)

Digital Signal Processor Image

The HD81831 (DSP- I) is a signal chip processor with stored program capability designed for digital signal processing including image processing.

The DSP- I can perform multiply and accumulate at a ultra-high speed. Moreover, it achieves high throughput by performing data operation and data transfer simultaneously.

The DSP- I incorporates two-dimensional addressing operation functions and powerful bit processing functions for image a processing, realizing high speed repetitive operations and division. Since its internal memory space consists only of RAM, programs can be changed depending on the application, thus enabling the DSP- I to perform various types of signal processing. Moreover, the DSP- I has a large external data memory space to 16M words, and host MPU can be interfaced to multiple DSP- I s in a multiprocessor system to enhance throughput.

The DSP- I can be widely used for various application requiring high speed and high accuracy operations such as image processing, communications and control systems.

Hardware Features

- 32-bit high speed fixed point ALU and 16-bit high speed fixed point multiplier incorporated
- Built-in high speed bit processing unit (BPU)
- High speed data processing
- High throughput owing to pipeline operations and horizontal microinstructions
- Two-hierarchical instruction structure allowing data operations and data transfer to occur simultaneously
- High speed data transfer achieved with double buffer method using multi-bank large capacity internal data RAM
- Three types of addressing operation units incorporated
- N-bit barrel rotator incorporated
- Wait function for low speed external data memory
- Built-in large capacity memory
 - instruction RAM:
 - microinstruction: 1024 words × 48 bits
 - picoinstruction: 64 words × 16 bits
 - data RAM: 512 words × 4 pages × 16 bits

- Large external data memory space of 16M words × 16 bits
- External instruction memory expandable up to 15k words × 48 bits
- 8/16 bit microcomputer interface
- Multiprocessor function
 - Control command communication between the host MPU and multiple DSP- I s using processor numbers
 - Task communication for cascade connection
- Internal register contents which can be changed forcibly by control commands from the host MPU
- DMA operation with the host MPU or other external devices
- High speed transfer of a large amount of data or program without DMAC(PIO transfer)
- 4 level subroutine nesting
- +5 V single power supply
- Package : 135-pin PGA

Software Features

- Each operation instruction executed in a single machine cycle.
- Two-hierarchical instruction format: microinstructions and picoinstructions
- Data read, addition/subtraction, multiplication, data write, internal data RAM addressing operations, data transfer to external data memory, external data memory addressing operations and repeat counter decrementation, all executed by a single program step
- Two-dimensional addressing operation executed by a single program step
- Continuous access operation over a large external data memory space of 16M words
- Three types of repeat functions
 - n-step high speed repeat instruction loop instruction
 - loop due to jump instruction
- Program transfer mode (PIO mode) allowing high speed transfer between a host MPU and internal data RAM and instruction RAM without DMAC
- Various types of high speed bit processing performed in word units (such as word synthesizing, word matching, run-length measurement)

HD81831Y10/Y20

Product line-up

Product name	Machine cycle	Input clock (CLK1)
HD81831Y10	100ns (10MIPS)	10 MHz
HD81831Y20	50ns (20MIPS)	20 MHz

Bench Marks

		Execution Time	
		HD81831Y10	HD81831Y20
General Operations (fixed point)	32 bit ALU operations (ADD, SHIFT, etc.)	100ns	50ns
	Multiply and accumulate	100ns	50ns
	16×16 → 32 bit multiply	100ns	50ns
	Double length multiply (32×32 → 64 bits)	5.6μs	2.8μs
	Double length multiply (32×16 → 29 bits)	0.9μs	0.45μs
	Double length multiply (32×16 → 32 bits)	1.7μs	0.85μs
	Double length multiply (32×30 → 32 bits)	2.5μs	1.25μs
	Divide (32/16 bits) (quotient only)	2μs	1μs
	Divide (32/16 bits) (both quotient and remainder produced)	3.7μs	1.85μs
	Square root	8.3μs	4.15μs
	Trigonometric functions (SIN, COS)	5.4μs	2.7μs
	Matrix operations (16×16)	0.62μs	0.31μs
General Operations (floating point)	Multiply (28 bit mantissa field, 16 bit exponent field)	8.7μs	4.35μs
	Add/subtract (28 bit mantissa field, 16 bit exponent field)	6.6μs	3.3μs
	Divide (28 bit mantissa field, 16 bit exponent field)	5.7μs	2.85μs
	Square (28 bit mantissa field, 16 bit exponent field)	8.8μs	4.4μs
Filter Operations (fixed point)	256 point complex FFT	1.30ms	0.65ms
	512 point complex FFT	2.90ms	1.45ms
	1024 point complex FFT	7.66ms	3.83ms
	Transversal filter (Filter degree; 2)	7.9μs	3.95ms
	Bi-cut filter (single stage)	3.0μs	1.5μs
Image Processing Operations	Affine transform (black and white, 2 levels, using external data memory)	1600ns/PIXEL	800ns/PIXEL
	Spatial filter (3×3 pixels, filter, using external data memory)	3.0μs/PIXEL	1.5μs/PIXEL
	Histogram conversion (512×512 pixels, using external data memory)	315ms	157.5ms

Note: Refer to the "HD81831 Application Note" document for details on the above benchmarks.

Pin Arrangement

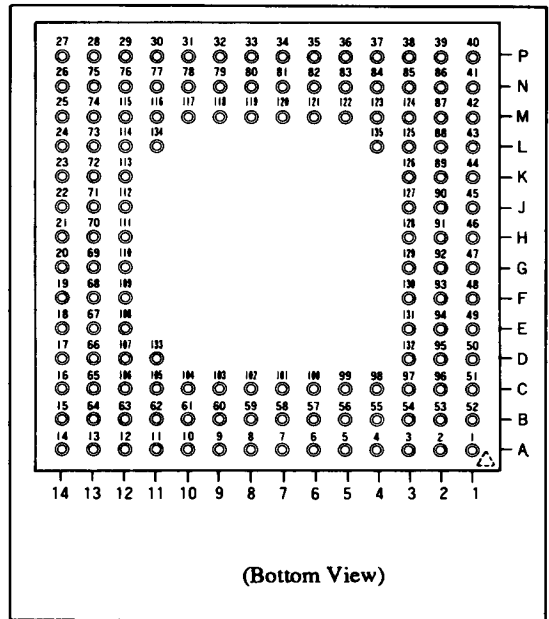
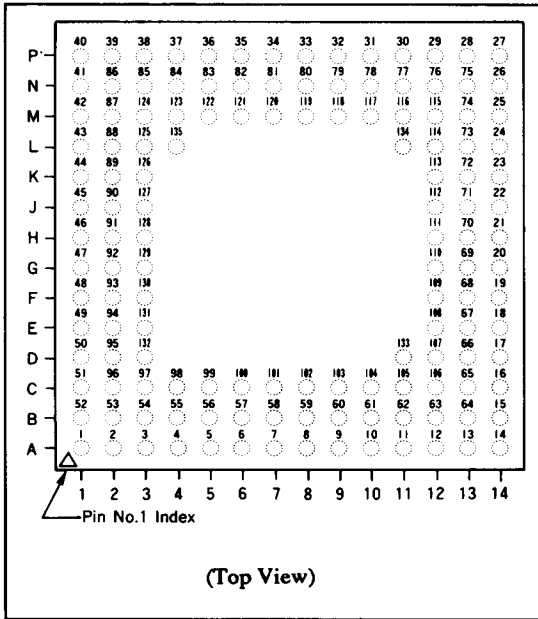

HD81831Y10/Y20

Block Diagram

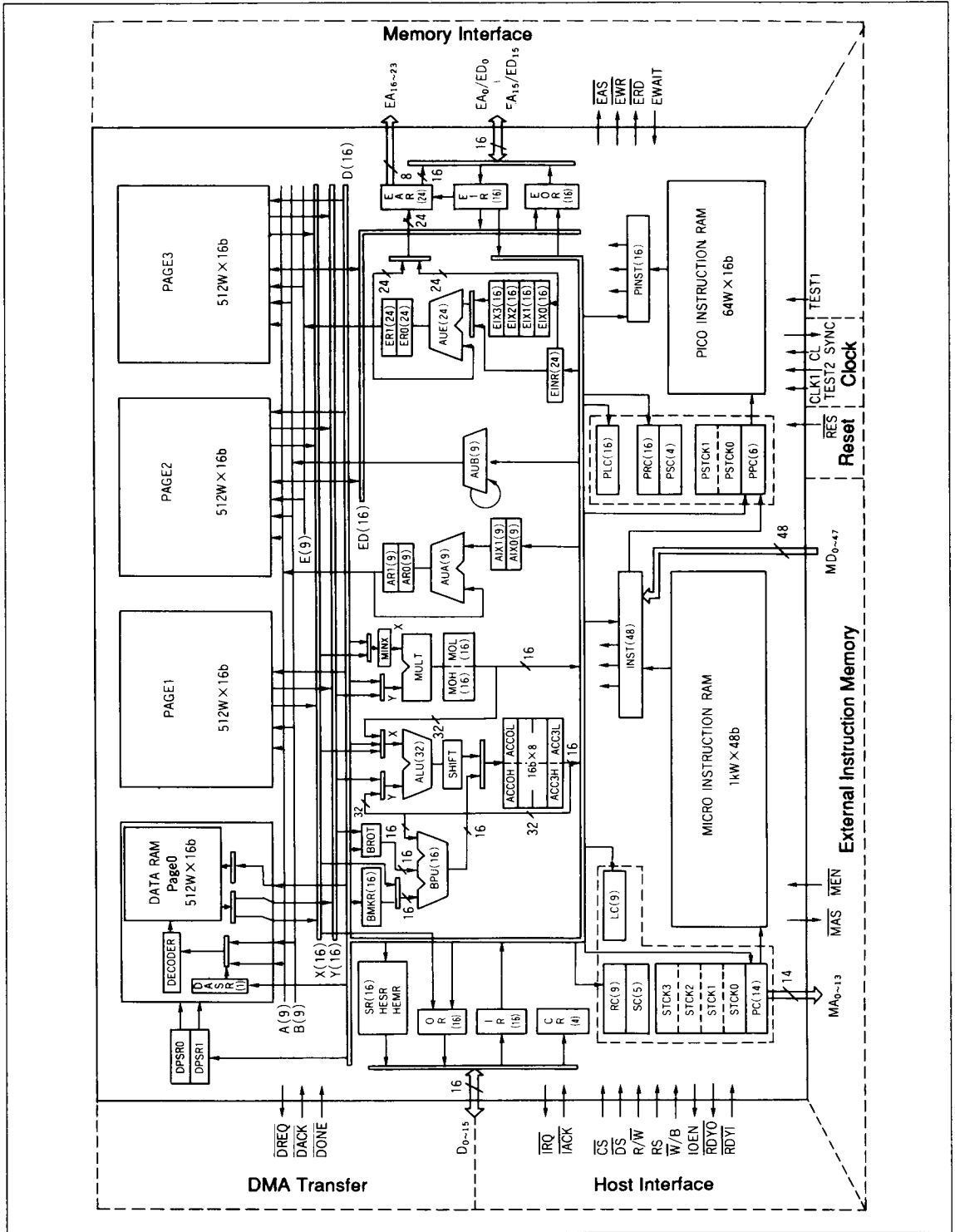

**Architecture
Data Operation and Data Transfer
(Executed in Parallel)**

The DSP- I provides microinstructions controlling data operations and picoinstructions controlling data transfer between internal data RAM and external data memory. These two instruction sets can operate independent of each other. In addition, the DSP- I includes 4 pages of internal data RAM,

which can be used as a data cache by assigning each page to be controlled by microinstruction or picoinstruction. Therefore, using these functions, the DSP- I can perform data operations in parallel with data transfer between internal data RAM and external data memory. This enables high data throughput.

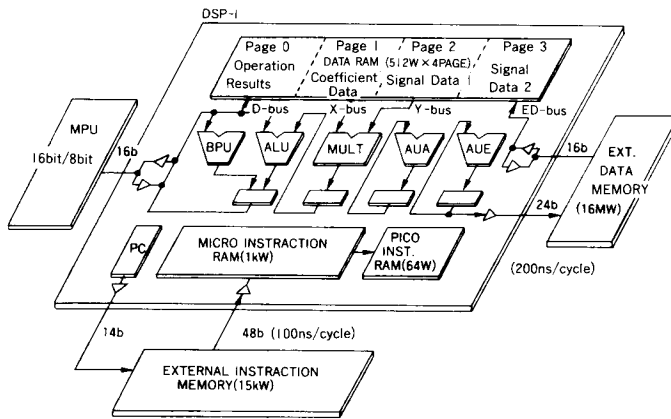

(a) The DSP- I performs data operations using signal data 1.

Simultaneously, it transfers signal data 2 required for the next data operation from external data memory into page 3.

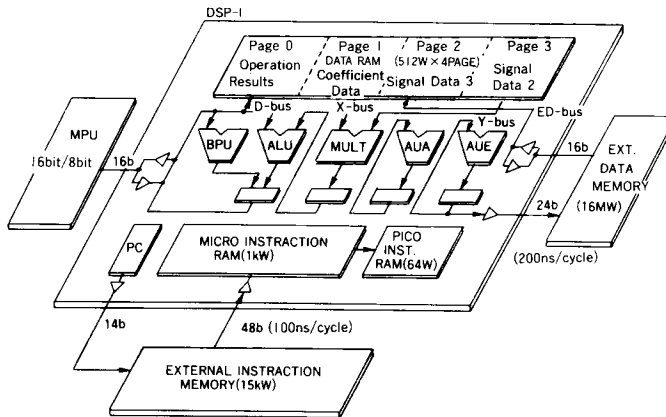

(b) After completing data operations (a), the DSP- I interchanges page 2 and page 3. It then executes data operations using signal data 2 of page 3. Simultaneously, it trans-

fers signal data 3 from external data memory to page 2 preparatory to the next data operation.

* The External Expansion Memory Access cycle shown is for the HD81831Y20. The memory access cycle for the HD81831Y10 is twice.

Figure 1. Example of Double Buffer Operation

Double-Hierarchical Format Instructions

Operations of microinstructions and dcoinstructions are shown in figure 2. A picoinstruction is activated by a microinstruction, after which it operates independent of microinstruction. A picoinstruction is activated by describing the address of the to picoin-

structions to be activated in the microinstruction. To synchronize the operations of microinstructions and picoinstructions, microinstruction execution must be halted by the WAIT instruction to wait for the picoinstruction to stop.

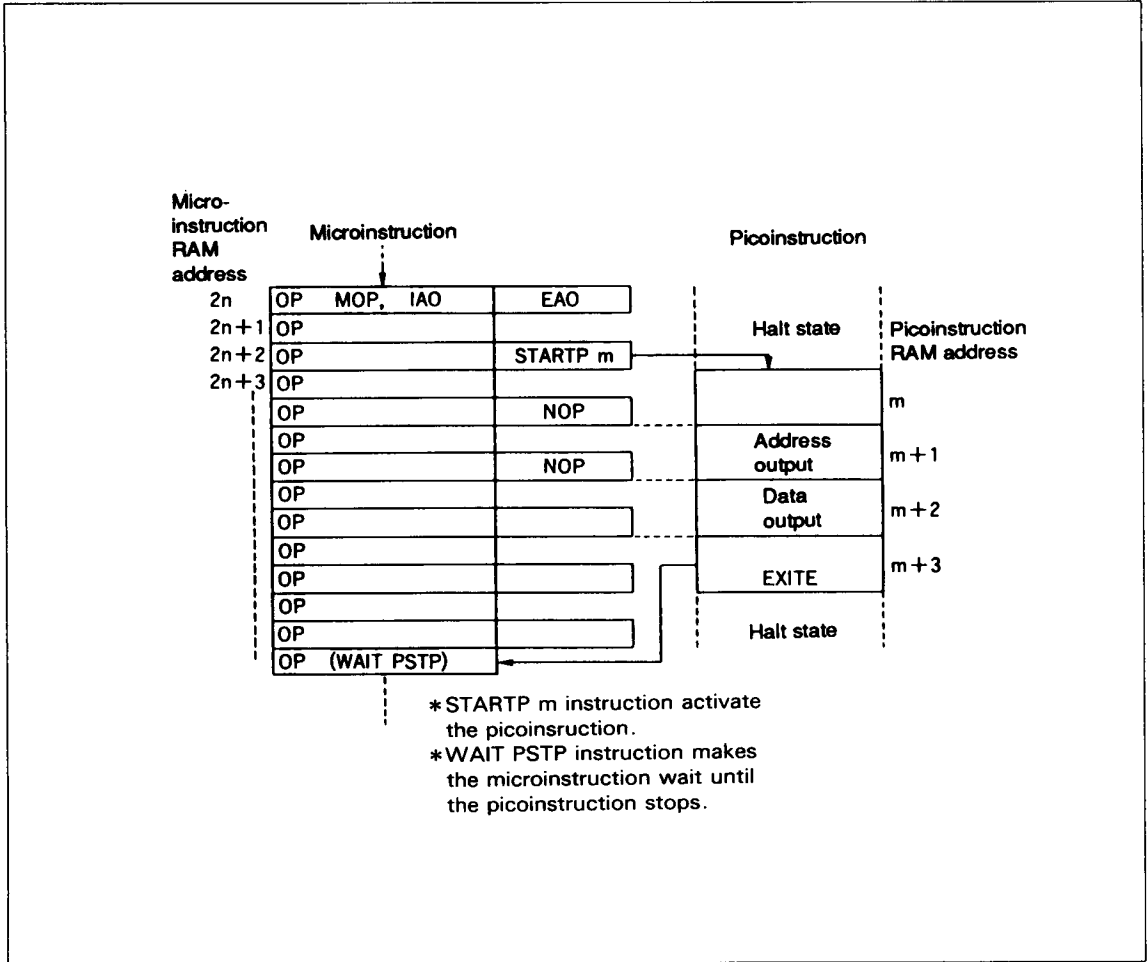

Figure 2. Microinstructions and Picoinstructions Operation

Multiprocessor System

The host MPU communicates with the DSP- I using control commands.

The DSP- I has a 12 bit processor number expressed two-dimensionally (DSP- I identification number). Thus it can be used in a multiprocessor system consisting of up to 64×64 DSP- I s (See figure 3). In a multiprocessor system, all DSP- I s are connected to the same system bus. Each DSP- I uses its processor number to determine whether or not the host MPU control commands are given to

itself.

Processor number of zero is used for global communication. As figure 3 shows, both X number and Y number are specified when a single DSP- I communicates with the host MPU, but either X number or Y number is zero when the host MPU communicates with all DSP- I s along a row (X direction) or column (Y direction). In addition, when both X and Y numbers are zero, all DSP- I s communicate with the host MPU.

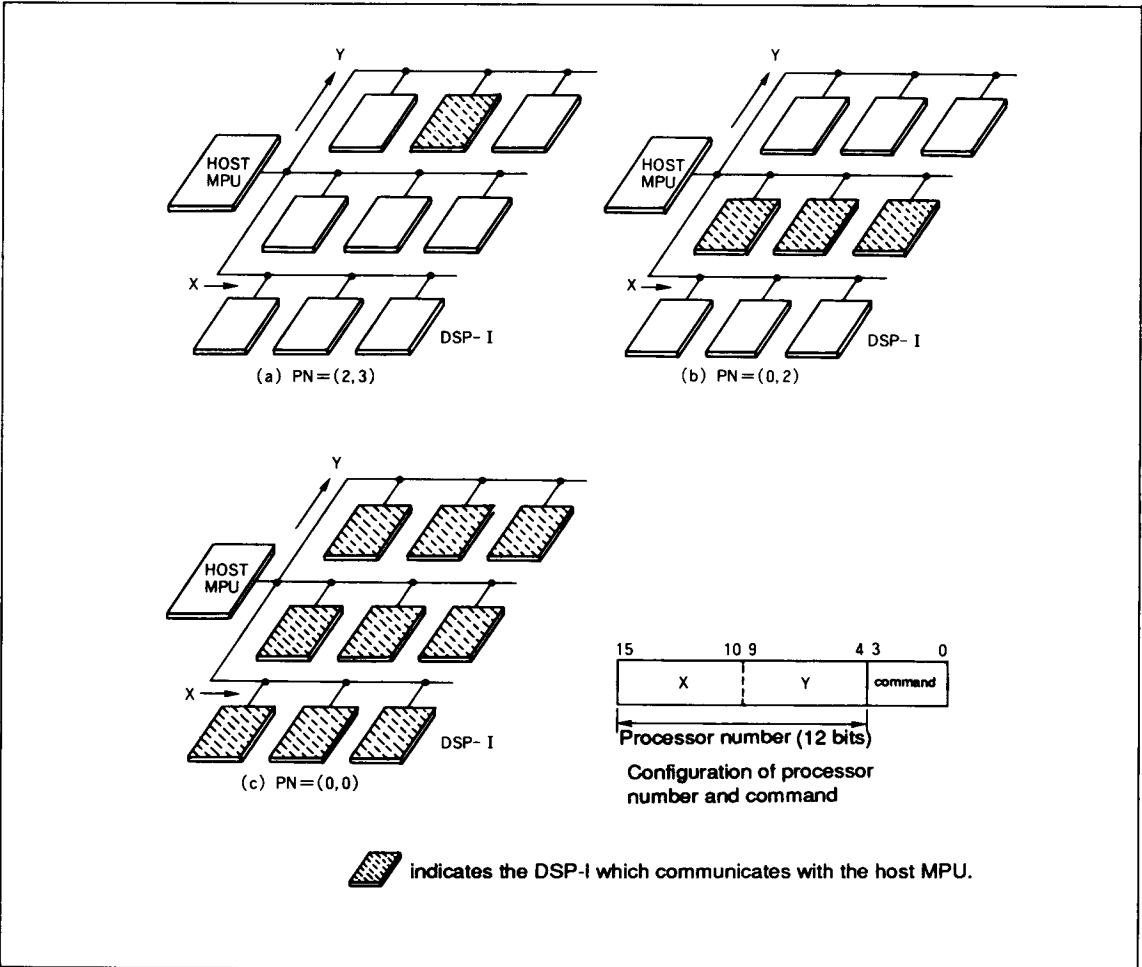

Figure 3. Example of Multiprocessor System

Instruction Execution Cycle Time and Memory Access Time

The DSP- I provides two types of instruction sets: microinstructions and picoinstructions, and incorporates instruction memory for each instruction set. The DSP- I is characterized by

ultra-high speed operations, but it can use low-speed external memory. Table 1 summarizes instruction execution cycle time memory access times.

Table 1. Instruction Execution Cycle Time (When basic clock cycle time is 50 ns)

Instruction memory	Microinstruction execution	Data operation and internal data RAM addressing execution time	External data memory access time	
			Microinstruction (EAO field)	Picoinstruction
Internal	50ns	50ns	200ns	200ns
External	100ns	100ns	400ns	

* Values for the HD81830Y10 are twice of those listed in the above table.

Bit processign unit (BPU)

The DSP- I has a high-performance bit processing unit (BPU) which realizes a high-speed image processig. Figure 4 shows block diagram of the bit processing unit. Table 2 lists examples of processing.

This bit processing unit consists of the following:

Bit rotator (BROT)

The bit rotator (BROT) rotates left 16-bit data (bits 0-15) from Y bus or D bus. It also provides bit rotation and bit reverse in one instruction cycle. The BROT instruction or the rotate register (BRTC, 4 bits) specifies the rotate value as an immediate value. The BRTC is a counter register which is incremented while shifting data. The rotated data is stored in the accumulator or used in an operation with the other operand.

Mask data generator (MSKG)

The mask data generator (MSKG) is used to generate mask data depending on rotate value N.

These mask data realizes high-speed performance : synthesis of two word data and bit data substitution.

Mask data register (BMKR)

This register stores an optional mask data in addition to the mask data generated by the MSKG. The MBKR is set by the MOV instruction.

Logic operation block

This block performs a logic operation (AND, OR, XOR) between BROT data and accumulator data (or the result and AND of mask data and ACC), which realizes data synthesis.

Priority Encoder (PE)

This block performs priority encoding data via BROT, priority encoding selects the first bit location to be set to 1 from the MSB side. The PE realizes data normalization and run length measurement.

PE input data	PE output data
0000000000000000	\$0000
1000000000000000	\$0001
0100000000000000	\$0002
⋮	⋮
0000000000000001	\$0010

Bit counter

This block is used to count the number of bits set to 1 in word data via BROT, which realizes pattern matching between two word data.

Table 2. Examples of Bit Processings

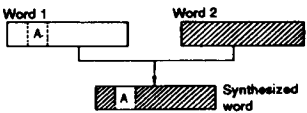
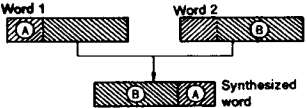
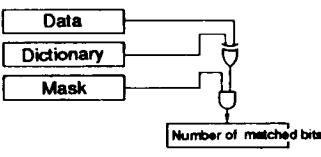
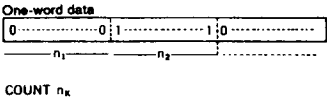
Processing	Number of Steps		Description
	DSP- I	HD61810	
Bit substitution	1	3	
Two-word synthesis	2	17	
Pattern matching with masking	2	51	
Run length measurement	7	64	

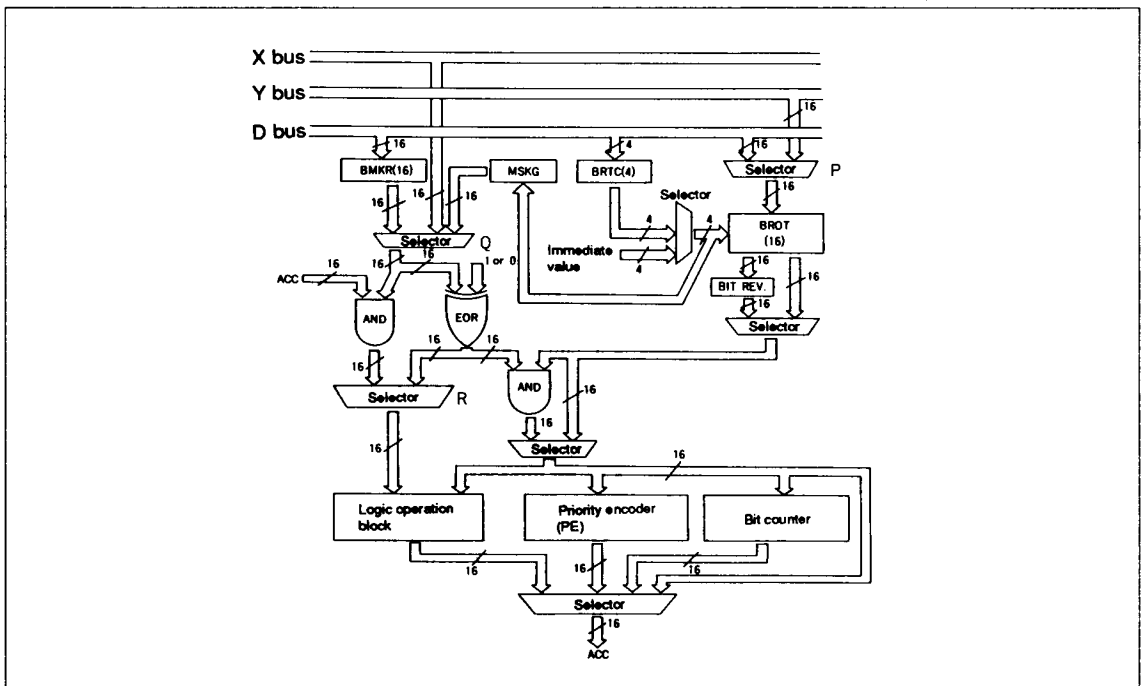

Figure 4. BPU (Bit Processing Unit) Configuration