



## ST3DV520A

### High bandwidth switch with 20- to 10-bit MUX/DEMUX

#### Features

- Low  $R_{ON}$ : 4.0  $\Omega$  typical
- $V_{CC}$  operating range: 3.0 to 3.6 V
- Enhanced ESD protection: > 8 kV (contact) and 15 kV (HBM)
- Channel on capacitance: 9.5 pF typical
- Switching time speed: 9 ns
- Near to zero propagation delay: 250 ps
- Very low crosstalk: -45 dB at 250 MHz
- Bit-to-bit skew: 200 ps
- > 600 MHz -3 dB typical bandwidth (or data frequency)
- Package: QFN56

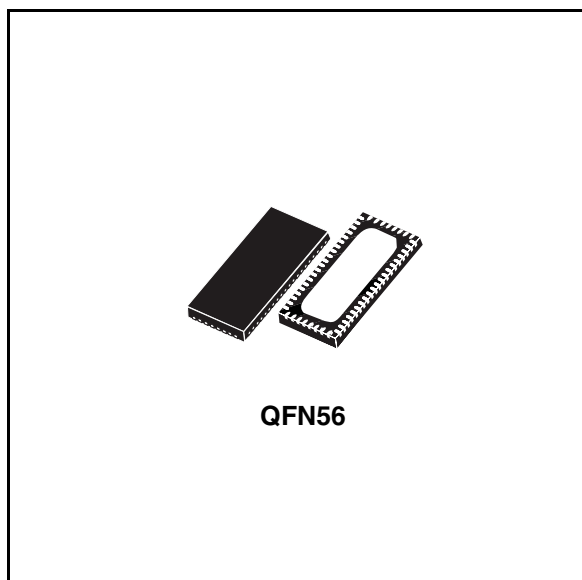

#### Description

The ST3DV520A is a 20- to 10-bit multiplexer/demultiplexer low  $R_{ON}$  and high bandwidth bidirectional switch suitable for analog video applications.

The signal from each input is multiplexed into one of two selected outputs while the unselected switch goes to Hi-Z status. The device is designed for very low crosstalk, low bit-to-bit skew and low I/O capacitance.

The ST3DV520A supports high definition (HD) video switching standards and is also suitable for general purpose switching that requires high signal integrity.

www.DataSheet4U.com

**Table 1. Device summary**

Order code	Package	Packing
ST3DV520AQTR	QFN56	Tape and reel

## Contents

<b>1</b>	<b>Pin description</b> .....	<b>3</b>
<b>2</b>	<b>Maximum ratings</b> .....	<b>6</b>
	2.1 Recommended operating conditions .....	6
<b>3</b>	<b>Electrical characteristics</b> .....	<b>7</b>
<b>4</b>	<b>Package mechanical data</b> .....	<b>16</b>
<b>5</b>	<b>Revision history</b> .....	<b>20</b>

# 1 Pin description

Figure 1. Pin connection (top through view)

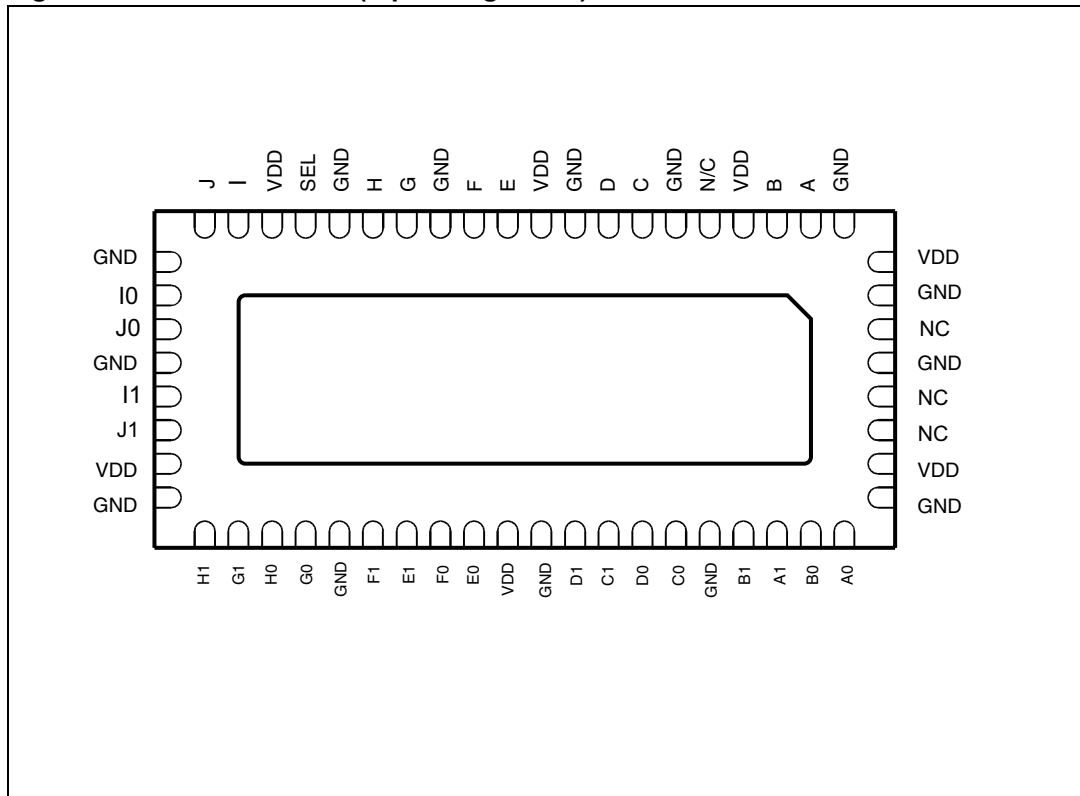
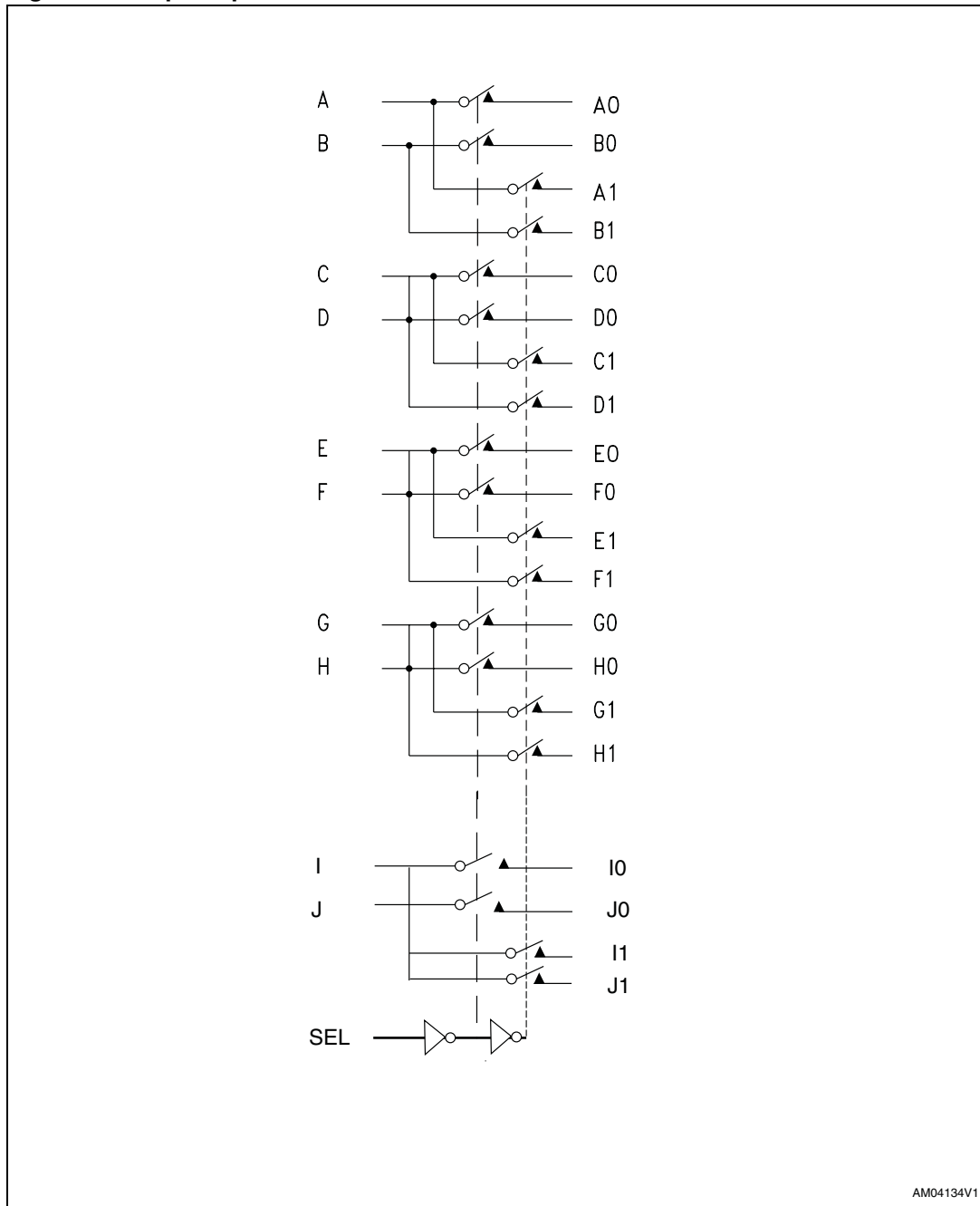

Table 2. Pin description

Pin	Symbol	Name and function
2, 3, 7, 8, 11, 12, 14, 15, 19, 20	A, B, C, D, E, F, G, H, I, J	10-bit bus
22, 23, 48, 47, 43, 42, 37, 36, 32, 31	A0, B0, C0, D0, E0, F0, G0, H0, I0, J0	10-bit multiplexed to bus 0
25, 26, 46, 45, 41, 40, 35, 34, 30, 29	A1, B1, C1, D1, E1, F1, G1, H1, I1, J1	10-bit multiplexed to bus 1
5, 51, 52, 54	N/C	Not connected
17	SEL	Bus and LED switch selection
4, 10, 18, 27, 38, 50, 56	V <sub>DD</sub>	Supply voltage
1, 6, 9, 13, 16, 21, 24, 28, 33, 39, 44, 49, 53, 55	GND	Ground

Figure 2. Input equivalent circuit



www.DataSheet4U.com

AM04134V1

Table 3. Switch function table

SEL	Function
L	10-bit bus to 10-bit multiplexed bus 0
H	10-bit bus to 10-bit multiplexed bus 1

## 2 Maximum ratings

Stressing the device above the rating listed in the “absolute maximum ratings” table may cause permanent damage to the device. These are stress ratings only and operation of the device at these or any other conditions above those indicated in the operating sections of this specification is not implied. Exposure to absolute maximum rating conditions for extended periods may affect device reliability.

**Table 4. Absolute maximum ratings**

Symbol	Parameter	Value	Unit
$V_{CC}$	Supply voltage to ground	-0.5 to 4.6	V
$V_{IO}$	DC input output voltage	-0.5 to 4.6	V
$V_{IC}$	DC control input voltage	-0.5 to 4.6	V
$I_O$	DC output current <sup>(1)</sup>	120	mA
$P_D$	Power dissipation	0.5	W
$T_{stg}$	Storage temperature	-65 to 150	°C
$T_L$	Lead temperature (10 sec)	300	°C

1. If  $V_{IO} \times I_O$  does not exceed the maximum limit of  $P_D$ .

### 2.1 Recommended operating conditions

**Table 5. Recommended operating conditions**

Symbol	Parameter	Value			Unit
		Min	Typ	Max	
$V_{CC}$	Supply voltage to ground	3	–	3.6	V
$V_{IC}$	DC control input voltage (SEL)	0	–	5	V
$V_{IO}$	DC input/output voltage	0	–	$V_{CC}$	V
$T_A$	Operating temperature	-40	–	85	°C

### 3 Electrical characteristics

**Table 6. DC electrical characteristics ( $V_{CC} = 3.3\text{ V} \pm 10\%$ )**

Symbol	Parameter	Test condition	Value			Unit
			-40 to 85 °C			
			Min	Typ	Max	
$V_{IH}$	Voltage input high (SEL)	High level guaranteed	2	–	–	V
$V_{IL}$	Voltage input low (SEL)	Low level guaranteed	-0.5	–	0.8	V
$V_{IK}$	Clamp diode voltage (SEL)	$V_{CC} = 3.6\text{ V}$ $I_{IN} = -18\text{ mA}$	–	-0.8	-1.2	V
$I_{IH}$	Input high current (SEL)	$V_{CC} = 3.6\text{ V}$ $V_{IN} = V_{CC}$	–	–	$\pm 5$	$\mu\text{A}$
$I_{IL}$	Input low current (SEL)	$V_{CC} = 3.6\text{ V}$ $V_{IN} = \text{GND}$	–	–	$\pm 5$	$\mu\text{A}$
$I_{OFF(SW)}^{(1)}$	Leakage current through the switch common terminals (A to J)	$V_{CC} = 3.6\text{ V}$ A to J = $V_{CC}$ LED1 to LED3 = $V_{CC}$ A0 to J0 = 0 V A1 to J1 = floating SEL = $V_{CC}$	–	–	$\pm 1$	$\mu\text{A}$
$I_{OFF(SEL)}$	SEL pin leakage current	$V_{CC} = 0\text{ V}$ SEL = 0 to 3.6 V	–	–	$\pm 1$	$\mu\text{A}$
$R_{ON}$	Switch ON resistance <sup>(2)</sup>	$V_{CC} = 3.0\text{ V}$ $V_{IN} = 1.5\text{ to }V_{CC}$ $I_{IN} = -40\text{ mA}$	–	4.0	6.5	$\Omega$
$R_{FLAT}$	ON resistance flatness <sup>(2)(3)</sup>	$V_{CC} = 3.0\text{ V}$ $V_{IN}$ at 1.5 and $V_{CC}$ $I_{IN} = -40\text{ mA}$	–	0.5	–	$\Omega$
$\Delta R_{ON}$	ON resistance match between channel $\Delta R_{ON} = R_{ONMAX} - R_{ONMIN}$ <sup>(2)(4)</sup>	$V_{CC} = 3.0\text{ V}$ $V_{IN} = 1.5\text{ to }V_{CC}$ $I_{IN} = -40\text{ mA}$	–	0.4	1	$\Omega$

1. Refer to [Figure 4: Test circuit for leakage current \(IOFF\) on page 9](#)
2. Measured by voltage drop between channels at indicated current through the switch. ON resistance is determined by the lower of the voltages.
3. Flatness is defined as the difference between the  $R_{ONMAX}$  and  $R_{ONMIN}$  of ON resistance over the specified range.
4.  $\Delta R_{ON}$  measured at same  $V_{CC}$ , temperature and voltage level.

**Table 7. Capacitance ( $T_A = 25\text{ °C}$ ,  $f = 1\text{ MHz}$ )**

Symbol	Parameter	Test condition	Value			Unit
			Min	Typ	Max	
$C_{IN}$	SEL pin input capacitance <sup>(1)</sup>	DC = 0.25 V AC = 0.5 V <sub>PP</sub> f = 1 MHz	–	2	3	pF
$C_{OFF}$	Switch off capacitance <sup>(2)</sup>	DC = 0.25 V AC = 0.5 V <sub>PP</sub> f = 1 MHz	–	4	5	pF
$C_{ON}$	Switch on capacitance <sup>(3)</sup>	DC = 0.25 V AC = 0.5 V <sub>PP</sub> f = 1 MHz	–	9.5	11	pF

1. Refer to [Figure 5 on page 10](#)
2. Refer to [Figure 6 on page 10](#)
3. Refer to [Figure 7 on page 11](#)

**Table 8. Power supply characteristics**

Symbol	Parameter	Test condition	Value			Unit
			-40 to 85 °C			
			Min	Typ	Max	
$I_{CC}$	Quiescent power supply	$V_{CC} = 3.6\text{ V}$ , $V_{IN} = V_{CC}$ or GND	–	150	500	μA

**Table 9. Dynamic electrical characteristics ( $V_{CC} = 3.3\text{ V} \pm 10\%$ )**

Symbol	Parameter	Test condition	Value			Unit
			-40 to 85 °C			
			Min	Typ	Max	
$X_{talk}$	Crosstalk <sup>(1)</sup>	$R_L = 100\ \Omega$ f = 250 MHz	–	-45	–	dB
$O_{IRR}$	Off isolation <sup>(2)</sup>	$R_L = 100\ \Omega$ f = 250 MHz	–	-37	–	dB
BW	-3 dB bandwidth <sup>(3)</sup>	$R_L = 100\ \Omega$ $0 < V_{IN} \leq 3.6\text{ V}$	–	600	–	MHz

1. Refer to [Figure 9 on page 12](#)
2. Refer to [Figure 10 on page 13](#)
3. Refer to [Figure 8 on page 11](#)

## Electrical characteristics

## ST3DV520A

**Table 10. Switching characteristics ( $T_A = 25\text{ }^\circ\text{C}$ ,  $V_{CC} = 3.3\text{ V} \pm 10\%$ )**

Symbol	Parameter	Test condition	Value			Unit
			Min	Typ	Max	
$t_{PD}$	Propagation delay	$V_{CC} = 3\text{ to }3.6\text{ V}$	–	0.25	–	ns
$t_{PZH}$ , $t_{PZL}$	Line enable time, SE to x to x0 or x to x1	$V_{CC} = 3\text{ to }3.6\text{ V}$	0.5	6.5	15	ns
$t_{PHZ}$ , $t_{PLZ}$	Line disable time, SE to x to x0 or x to x1	$V_{CC} = 3\text{ to }3.6\text{ V}$	0.5	6.5	8.5	ns
$t_{SK(O)}$	Output skew between center port to any other port	$V_{CC} = 3\text{ to }3.6\text{ V}$	–	0.1	0.2	ns
$t_{SK(P)}$	Skew between opposite transition of the same output ( $t_{PHL}$ , $t_{PLH}$ )	$V_{CC} = 3\text{ to }3.6\text{ V}$	–	0.1	0.2	ns

**Table 11. ESD performance**

Symbol	Test condition	Value			Unit
		Min	Typ	Max	
ESD	Contact discharge <sup>(1)</sup> IEC61000-4-2	–	$\pm 8$	–	kV
	Human body model (MIL-STD-883)	–	$\pm 15$	–	kV

1. Refer to [Figure 3: Diagram for suggested VDD decoupling on page 9.](#)



Figure 3. Diagram for suggested  $V_{DD}$  decoupling

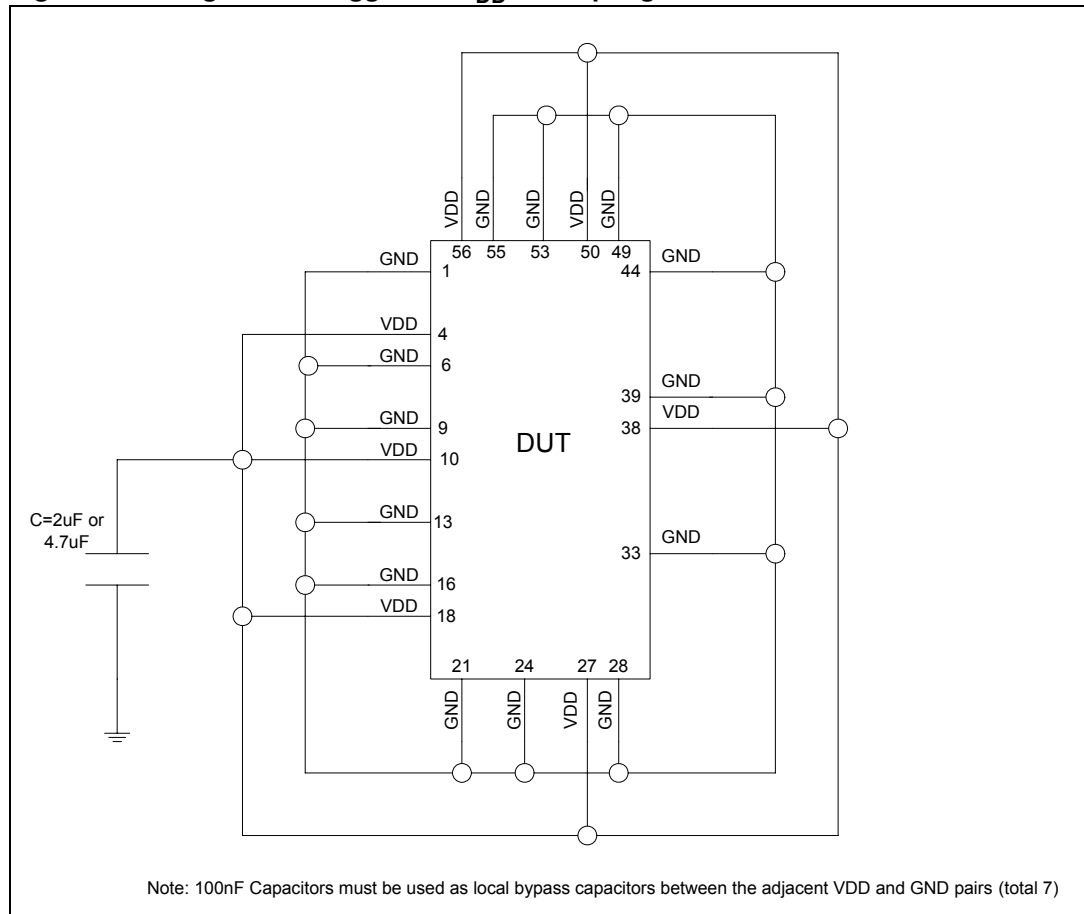

1. Applicable for system level ESD test

Figure 4. Test circuit for leakage current ( $I_{OFF}$ )

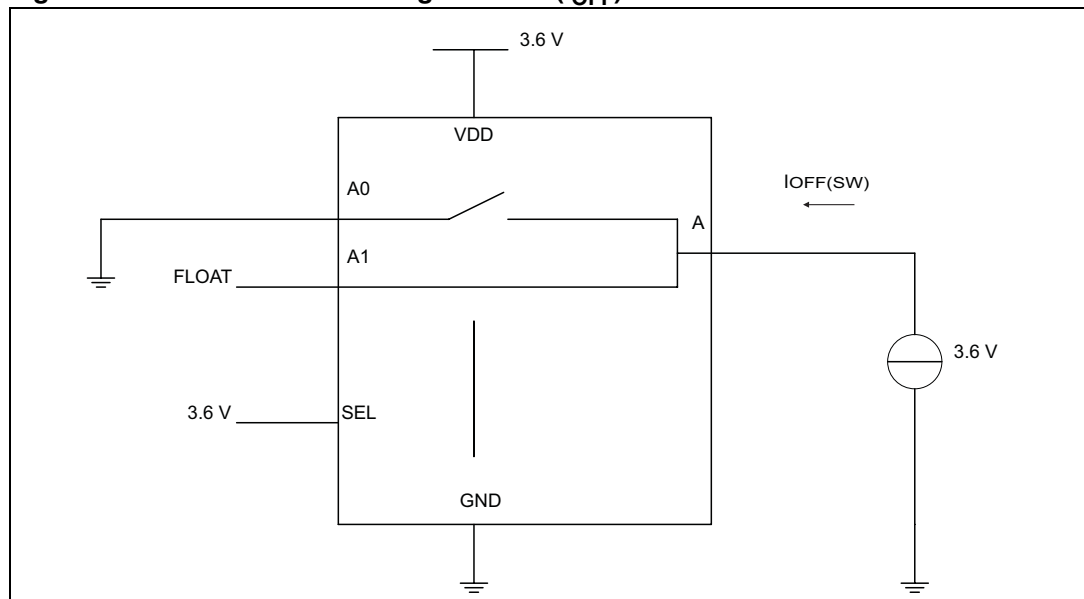

Figure 5. Test circuit for SEL pin input capacitance ( $C_{IN}$ )Figure 6. Test circuit for switch off capacitance ( $C_{OFF}$ )

Figure 7. Test circuit for switch on capacitance ( $C_{ON}$ )

Figure 8. Test circuit for bandwidth measurement (BW)

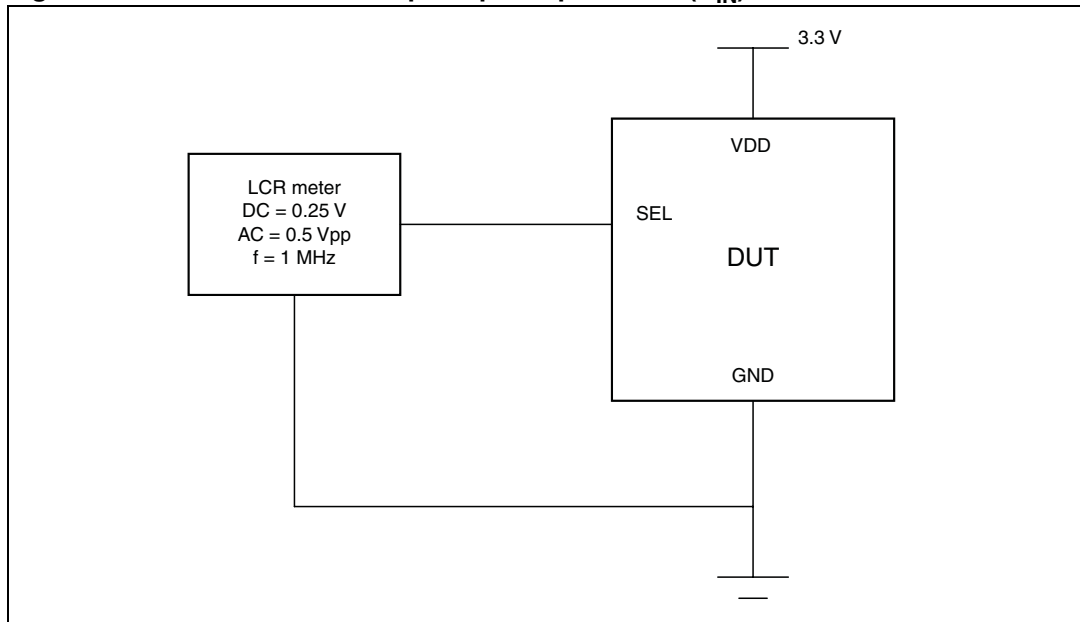
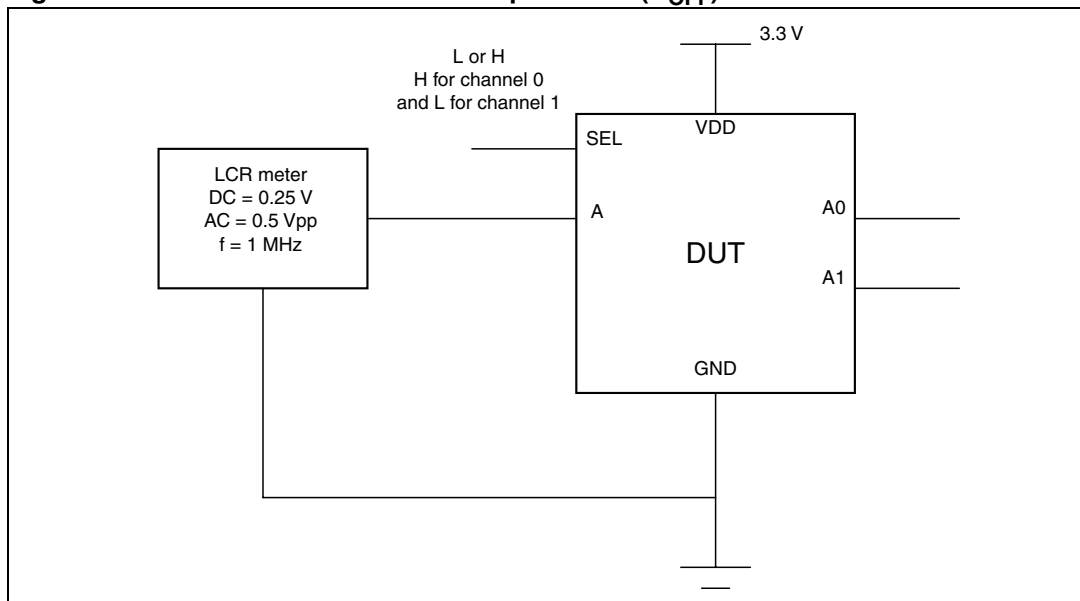

Frequency response is measured at the output of the ON channel. For example, when  $V_{SEL} = 0$  and A is the input, the output is measured at A0. All unused analog I/O ports are left open.

HP8753ES setup:

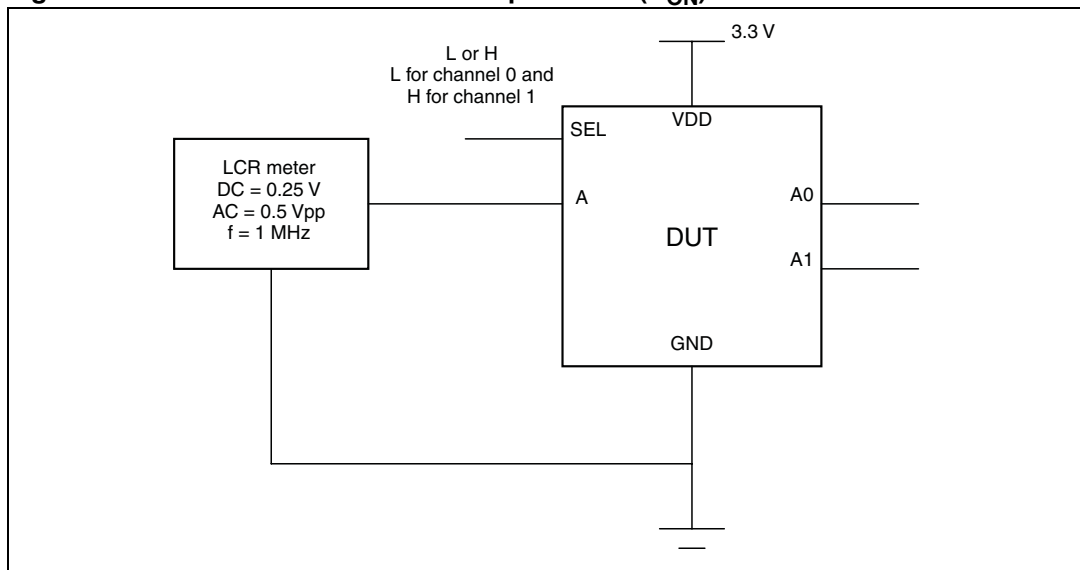
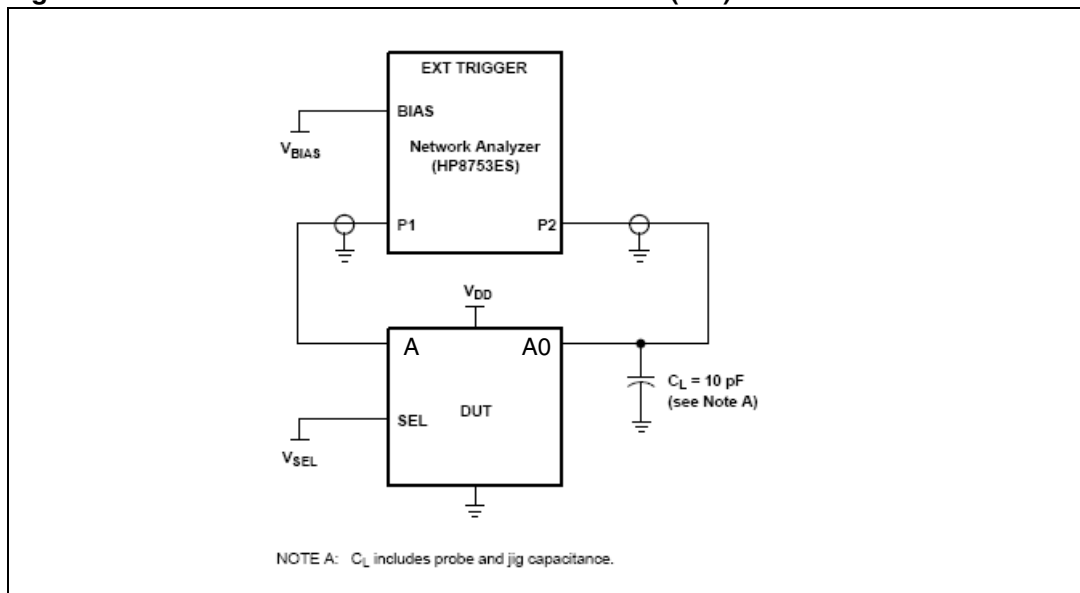
Average = 4

$R_{BW} = 3$  kHz

$V_{BIAS} = 0.35$  V

ST = 2 s

P1 = 0 dBm

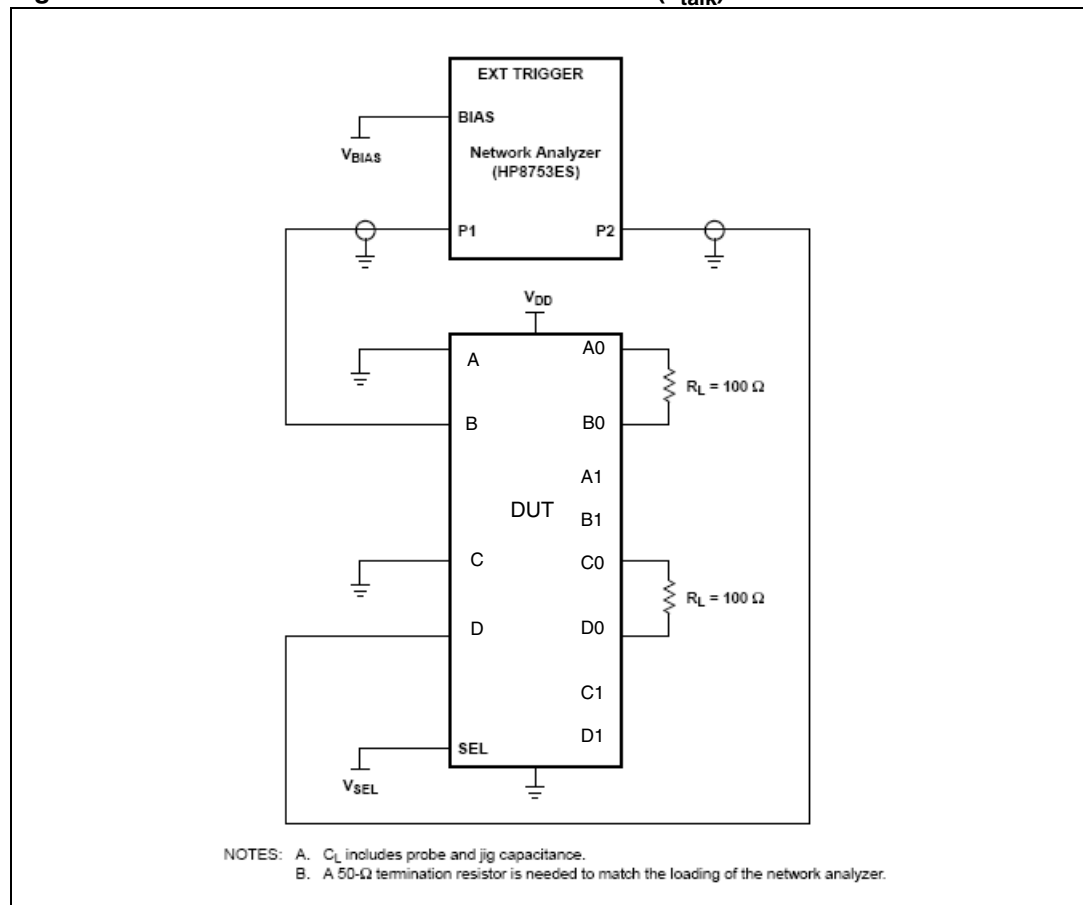
Figure 9. Test circuit for crosstalk measurement ( $x_{\text{talk}}$ )

Crosstalk is measured at the output of the non-adjacent ON channel. For example, when  $V_{\text{SEL}} = 0$ , and B is the input, the output is measured at D. All unused analog input ports are connected to GND and output ports are left open.

HP8753ES setup:

Average = 4

$R_{\text{BW}} = 3 \text{ kHz}$

$V_{\text{BIAS}} = 0.35 \text{ V}$

ST = 2 s

P1 = 0 dBm

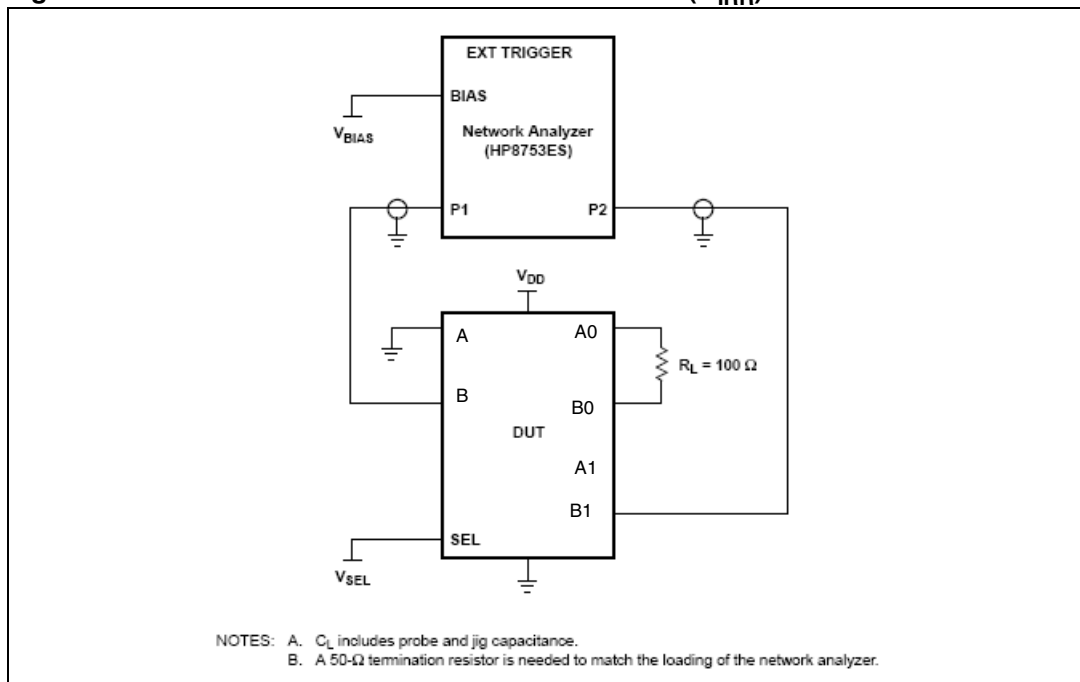
Figure 10. Test circuit for off isolation measurement ( $O_{IRR}$ )

Off isolation is measured at the output of the OFF channel. For example, when  $V_{SEL}=0$ , and B is the input, the output is measured at B1. All unused analog input ports are connected to GND and output ports are left open.

HP8753ES setup:

Average = 4

$R_{BW} = 3$  kHz

$V_{BIAS} = 0.35$  V

ST = 2 s

P1 = 0 dBm



Figure 12. Mechanical data for QFN56 (11 x 5 mm) - pitch 0.5 mm

Symbol	Millimeters		
	Min	Typ	Max
A	0.70	0.75	0.80
A1	–	–	0.05
A3		0.20	–
b	0.20	0.25	0.30
D	10.90	11.00	11.10
D2	8.30	8.40	8.50
D3	–	9.50	–
E	4.90	5.00	5.10
E2	2.30	2.40	2.50
E3	–	3.50	–
e	–	0.50	–
L	0.30	0.40	0.50

Figure 13. Footprint recommendation for QFN56 (11 x 5 mm) - pitch 0.5 mm

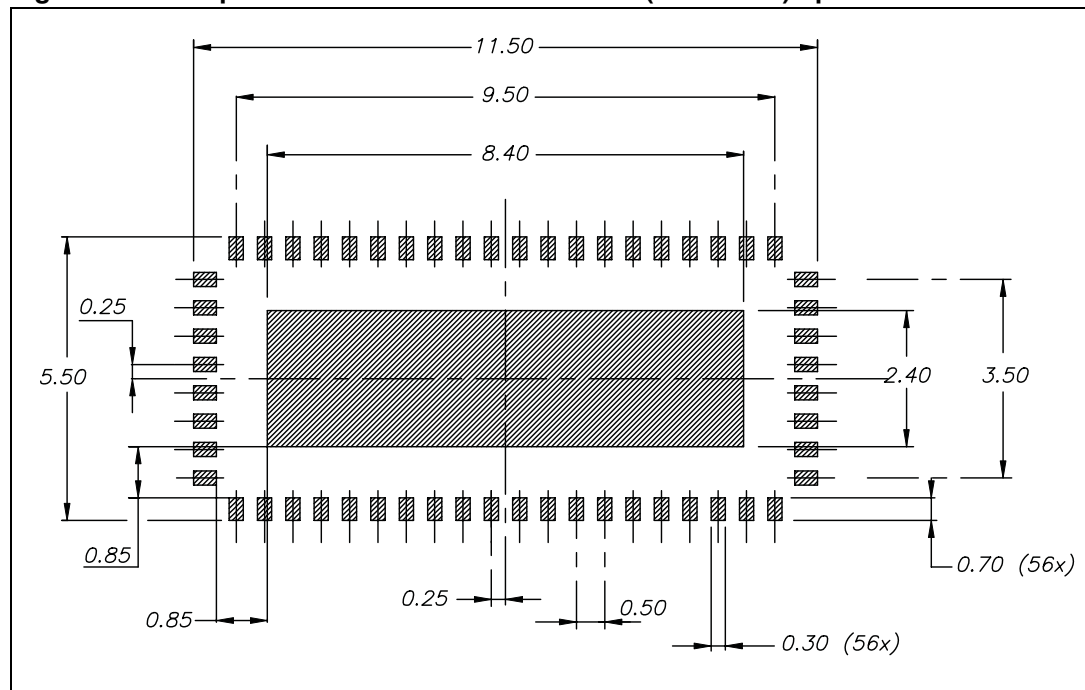

Figure 14. Carrier tape information for QFN56 (11 x 5 mm) - pitch 0.5 mm

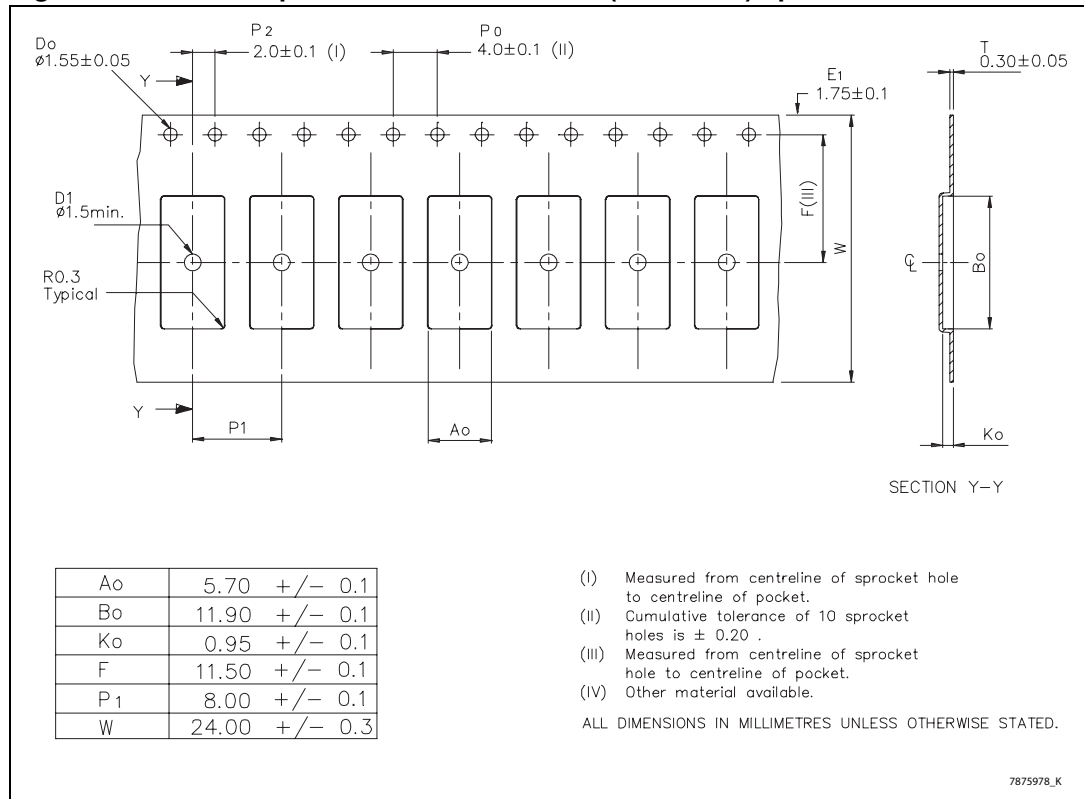
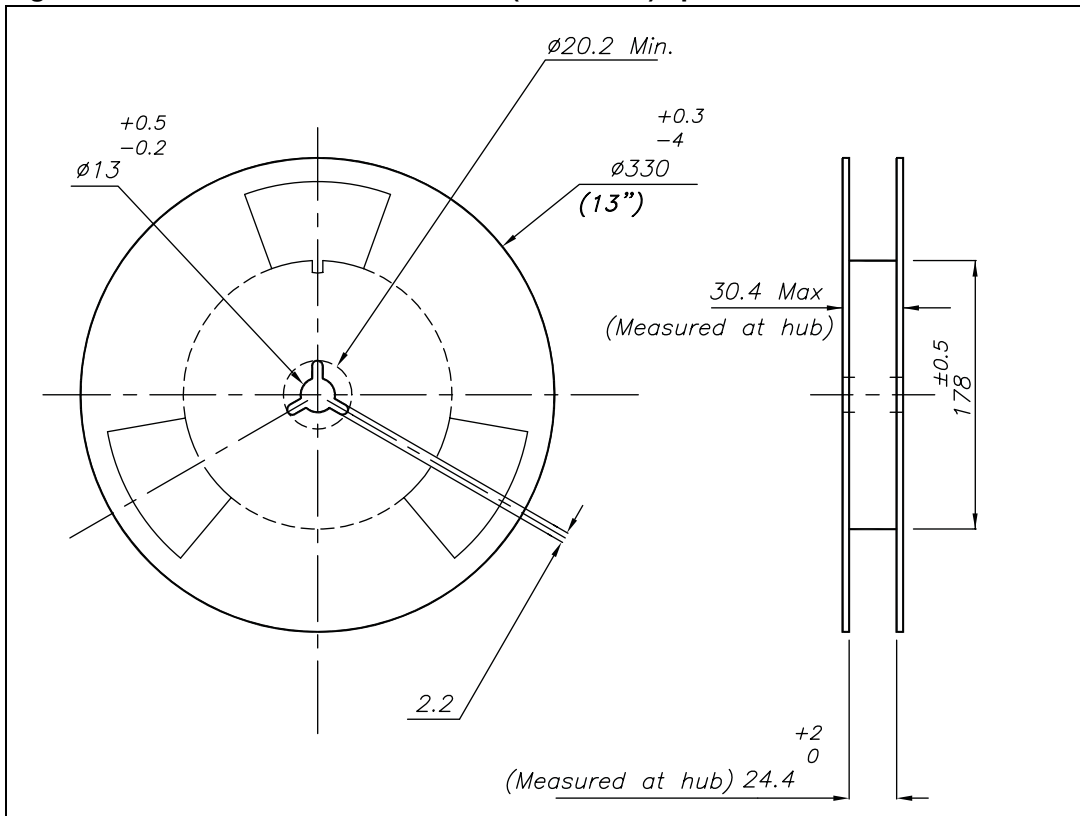



Figure 15. Reel information for QFN56 (11 x 5 mm) - pitch 0.5 mm



## 5 Revision history

**Table 12. Document revision history**

Date	Revision	Changes
11-Dec-2009	1	Initial release.

**ST3DV520A**

---

**Please Read Carefully:**

Information in this document is provided solely in connection with ST products. STMicroelectronics NV and its subsidiaries ("ST") reserve the right to make changes, corrections, modifications or improvements, to this document, and the products and services described herein at any time, without notice.

All ST products are sold pursuant to ST's terms and conditions of sale.

Purchasers are solely responsible for the choice, selection and use of the ST products and services described herein, and ST assumes no liability whatsoever relating to the choice, selection or use of the ST products and services described herein.

No license, express or implied, by estoppel or otherwise, to any intellectual property rights is granted under this document. If any part of this document refers to any third party products or services it shall not be deemed a license grant by ST for the use of such third party products or services, or any intellectual property contained therein or considered as a warranty covering the use in any manner whatsoever of such third party products or services or any intellectual property contained therein.

**UNLESS OTHERWISE SET FORTH IN ST'S TERMS AND CONDITIONS OF SALE ST DISCLAIMS ANY EXPRESS OR IMPLIED WARRANTY WITH RESPECT TO THE USE AND/OR SALE OF ST PRODUCTS INCLUDING WITHOUT LIMITATION IMPLIED WARRANTIES OF MERCHANTABILITY, FITNESS FOR A PARTICULAR PURPOSE (AND THEIR EQUIVALENTS UNDER THE LAWS OF ANY JURISDICTION), OR INFRINGEMENT OF ANY PATENT, COPYRIGHT OR OTHER INTELLECTUAL PROPERTY RIGHT.**

**UNLESS EXPRESSLY APPROVED IN WRITING BY AN AUTHORIZED ST REPRESENTATIVE, ST PRODUCTS ARE NOT RECOMMENDED, AUTHORIZED OR WARRANTED FOR USE IN MILITARY, AIR CRAFT, SPACE, LIFE SAVING, OR LIFE SUSTAINING APPLICATIONS, NOR IN PRODUCTS OR SYSTEMS WHERE FAILURE OR MALFUNCTION MAY RESULT IN PERSONAL INJURY, DEATH, OR SEVERE PROPERTY OR ENVIRONMENTAL DAMAGE. ST PRODUCTS WHICH ARE NOT SPECIFIED AS "AUTOMOTIVE GRADE" MAY ONLY BE USED IN AUTOMOTIVE APPLICATIONS AT USER'S OWN RISK.**

www.DataSheet4U.com

Resale of ST products with provisions different from the statements and/or technical features set forth in this document shall immediately void any warranty granted by ST for the ST product or service described herein and shall not create or extend in any manner whatsoever, any liability of ST.

ST and the ST logo are trademarks or registered trademarks of ST in various countries.

Information in this document supersedes and replaces all information previously supplied.

The ST logo is a registered trademark of STMicroelectronics. All other names are the property of their respective owners.

© 2009 STMicroelectronics - All rights reserved

STMicroelectronics group of companies

Australia - Belgium - Brazil - Canada - China - Czech Republic - Finland - France - Germany - Hong Kong - India - Israel - Italy - Japan - Malaysia - Malta - Morocco - Philippines - Singapore - Spain - Sweden - Switzerland - United Kingdom - United States of America

[www.st.com](http://www.st.com)

