



SANYO Semiconductors DATA SHEET

LC8740C8A LC8740B2A LC874096A

CMOS IC
Internal 128K/112K/96K-byte ROM (Program ROM/CGROM),
2048-byte RAM, 1024-byte CGROM,
and 704×10-bit CRT Display RAM

8-bit 1-chip Microcontroller

Overview

The SANYO LC8740C8A/B2A/96A is a closed caption TV controlling 8-bit microcomputer that, centered around a CPU running at a minimum bus cycle time of 71ns, integrates on a single chip a number of hardware features such as 128K/112K/96K-byte ROM (size-variable program ROM and CGROM), 2048-byte RAM, 1024-byte CGRAM, 704×10-bit CRT display RAM, sophisticated 16-bit timers/counters (may be divided into 8-bit timers), a 16-bit timer/counter (may be divided into 8-bit timers/counters, two 8-bit timers with a prescaler, a base timer serving as a time-of-day clock, a high-speed clock counter, a synchronous SIO interface (with automatic block transmission/reception capabilities), two channels of asynchronous/synchronous SIO interface (bus mode selectable), a UART interface (full duplex), an 8-bit 8-channel AD converter, one 14-bit PWM channel, three 8-bit PWM channels, a closed caption data slicer, closed caption compatible OSD, a system clock frequency divider and ROM correction function.

Features

■Internal ROM

- 131072 × 8 bits (LC8740C8A)
- 114688 × 8 bits (LC8740B2A)
- 98304 × 8 bits (LC874096A)

■Internal RAM

- General-purpose RAM: 2K bytes
- Character generator RAM: 1K bytes
- CRT display RAM: 704 × 10 bits
- ROM correction RAM: 256 bytes

■Minimum Bus Cycle Time

- 71ns (14.1MHz)

Note: The bus cycle time here refers to the ROM read speed.

■Minimum Instruction Cycle Time

- 212ns (14.1MHz)

■ Any and all SANYO Semiconductor products described or contained herein do not have specifications that can handle applications that require extremely high levels of reliability, such as life-support systems, aircraft's control systems, or other applications whose failure can be reasonably expected to result in serious physical and/or material damage. Consult with your SANYO Semiconductor representative nearest you before using any SANYO Semiconductor products described or contained herein in such applications.

■ SANYO Semiconductor assumes no responsibility for equipment failures that result from using products at values that exceed, even momentarily, rated values (such as maximum ratings, operating condition ranges, or other parameters) listed in products specifications of any and all SANYO Semiconductor products described or contained herein.

SANYO Semiconductor Co., Ltd.

TOKYO OFFICE Tokyo Bldg., 1-10, 1 Chome, Ueno, Taito-ku, TOKYO, 110-8534 JAPAN

■ OSD

- Screen size : 36 characters × 16 lines
- Display RAM size : 704 words (1 word=10 bits)
 - Display area : 36 words × 16 lines
 - Control area : 8 words × 16 lines
- Font types : 16 × 32 font, 512 types (16 CGRAM fonts, including 4 fixed fonts)
An arbitrary number of characters can be generated as 16 × 17 or 8 × 9 font characters.
- Display colors : 4096 colors
Character text, background, borders, and full background can be displayed.
- Display mode specifiable on a line basis.
Normal, 4-color pixel map, 16-color pixel map, and caption text modes
- Vertical display start line and horizontal display start position specifiable on a line basis.
- Shutter function (specifying the display start or stop line) and scroll functions specifiable on a line basis.
- Horizontal character spacing (9 to 16 dots)^{*1} and vertical character spacing (1 to 32 dots) specifiable on a line basis.
- Character size selectable from 16 character sizes on a line basis^{*1}
(Horizontal×Vertical) = (1×1), (1×2), (2×1), (2×2), (2×4)
(4×2), (4×4), (4×8), (1.5×1), (1.5×2)
(3×1), (3×2), (3×4), (6×2), (6×4), (6×8)
- Cursor display function (4/16 pixel colors)
- Multilayer display
- Full screen display area specifiable.
- OSD clock selectable (normal speed mode/high speed mode/external input)
- Interlace/progressive scan selectable

*1: The supported range varies depending on the active display mode. Refer to the user's guide for details.

■ Data Slicer Function (closed caption format)

- Extracts closed caption data and XDS data.
- NTSC/PAL selectable and line specifiable.

■ Ports

- Normal withstand voltage I/O ports
 - Ports whose I/O direction can be designated in 1-bit units 41 (P1n, P2n, P3n, P70 to P73, P8n, PC0 to PC4)
 - Ports whose I/O direction can be designated in 4-bit units 8 (P0n)

■ Timers

- Timer 0: 16-bit timer/counter with a capture register.
 - Mode 0: 8-bit timer with an 8-bit programmable prescaler (with an 8-bit capture register) × 2 channels
 - Mode 1: 8-bit timer with an 8-bit programmable prescaler (with an 8-bit capture register) + 8-bit counter (with an 8-bit capture register)
 - Mode 2: 16-bit timer with an 8-bit programmable prescaler (with a 16-bit capture register)
 - Mode 3: 16-bit counter (with a 16-bit capture register)
- Timer 1: 16-bit timer/counter that supports PWM/toggle outputs
 - Mode 0: 8-bit timer with an 8-bit prescaler + with an 8-bit prescaler 8-bit timer/counter
 - Mode 1: 16-bit timer/counter with an 8-bit prescaler
- Timer 4: 8-bit timer with a 6-bit prescaler
- Timer 5: 8-bit timer with a 6-bit prescaler
- Base timer
 - 1) The clock is selectable from the subclock (32.768kHz crystal oscillation), system clock, and timer 0 prescaler output.
 - 2) Interrupts programmable in 5 different time schemes

■ High-speed Clock Counter

- 1) Can count clocks with a maximum clock rate of 28.2MHz (at a main clock of 14.1MHz).
- 2) Can generate output real-time.

■ SIO

- SIO0: 8-bit synchronous serial interface
 - 1) LSB first/MSB first mode selectable
 - 2) Built-in 8-bit baudrate generator (maximum transfer clock cycle =4/3 tCYC)
 - 3) Automatic continuous data transmission (1 to 256 bits, specifiable in 1 bit units, suspension and resumption of data transmission possible in 1 byte units)
- SIO1: 8-bit asynchronous/synchronous serial interface (bus mode 1 system)
 - Mode 0: Synchronous 8-bit serial I/O (2- or 3-wire configuration, 2 to 512 tCYC transfer clocks)
 - Mode 1: Asynchronous serial I/O (half-duplex, 8 data bits, 1 stop bit, 8 to 2048 tCYC baudrates)
 - Mode 2: Bus mode 1 (start bit, 8 data bits, 2 to 512 tCYC transfer clocks)
 - Mode 3: Bus mode 2 (start detect, 8 data bits, stop detect)
- SIO6: 8-bit asynchronous/synchronous serial interface (bus mode 2 system)
 - Mode 0: Synchronous 8-bit serial I/O (2- or 3-wire configuration, 2 to 512 tCYC transfer clocks)
 - Mode 1: Asynchronous serial I/O (half-duplex, 8 data bits, 1 stop bit, 8 to 2048 tCYC baudrates)
 - Mode 2: Bus mode 1 (start bit, 8 data bits, 2 to 512 tCYC transfer clocks)
 - Mode 3: Bus mode 2 (start detect, 8 data bits, stop detect)

■ UART

- Full duplex
- 7/8/9 data bits selectable
- 1 stop bit
- Built-in baudrate generator

■ AD Converter: 8 bits × 8 channels

■ PWM: 14-bit PWM × 1 channel 8-bit PWM × 3 channels

■ Remote Control Receiver Circuit (sharing with P73, INT3, and T0IN pins)

- Noise rejection function (noise filter time constant selectable from 1 tCYC, 32 tCYC, and 128 tCYC)

■ Watchdog Timer

- External RC watchdog timer
- Interrupt and reset signals selectable

■ High-speed Multiplication/Division Instructions

- 16 bits × 8 bits (5 tCYC execution time)
- 24 bits × 16 bits (12 tCYC execution time)
- 16 bits ÷ 8 bits (8 tCYC execution time)
- 24 bits ÷ 16 bits (12 tCYC execution time)

LC8740C8A/B2A/96A

■ Interrupts

- 21 sources, 10 vector addresses

- 1) Provides three levels (low (L), high (H), and highest (X)) of multiplex interrupt control. Any interrupt requests of the level equal to or lower than the current interrupt are not accepted.
- 2) When interrupt requests to two or more vector addresses occur at the same time, the interrupt of the highest level takes precedence over the other interrupts. For interrupts of the same level, the interrupt into the smallest vector address takes precedence.

No.	Vector Address	Level	Interrupt Source
1	00003H	X or L	INT0
2	0000BH	X or L	INT1
3	00013H	H or L	INT2/T0L
4	0001BH	H or L	INT3/base timer
5	00023H	H or L	T0H
6	0002BH	H or L	T1L/T1H
7	00033H	H or L	SIO0/UART1 receive
8	0003BH	H or L	SIO1/UART1 transmit/data slicer/SIO6
9	00043H	H or L	ADC/vertical sync (VS)/scan line
10	0004BH	H or L	Port 0/T4/T5

- Priority levels $X > H > L$
- Of interrupts of the same level, the one with the smallest vector address takes precedence.

■ Subroutine Stack Levels: 1024 levels maximum (the stack is allocated in RAM.)

■ Oscillation Circuits

- RC oscillation circuit (internal): For system clock
- VCO oscillation circuit (internal): For system clock generation and CRT display
- Crystal oscillation circuit: For low-speed system clock, base timer, and PLL reference

■ System Clock Divider Function

- Can run on low current.
- The minimum instruction cycle selectable from 212ns, 424ns, 848ns, 1.7 μ s, 3.4 μ s, 6.8 μ s, 13.6 μ s, 27.1 μ s, and 54.3 μ s (at a main clock rate of 14.1MHz).

■ Standby Function

- HALT mode: Halts instruction execution while allowing the peripheral circuits to continue operation.
 - 1) Oscillation is not halted automatically.
 - 2) Canceled by a system reset or occurrence of an interrupt
- HOLD mode: Suspends instruction execution and the operation of the peripheral circuits.
 - 1) The VCO, RC, and crystal oscillators automatically stop operation.
 - 2) There are three ways of resetting the HOLD mode.
 - (1) Setting the reset pin to the lower level.
 - (2) Setting at least one of the INT0, INT1, and INT2 pins to the specified level
 - (3) Having an interrupt source established at port 0

■ ROM Correction Function

- Executes the correction program on detection of a match with the program counter value.
- Correction program area size: 256 bytes (4 vector addresses)

■ Package Form

- QIP64E(14 \times 14): Lead-free type
- DIP64S(600mil): Lead-free type

■ Development Tools

- Flash ROM version: LC87F40C8A (Onchip debugger function is included.)
- Onchip debugger interface board: TCB87 (Type B)

Package Dimensions

unit : mm (typ)

3159A

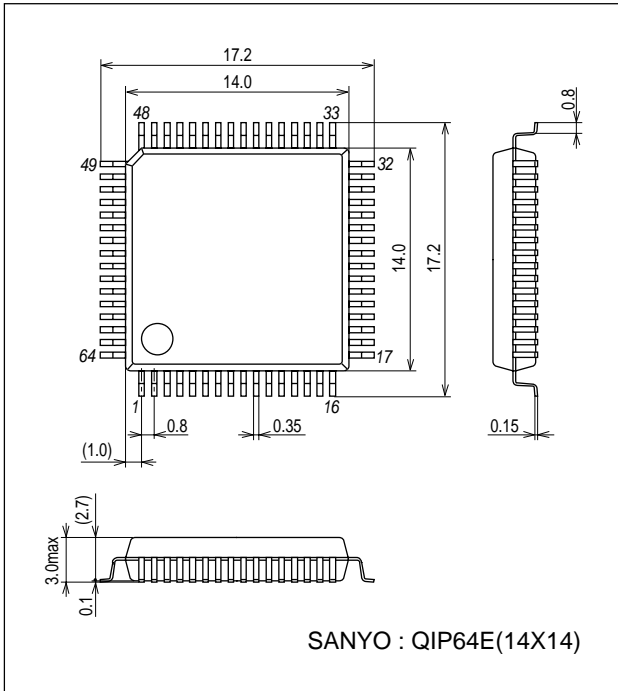

Package Dimensions

unit : mm (typ)

3300

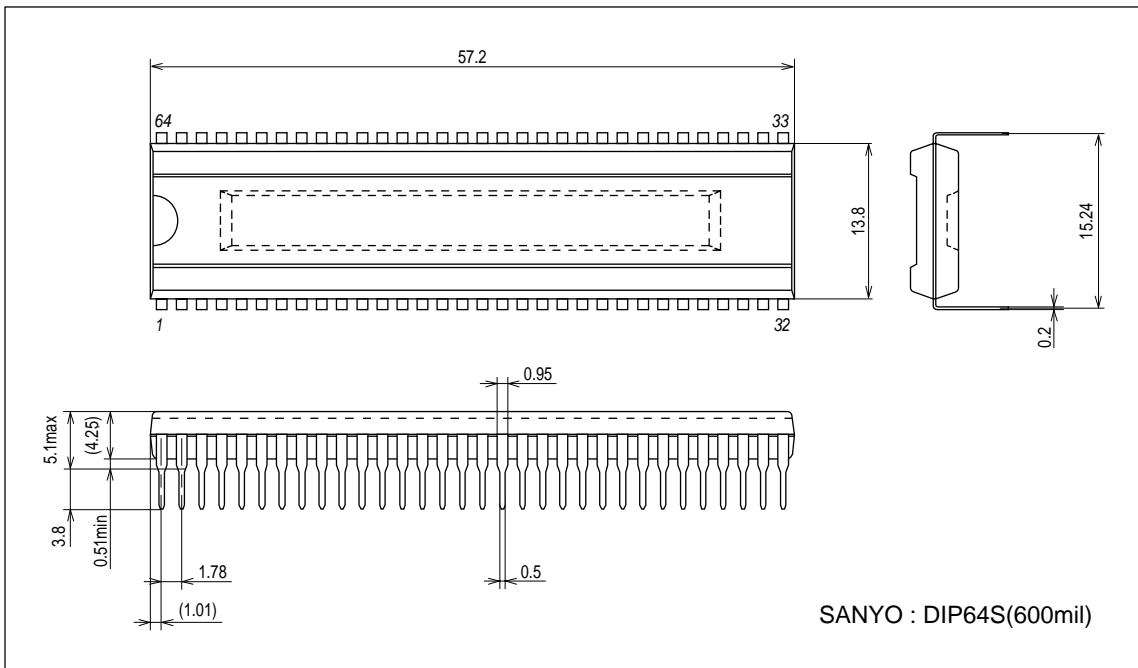

LC8740C8A/B2A/96A

Pin Assignments

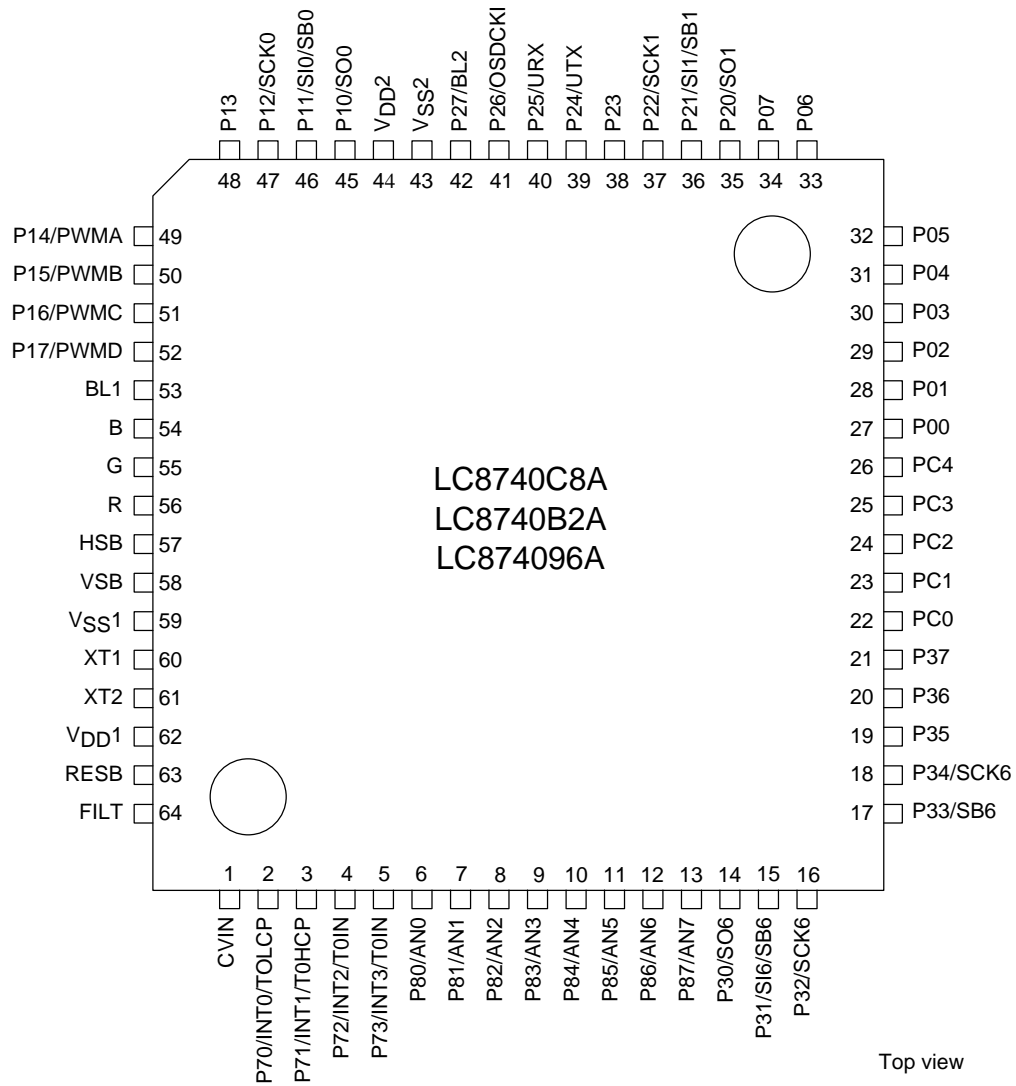

SANYO : QIP64E(14×14) “Lead-free Type”

LC8740C8A/B2A/96A

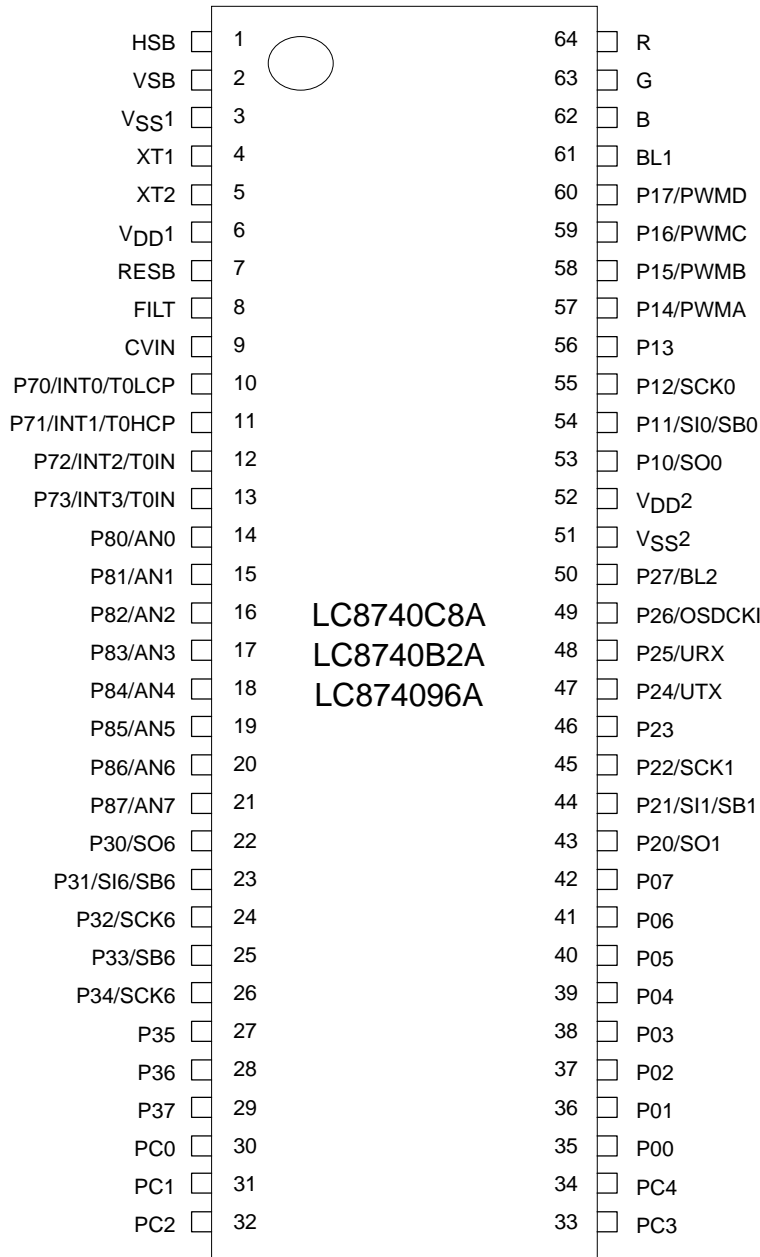

Top view

SANYO : DIP64S(600mil)

“Lead-free Type”

System Block Diagram

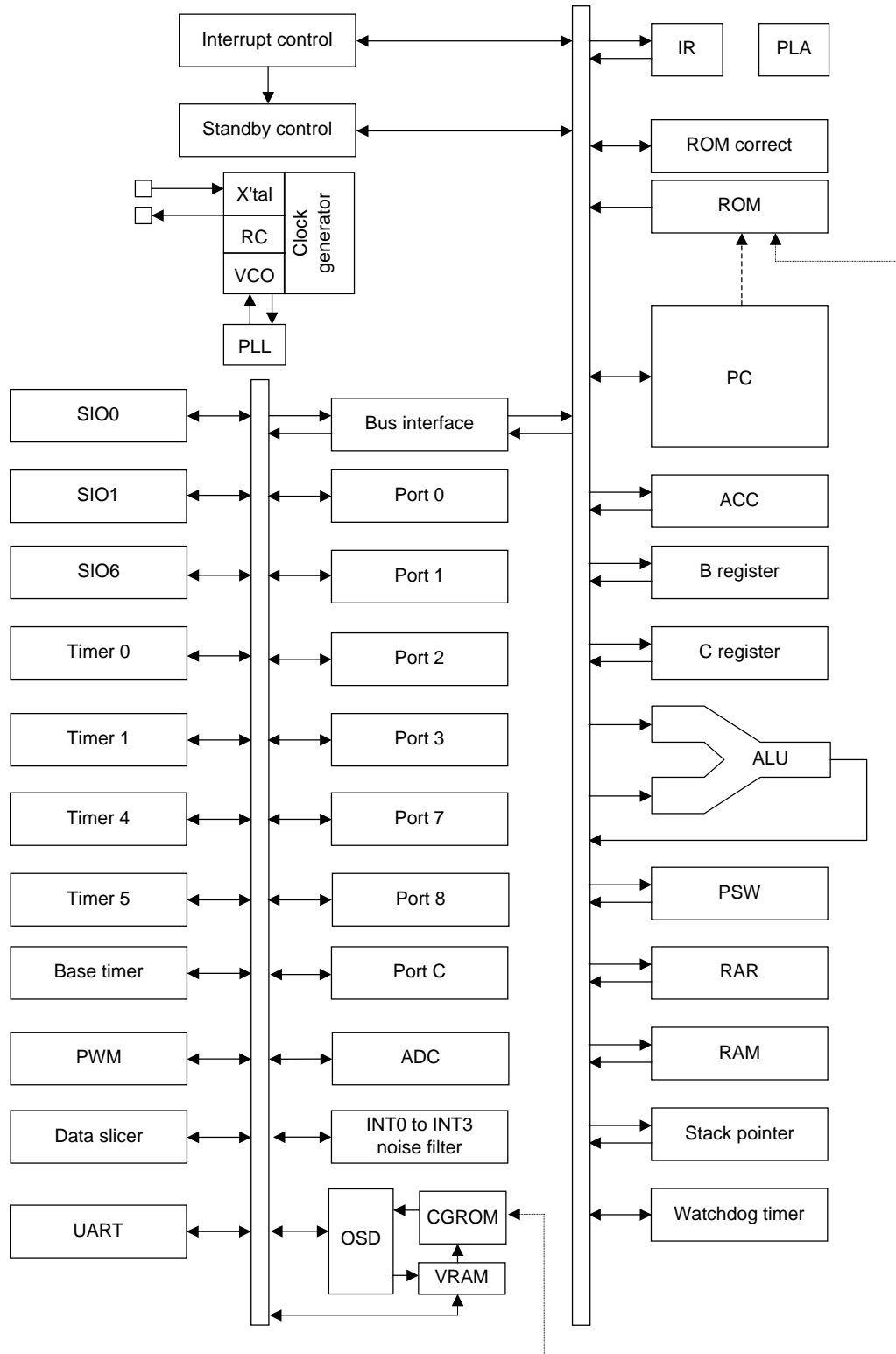

LC8740C8A/B2A/96A

Pin Description

Pin Name	I/O	Description	Option
V _{SS1} V _{SS2}	-	- power supply pin	No
V _{DD1} V _{DD2}	-	+ power supply pin	No
Port 0 P00 to P07	I/O	<ul style="list-style-type: none"> • 8-bit I/O port • I/O specifiable in 4-bit units • Pull-up resistors can be turned on and off in 4-bit units. • HOLD reset input • Port 0 interrupt input 	Yes
Port 1 P10 to P17	I/O	<ul style="list-style-type: none"> • 8-bit I/O port • I/O specifiable in 1-bit units • Pull-up resistors can be turned on and off in 1-bit units. • Pin functions <ul style="list-style-type: none"> P10: SIO0 data output P11: SIO0 data input/bus I/O P12: SIO0 clock I/O P14: PWMA output P15: PWMB output P16: PWMC output P17: PWMD output 	Yes
Port 2 P20 to P27	I/O	<ul style="list-style-type: none"> • 8-bit I/O port • I/O specifiable in 1-bit units • Pull-up resistors can be turned on and off in 1-bit units. • Pin functions <ul style="list-style-type: none"> P20: SIO1 data output P21: SIO1 data input/bus I/O P22: SIO1 clock I/O P24: UART transmit P25: UART receive P26: External OSD clock input P27: Fast blanking 2 control signal output 	Yes
Port 3 P30 to P37	I/O	<ul style="list-style-type: none"> • 8-bit I/O port • I/O specifiable in 1-bit units • Pull-up resistors can be turned on and off in 1-bit units. • Pin functions <ul style="list-style-type: none"> P30: SIO6 data output P31: SIO6 data input/bus I/O P32: SIO6 clock I/O P33: SIO6 bus I/O P34: SIO6 clock I/O 	Yes

Continued on next page.

LC8740C8A/B2A/96A

Continued from preceding page.

Pin Name	I/O	Description	Option																														
Port 7 P70 to P73	I/O	<ul style="list-style-type: none"> • 4-bit I/O port • I/O specifiable in 1-bit units • Pull-up resistors can be turned on and off in 1-bit units. • Shared pins P70: INT0 input/HOLD reset input/timer 0L capture input/watchdog timer output P71: INT1 input/HOLD reset input/timer 0H capture input P72: INT2 input/HOLD reset input/timer 0 event input/timer 0L capture input P73: INT3 input (with noise filter input)/timer 0 event input/timer 0H capture input Interrupt acknowledge type <table border="1" style="margin-left: 20px; width: 100%;"> <thead> <tr> <th></th> <th>Rising</th> <th>Falling</th> <th>Rising & Falling</th> <th>H Level</th> <th>L Level</th> </tr> </thead> <tbody> <tr> <td>INT0</td> <td>enable</td> <td>enable</td> <td>disable</td> <td>enable</td> <td>enable</td> </tr> <tr> <td>INT1</td> <td>enable</td> <td>enable</td> <td>disable</td> <td>enable</td> <td>enable</td> </tr> <tr> <td>INT2</td> <td>enable</td> <td>enable</td> <td>enable</td> <td>disable</td> <td>disable</td> </tr> <tr> <td>INT3</td> <td>enable</td> <td>enable</td> <td>enable</td> <td>disable</td> <td>disable</td> </tr> </tbody> </table>		Rising	Falling	Rising & Falling	H Level	L Level	INT0	enable	enable	disable	enable	enable	INT1	enable	enable	disable	enable	enable	INT2	enable	enable	enable	disable	disable	INT3	enable	enable	enable	disable	disable	No
	Rising	Falling	Rising & Falling	H Level	L Level																												
INT0	enable	enable	disable	enable	enable																												
INT1	enable	enable	disable	enable	enable																												
INT2	enable	enable	enable	disable	disable																												
INT3	enable	enable	enable	disable	disable																												
Port 8 P80 to P87	I/O	<ul style="list-style-type: none"> • 8-bit I/O port • I/O specifiable in 1-bit units • Shared pins AD converter input: AN0 (P80) to AN7 (P87)	No																														
Port C PC0 to PC4	I/O	<ul style="list-style-type: none"> • 5-bit I/O port • I/O specifiable in 1-bit units • Pull-up resistors can be turned on and off in 1-bit units. 	Yes																														
$\overline{\text{RES}}$	Input	Reset pin	No																														
XT1	Input	• 32.768kHz crystal oscillator input pin	No																														
XT2	I/O	• 32.768kHz crystal oscillator output pin	No																														
FILT	Output	• Internal PL filter pin	No																														
CVIN	Input	• Video input pin	No																														
VS	Input	• Vertical sync input pin	No																														
HS	Input	• Horizontal sync input pin	No																														
R	Output	• Red (R) RGB video output pin	No																														
G	Output	• Green (G) RGB video output pin	No																														
B	Output	• Blue (B) RGB video output pin	No																														
BL1	Output	• Fast blanking 1 control output pin	No																														

LC8740C8A/B2A/96A

Port Output Types

The table below lists the types of port outputs and the presence/absence of a pull-up resistor.

Data can be read into any input port even if it is in the output mode.

Port name	Option Selected in Units of	Option Type	Output Type	Pull-up Resistor
P00 to P07	1 bit	1	CMOS	Programmable (Note 1)
		2	Nch-open drain	No
P10 to P17 P20 to P27 P30 to P37	1 bit	1	CMOS	Programmable
		2	Nch-open drain	Programmable
P70	-	No	Nch-open drain	Programmable
P71 to P73	-	No	CMOS	Programmable
P80 to P87	-	No	Nch-open drain	No
PC0 to PC4	1 bit	1	CMOS	Programmable
		2	Nch-open drain	Programmable

Note 1: Programmable pull-up resistors for port 0 are controlled in 4-bit units (P00 to 03, P04 to 07).

*1 Connect the IC as shown below to minimize the noise input to the V_{DD1} pin.
Be sure to electrically short the V_{SS1} and V_{SS2} pins.

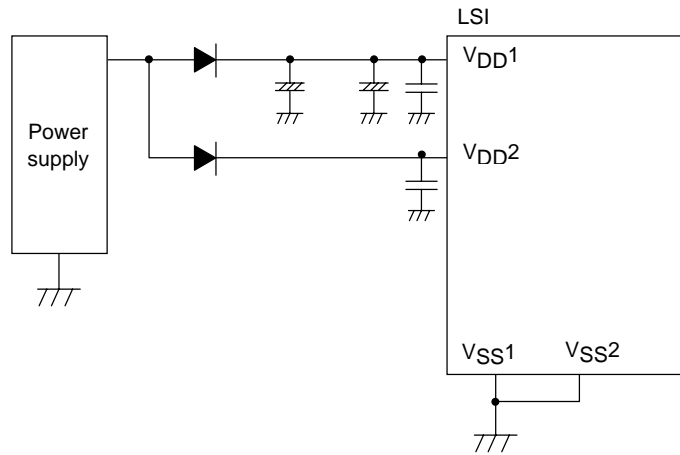

LC8740C8A/B2A/96A

Absolute Maximum Ratings at Ta = 25°C, VSS1 = VSS2 = 0V

Parameter	Symbol	Pin/Remarks	Conditions	Specification				unit
				VDD[V]	min	typ	max	
Maximum supply voltage	VDD max	VDD1, VDD2	VDD1=VDD2		-0.3		+6.5	V
Input voltage	VI(1)	XT1, RES, HS, VS CVIN			-0.3		VDD+0.3	
Output voltage	VO(1)	XT2, BL1, R, G, B FILT			-0.3		VDD+0.3	
Input/output voltage	VI(1)	Ports 0, 1, 2, 3 Ports 7, 8 Port C			-0.3		VDD+0.3	
High level output current	Peak output current (Note 1-1)	IOPH(1)	Ports 0, 1, 2, 3, C BL	CMOS output select Per 1 applicable pin		-10		mA
		IOPH(2)	Ports 71 to 73	Per 1 applicable pin		-5		
		IOPH(3)	R, G, B	OSD is digital mode Per 1 applicable pin		-10		
	Total output current	ΣIOAH(1)	Port 7	Total of all applicable pins		-25		
		ΣIOAH(2)	Port 0, 2, 3, C	Total of all applicable pins		-25		
		ΣIOAH(3)	Ports 1 R, G, B, BL	Total of all applicable pins		-25		
Low level output current	Peak output current (Note 1-1)	IOPL(1)	Ports 0, 1, 2, 3, C BL	Per 1 applicable pin			20	
		IOPL(2)	Ports 7, 8	Per 1 applicable pin			10	
		IOPL(3)	R, G, B	OSD is digital mode Per 1 applicable pin			20	
	Total output current	ΣIOAL(1)	Ports 7, 8	Total of all applicable pins			20	
		ΣIOAL(2)	Ports 0, 2, 3, C	Total of all applicable pins			45	
		ΣIOAL(3)	Port 1 R, G, B, BL	Total of all applicable pins			45	
Allowable power dissipation	Pd max	QIP64E(14×14)	Ta=-10 to +70°C				390	mW
		DIP64S(600mil)					880	
Operating ambient temperature	Topr				-10		+70	°C
Storage ambient temperature	Tstg				-55		+125	

Note 1-1: The average current per applicable pin must not exceed 10mA

LC8740C8A/B2A/96A

Allowable Operating Conditions at Ta = -10°C to +70°C, VSS1 = VSS2 = 0V

Parameter	Symbol	Pin/Remarks	Conditions		Specification						
					VDD[V]	min	typ	max	unit		
Operating supply voltage	VDD(1)	VDD1=VDD2	0.211μs≤tCYC≤200μs			4.5		5.5	V		
Memory sustaining supply voltage	VHD	VDD1=VDD2	RAM and register contents sustained in HOLD mode			2.0		5.5			
High level input voltage	VIH(1)	Ports 0, 1, 2, 3 P71 to P73, 8, C P70 port input/ interrupt side HS, VS			4.5 to 5.5	0.3VDD +0.7		VDD			
	VIH(2)	Port 70 watchdog timer side			4.5 to 5.5	0.9VDD		VDD			
	VIH(3)	XT1, RES			4.5 to 5.5	0.75VDD		VDD			
Low level input voltage	VIL(1)	Ports 0, 1, 2, 3 P71 to P73, 8, C P70 port input/ interrupt side HS, VS			4.5 to 5.5	VSS		0.1VDD +0.4			
	VIL(2)	Port 70 watchdog timer side			4.5 to 5.5	VSS		0.15VDD +0.4			
	VIL(3)	XT1, RES			4.5 to 5.5	VSS		0.25VDD			
CVIN input amplitude	VCVIN	CVIN			5.0	1Vp-p -3dB	1Vp-p	1Vp-p +3dB		Vp-p	
Instruction cycle time	tcyc(1) (Note 2-1)		All functions		4.5 to 5.5	0.211	0.212	0.213	μs		
	tcyc(2) (Note 2-1)		Except for OSD and data slicer functions		4.5 to 5.5	0.211		200	μs		
External OSD clock frequency	FEXOS(1)	P26/OSDCK1	DUTY50±5% of external OSD clock (Note 2-3)	SCON1=0	4.5 to 5.5			14.28	15.44	MHz	
	FEXOS(2)			SCON1=1				28.56	30.88		
Oscillation frequency range (Note 2-2)	FmVCO1		Internal VCO1 oscillator		4.5 to 5.5	14.08	14.15	14.22	MHz		
	FmVCO2		Internal VCO2 Oscillator (Note 2-3)	CKSEL0=0	4.5 to 5.5			14.28		14.75	15.44
				CKSEL0=1				28.56		29.5	30.88
	FmRC		Internal RC oscillator		4.5 to 5.5	0.3	1.0	2.0			
FsX'tal	XT1, XT2	32.768kHz crystal oscillation mode See Fig. 1.		4.5 to 5.5		32.768		kHz			

Note 2-1: Relationship between tCYC and oscillation frequency is 3/FmVCO1 at a division ratio of 1/1 and 6/FmVCO1 at a division ratio of 1/2.

Note 2-2: See Table 1 for the oscillation constants

Note 2-3: SCAN1 is Hsync frequency switch bit. CKSEL0 is OSD clock frequency switch bit.
(Refer to the LC874000 user's manual for details.)

LC8740C8A/B2A/96A

Electrical Characteristics at Ta = -10°C to +70°C, VSS1 = VSS2 = 0V

Parameter	Symbol	Pin/Remarks	Conditions	Specification				unit
				VDD[V]	min	typ	max	
High level input current	I _{IH} (1)	Ports 0, 1, 2, 3 Ports 7, 8 Port C	Output disabled Pull-up resistor off V _{IN} =V _{DD} (including output Tr's off leakage current)	4.5 to 5.5			1	μA
	I _{IH} (2)	$\overline{\text{RES}}$, HS, VS	V _{IN} =V _{DD}	4.5 to 5.5			1	
Low level input current	I _{IL} (1)	Ports 0, 1, 2, 3 Ports 7, 8 Port C	Output disabled Pull-up resistor off V _{IN} =V _{SS} (including output Tr's off leakage current)	4.5 to 5.5	-1			μA
	I _{IL} (2)	$\overline{\text{RES}}$, HS, VS	V _{IN} =V _{SS}	4.5 to 5.5	-1			
High level output voltage	V _{OH} (1)	Ports 0, 1, 2, 3, 8 Port C	I _{OH} =-1.0mA	4.5 to 5.5	V _{DD} -1			V
	V _{OH} (2)	P71 to P73	I _{OH} =-0.4mA	4.5 to 5.5	V _{DD} -1			
	V _{OH} (3)	R, G, B	I _{OH} =-5mA	4.5 to 5.5	V _{DD} -1			
	V _{OH} (4)	BL1, P27/BL2	I _{OH} =-5mA When BL2 is output	4.5 to 5.5	V _{DD} -1			
Low level output voltage	V _{OL} (1)	Ports 0, 1, 2, 3, 8 Port C	I _{OL} =10mA	4.5 to 5.5			1.5	V
			I _{OL} =1.6mA	4.5 to 5.5			0.4	
	V _{OL} (2)	Port 7	I _{OL} =1mA	4.5 to 5.5			0.4	
	V _{OL} (3)	R, G, B	I _{OL} =5mA	4.5 to 5.5			0.4	
V _{OL} (4)	BL1, P27/BL2	I _{OL} =5mA When BL2 is output	4.5 to 5.5			0.4		
Pull-up resistance	R _{pu}	Ports 0, 1, 2, 3, 7 Ports 8, C	V _{OH} =0.9V _{DD}	4.5 to 5.5	15	40	70	kΩ
Hysteresis voltage	V _{HYS}	$\overline{\text{RES}}$ Ports 1, 2, 3, 7 HS, VS		4.5 to 5.5		0.35		V
Bus terminal short circuit resistance for internal communication	R _{BS}	• P31, P33 • P32, P34				130	300	Ω
Pin capacitance	CP	All pins	For pins other than that under test: V _{IN} =V _{SS} f=1MHz Ta=25°C	4.5 to 5.5			10	pF

LC8740C8A/B2A/96A

Serial I/O Characteristics at Ta = -10°C to +70°C, V_{SS1} = V_{SS2} = 0V

1. SIO0 Serial I/O Characteristics (Note 4-1-1)

Parameter	Symbol	Pin/ Remarks	Conditions	Specification						
				V _{DD} [V]	min	typ	max	unit		
Serial clock	Input clock	Period	tSCK(1)	SCK0(P12) See Fig. 5.	4.5 to 5.5	2			tCYC	
		Low level pulse width	tSCKL(1)			1				
		High level pulse width	tSCKH(1)			1				
			tSCKHA(1a)			4				
	tSCKHA(1b)	6								
	Output clock		Period	tSCK(2)		SCK0(P12) • CMOS output selected • See Fig. 5.	4.5 to 5.5	4/3		
		Low level pulse width	tSCKL(2)	1/2						
		High level pulse width	tSCKH(2)	1/2						
tSCKHA(2a)			tSCKH(2) +2tCYC	tSCKH(2) +(10/3) tCYC	tCYC					
tSCKHA(2b)	tSCKH(2) +2tCYC	tSCKH(2) +(16/3) tCYC								
Serial input			Data setup time	tsDI(1)	SIO(P11), SB0(P11) • Must be specified with respect to rising edge of SIOCLK. • See Fig. 5.	4.5 to 5.5		0.03		
	Data hold time	thDI(1)	0.03							
Serial output	Input clock	Output delay time	tdD0(1)	SO0(P10), SB0(P11) • Continuous data transmission/ reception mode • (Note4-1-3)	4.5 to 5.5				(1/3)tCYC +0.05	μs
			tdD0(2)			• Synchronous 8-bit mode • (Note4-1-3)			1tCYC +0.05	
	Output clock	tdD0(3)	(Note4-1-3)					(1/3)tCYC +0.05		

Note4-1-1: This standard value is a theory value. Be sure to ensure the margin according to busy condition.

Note4-1-2: When using the serial clock in continuous data transmission/reception mode, the time to the first falling edge of the serial clock after it sets SIORUN in “H” state is more extended than tSCLKHA.

Note4-1-3: It is defined for the falling edge of SIOCLK. In open drain output, it is defined as the time to start the output change. See Fig. 5.

LC8740C8A/B2A/96A

2. SIO1, 6 Serial I/O Characteristics (Note 4-2-1)

Parameter		Symbol	Pin/Remarks	Conditions	V _{DD} [V]	Specification				
						min	typ	max	unit	
Serial clock	Input clock	Period	tSCK(3)	SCK1(P22), SCK6(P32, 34)	See Fig. 5.	4.5 to 5.5	2			tCYC
		Low level pulse width	tSCKL(3)				1			
		High level pulse width	tSCKH(3)				1			
	Output clock	Period	tSCK(4)	SCK1(P22), SCK6(P32, 34)	<ul style="list-style-type: none"> • CMOS output selected • See Fig. 5. 	4.5 to 5.5	2			tSCK
		Low level pulse width	tSCKL(4)				1/2			
		High level pulse width	tSCKH(4)				1/2			
Serial input	Data setup time	tsDI(2)	SI1(P21), SB1(P21), SI6(P31), SB6(P31, P33)	<ul style="list-style-type: none"> • Must be specified with respect to rising edge of SIOCLK. • See Fig. 5. 	4.5 to 5.5	0.03				
	Data hold time	thDI(2)				0.03				
Serial output	Output delay time	tdD0(4)	SO1(P20), SB1(P21), SO6(P30), SB6(P31, P34)	<ul style="list-style-type: none"> • Must be specified with respect to falling edge of SIOCLK. • Must be specified as the time to the beginning of output state change in open drain output mode. • See Fig. 5. 	4.5 to 5.5			1/3tCYC +0.05	μs	

Note4-2-1: This standard value is a theory value. Be sure to ensure the margin according to busy condition.

LC8740C8A/B2A/96A

Pulse Input Conditions at Ta = -10°C to +70°C, VSS1 = VSS2 = 0V

Parameter	Symbol	Pin/Remarks	Conditions	Specification				
				VDD[V]	min	typ	max	unit
High/low level pulse width	tPIH(1) tPIL(1)	INT0(P70), INT1(P71), INT2(P72),	<ul style="list-style-type: none"> Interrupt source flag can be set. Event inputs for timers 0 and 1 are enabled. 	4.5 to 5.5	1			tCYC
	tPIH(2) tPIL(2)	INT3(P73) when noise filter time constant is 1/1	<ul style="list-style-type: none"> Interrupt source flag can be set. Event inputs for timer 0 are enabled. 	4.5 to 5.5	2			
	tPIH(3) tPIL(3)	INT3(P73) when noise filter time constant is 1/32	<ul style="list-style-type: none"> Interrupt source flag can be set. Event inputs for timer 0 are enabled. 	4.5 to 5.5	64			
	tPIH(4) tPIL(4)	INT3(P73) when noise filter time constant is 1/128	<ul style="list-style-type: none"> Interrupt source flag can be set. Event inputs for timer 0 are enabled. 	4.5 to 5.5	256			
	tPIL(5)	$\overline{\text{RES}}$	Resetting is enabled.	4.5 to 5.5	200			μs
	tPIH(6) tPIL(6)	$\overline{\text{HS}}, \overline{\text{VS}}$	<ul style="list-style-type: none"> Display position controllable (Note) The active edge of $\overline{\text{HS}}$ and $\overline{\text{VS}}$ must be apart at least 1 tCYC. See Fig. 7. 	4.5 to 5.5	1			
Falling time	tTHL	$\overline{\text{HS}}$	See Fig. 7. (Note 5-1)	4.5 to 5.5			100	ns
External OSD clock input frequency	tOSCKI	OSDCKI(P26)	See Fig. 8.	4.5 to 5.5	10			ns

Note 5-1: When the falling edge of $\overline{\text{HS}}$ is affected by the noise, the start position of OSD can slip off. Note that the signal lines with rapid state change or with large current should be allocated away from $\overline{\text{HS}}$ line.

AD Converter Characteristics at Ta = -10°C to +70°C, VSS1 = VSS2 = 0V

Parameter	Symbol	Pin/Remarks	Conditions	Specification				
				VDD[V]	min	typ	max	unit
Resolution	N	AN0(P80) to AN7(P87)		4.5 to 5.5		8		bit
Absolute accuracy	ET		(Note 6-1)	4.5 to 5.5			± 1.5	LSB
Conversion time	TCAD		AD conversion time=32×tCYC (when ADCR2=0) (Note 6-2)	4.5 to 5.5	13.50 (tCYC=0.422 μs)		97.92 (tCYC=3.06 μs)	μs
			AD conversion time=64×tCYC (when ADCR2=1) (Note 6-2)	4.5 to 5.5	13.50 (tCYC=0.211 μs)		97.92 (tCYC=1.53 μs)	
Analog input voltage range	VAIN			4.5 to 5.5	VSS		VDD	V
Analog port input current	IAINH		VAIN=VDD	4.5 to 5.5			1	μA
	IAINL		VAIN=VSS	4.5 to 5.5	-1			

Note 6-1: The quantization error ($\pm 1/2\text{LSB}$) is excluded from the absolute accuracy value.

Note 6-2: The conversion time refers to the interval from the time the instruction for starting the converter is issued till the time the complete digital value corresponding to the analog input value is loaded in the required register.

LC8740C8A/B2A/96A

Analog mode RGB Characteristics at $T_a = -10^\circ\text{C}$ to $+70^\circ\text{C}$, $V_{SS1} = V_{SS2} = 0\text{V}$

Parameter	Symbol	Pin/Remarks	Conditions	Specification			
				min	typ	max	unit
Output resistance		R, G, B	$V_{DD} = 5.0\text{V}$			2.5	$\text{k}\Omega$
Analog output deflection	VARO	R, G, B	$V_{DD} = 5.0\text{V}$			20	%
Time setting	tST	R, G, B	70%DC level 10pf load			50	ns

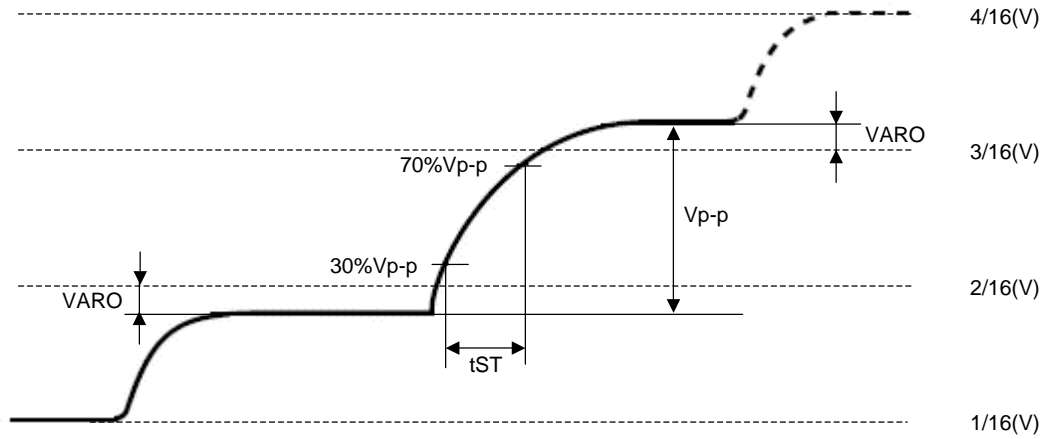

LC8740C8A/B2A/96A

Current Drain Characteristics at Ta = -10°C to +70°C, V_{SS1} = V_{SS2} = 0V

Parameter	Symbol	Pin/ Remarks	Conditions	Specification				
				V _{DD} [V]	min	typ	Max	unit
Normal mode current drain (Note 7-1)	IDDOP(1)	V _{DD1} =V _{DD2}	<ul style="list-style-type: none"> • FmX'tal=32.768kHz crystal oscillation mode • System clock set to main clock VCO • OSD VCO active • Internal RC oscillator inactive • 1/1 frequency division ratio • OSD is analog mode • DSL active 	4.5 to 5.5		38	56	mA
	IDDOP(2)		<ul style="list-style-type: none"> • FmX'tal=32.768kHz crystal oscillation mode • System clock set to main clock VCO • OSD VCO active • Internal RC oscillator inactive • 1/1 frequency division ratio • OSD is digital mode • DSL active 	4.5 to 5.5		30	48	
	IDDOP(3)		<ul style="list-style-type: none"> • FmX'tal=32.768kHz crystal oscillation mode • System clock set to 32.768kHz • Main clock and OSD VCOs inactive • Internal RC oscillator inactive • 1/2 frequency division ratio 	4.5 to 5.5		81	300	μA
HALT mode current drain (Note 7-1)	IDDHALT(1)		HALT mode <ul style="list-style-type: none"> • FmX'tal=32.768kHz crystal oscillation mode • System clock set to main clock VCO • OSD VCO active • Internal RC oscillator inactive • 1/1 frequency division ratio 	4.5 to 5.5		4	8	mA
	IDDHALT(2)		HALT mode <ul style="list-style-type: none"> • FmX'tal=32.768kHz crystal oscillation mode • System clock set to internal RC oscillator • 1/1 frequency division ratio 	4.5 to 5.5		400	1400	
	IDDHALT(3)		HALT mode <ul style="list-style-type: none"> • FmX'tal=32.768kHz crystal oscillation mode • System clock set to 32.768kHz • Main and OSD VCOs inactive • Internal RC oscillator inactive • 1/2 frequency division ratio 	4.5 to 5.5		73	200	μA
HOLD mode current drain	IDDHOLD	V _{DD1}	HOLD mode <ul style="list-style-type: none"> • All oscillators inactive 	4.5 to 5.5		0.05	20	

Note 7-1: The current drain value includes none of the currents that flow into the output transistors and internal pull-up resistors.

LC8740C8A/B2A/96A

UART (Full Duplex) Operating Conditions at Ta=-10°C to +70°C, VSS1=VSS2=0V

Parameter	Symbol	Pin/ Remarks	Conditions	Specification				
				V _{DD} [V]	min	typ	max	unit
Transfer rate	UBR	P24, P25		4.5 to 5.5	16/3		8192/3	tCYC

Data length: 7/8/9 bits (LSB first)

Stop bits: 1 bit

Parity bits: None

Example of Continuous 8-bit Data Transmission Mode Processing (First Transmit Data=55H)

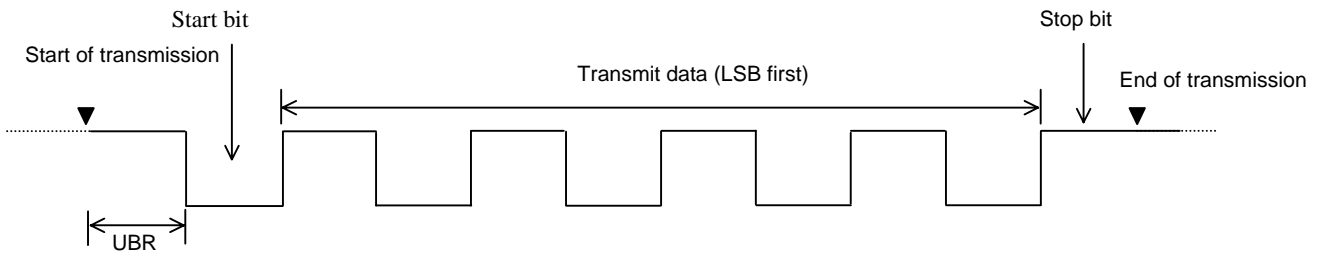

Example of Continuous 8-bit Data Reception Mode Processing (First Receive Data=55H)

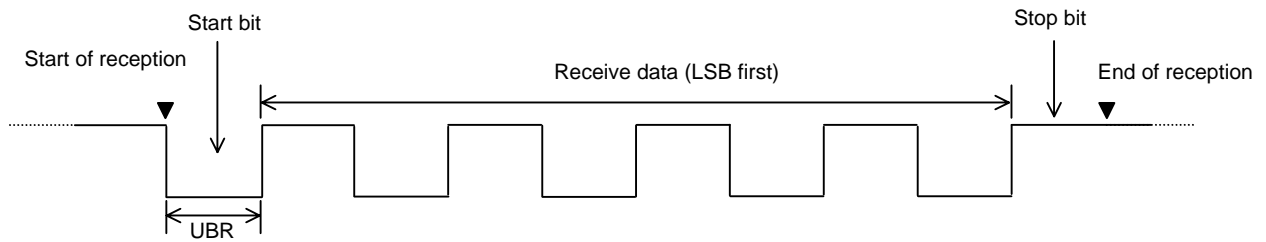

Recommended Oscillation Circuit and Sample Characteristics

The sample oscillation circuit characteristics in the table below is based on the following conditions:

- Recommended circuit parameters are verified by an oscillator manufacturer using a Sanyo provided oscillation evaluation board.
- Sample characteristics are the result of the evaluation with the recommended circuit parameters connected externally.

Table 1. Recommended oscillation circuit and sample characteristics (Ta = -10°C to +70°C)

Frequency	Manufacturer	Oscillator	Recommended circuit parameters				Operating supply voltage range [V]	Oscillation stabilizing time		Remarks
			C1 [pF]	C2 [pF]	Rf [Ω]	Rd [Ω]		typ [s]	max [s]	
32.768kHz	Seiko Epson	C-002RX	18	18	OPEN	620k	4.5 to 5.5	1.00	1.50	

Notes: The oscillation stabilizing time period is the time until the VCO oscillation for the internal system becomes stable after the following conditions. (See Figure 3.)

1. The VDD becomes higher than the minimum operating voltage after the power is supplied.
2. The HOLD mode is released.

The sample oscillation circuit characteristics may differ applications. For further assistance, please contact with oscillator manufacturer with the following notes in your mind.

- Since the oscillation frequency precision is affected by wiring capacity of the application board, etc., adjust the oscillation frequency on the production board.
- The above oscillation frequency and the operating supply voltage range are based on the operating temperature of -10°C to +70°C. For the use with the temperature outside of the range herein, or in the application requiring high reliability such as car products, please consult with oscillator manufacturer.
- When using the oscillator which is not shown in the sample oscillation circuit characteristics, please consult with Sanyo sales personnel.

Since the oscillation circuit characteristics are affected by the noise or wiring capacity because the circuit is designed with low gain in order to reduce the power dissipation, refer to the following notices.

- The distance between the clock I/O terminal (XT1 terminal XT2 terminal) and external parts should be as short as possible.
- The capacitors' VSS should be allocated close to the microcontroller's GND terminal and be away from other GND.
- The signal lines with rapid state change or with large current should be allocated away from the oscillation circuit.

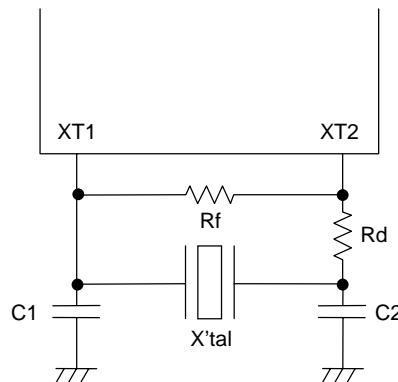

Figure 1 Recommended Oscillation Circuit

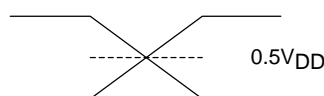
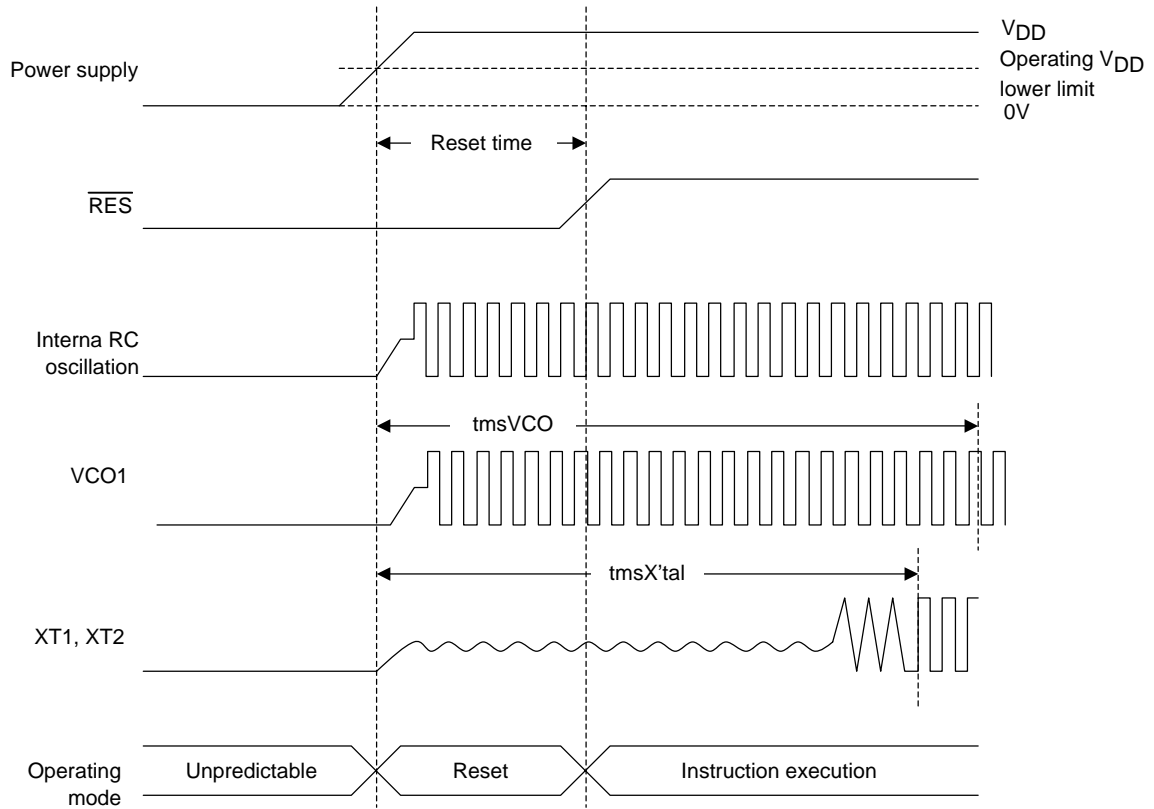
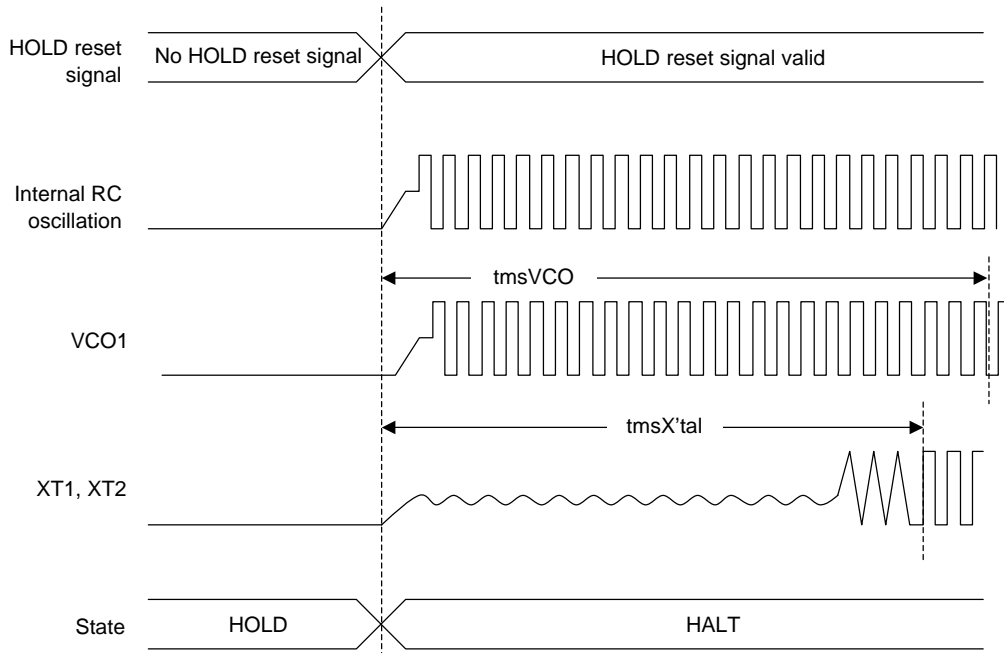

Figure 2 AC Timing Measurement Point

LC8740C8A/B2A/96A



Reset Time and Oscillation Stabilization Time



HOLD Reset Signal and Oscillation Stabilization Time

Figure 3 Oscillation Stabilization Timing

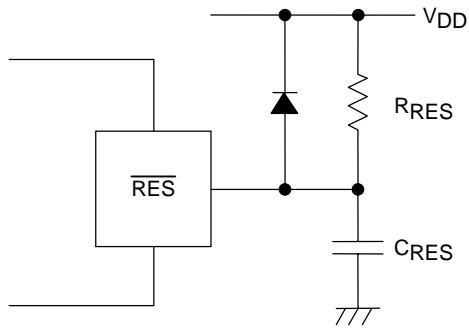

Note:
Determine the value of C_{RES} and R_{RES} so that the reset signal is present for a period of $200\mu s$ after the supply voltage goes beyond the lower limit of the IC's operating voltage.

Figure 4 Reset Circuit

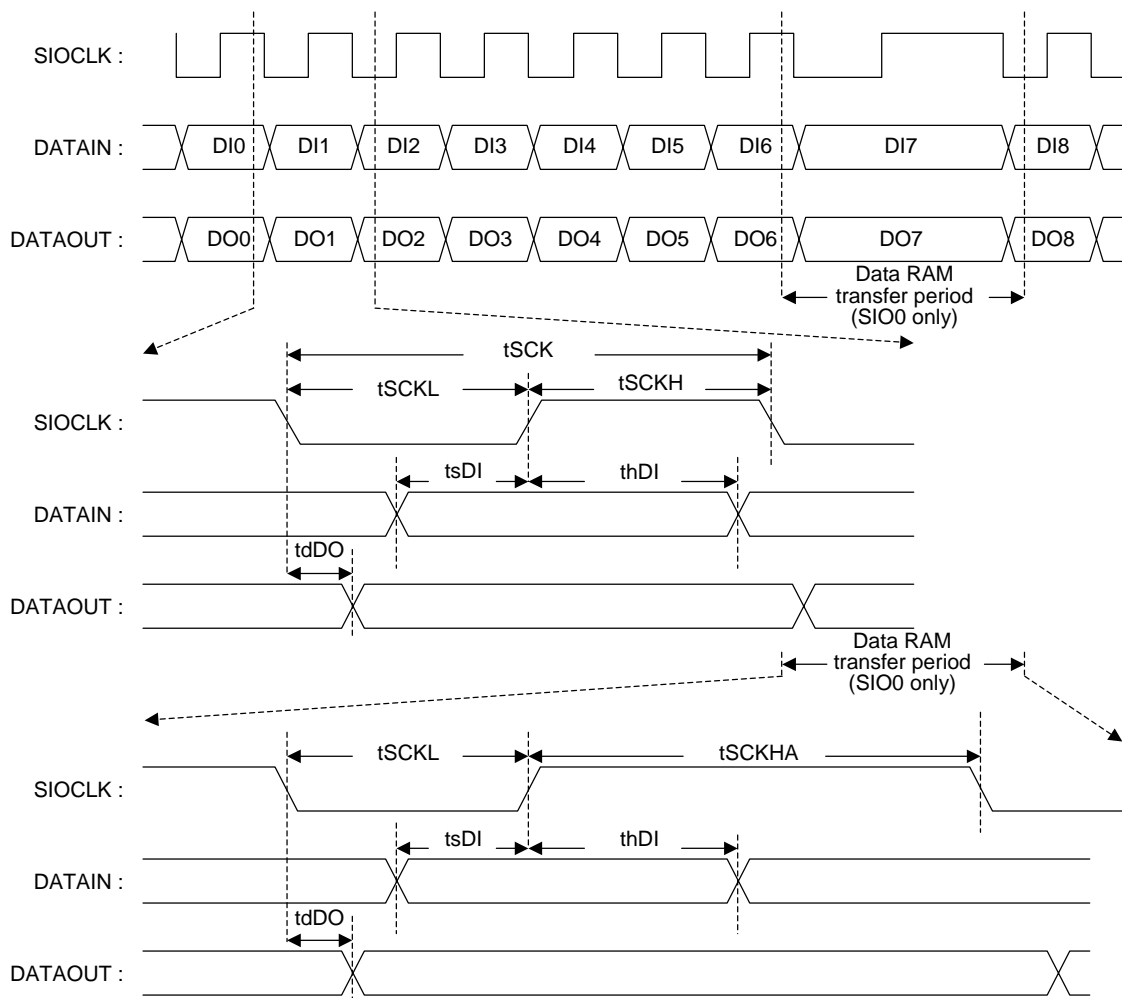

Figure 5 Serial I/O Output Waveforms

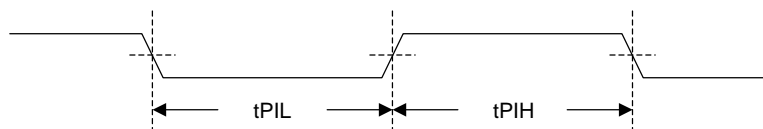

Figure 6 Pulse Input Timing Signal Waveform 1

LC8740C8A/B2A/96A

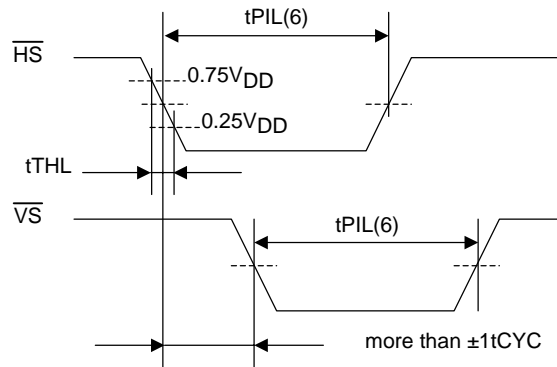
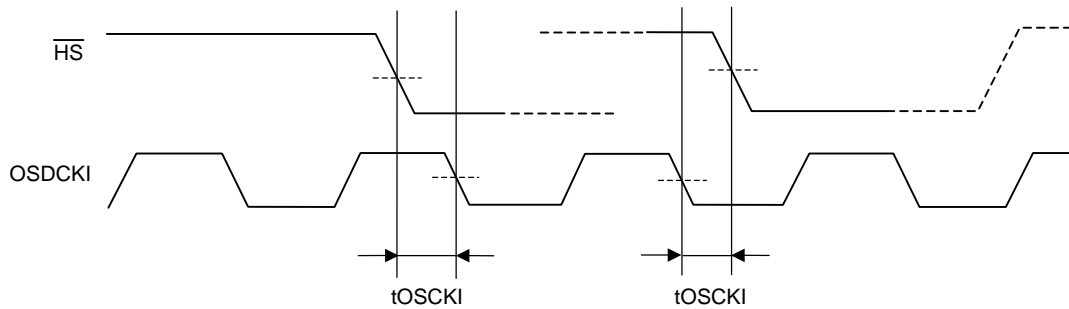
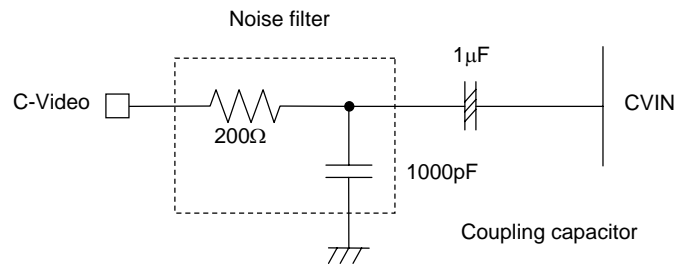

Figure 7 Pulse Input Timing Signal Waveform 2



Note: Last transition of the tOSCKI must be saving constant.

Figure 8 Pulse Input Timing Signal Waveform 3



Note: The output impedance of the C-Video side as viewed from the input of the noise filter must be 100Ω or less.

Figure 9 Recommended CVIN Circuit

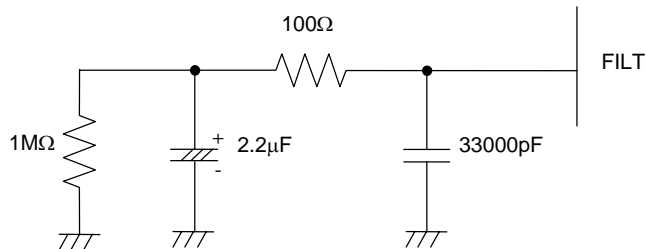

Note: Place the components to be connected to the FILTER pin so that their trace length is minimum.

Figure 10 Recommended Filter Circuit

- Specifications of any and all SANYO Semiconductor products described or contained herein stipulate the performance, characteristics, and functions of the described products in the independent state, and are not guarantees of the performance, characteristics, and functions of the described products as mounted in the customer's products or equipment. To verify symptoms and states that cannot be evaluated in an independent device, the customer should always evaluate and test devices mounted in the customer's products or equipment.
- SANYO Semiconductor Co., Ltd. strives to supply high-quality high-reliability products. However, any and all semiconductor products fail with some probability. It is possible that these probabilistic failures could give rise to accidents or events that could endanger human lives, that could give rise to smoke or fire, or that could cause damage to other property. When designing equipment, adopt safety measures so that these kinds of accidents or events cannot occur. Such measures include but are not limited to protective circuits and error prevention circuits for safe design, redundant design, and structural design.
- In the event that any or all SANYO Semiconductor products (including technical data, services) described or contained herein are controlled under any of applicable local export control laws and regulations, such products must not be exported without obtaining the export license from the authorities concerned in accordance with the above law.
- No part of this publication may be reproduced or transmitted in any form or by any means, electronic or mechanical, including photocopying and recording, or any information storage or retrieval system, or otherwise, without the prior written permission of SANYO Semiconductor Co., Ltd.
- Any and all information described or contained herein are subject to change without notice due to product/technology improvement, etc. When designing equipment, refer to the "Delivery Specification" for the SANYO Semiconductor product that you intend to use.
- Information (including circuit diagrams and circuit parameters) herein is for example only; it is not guaranteed for volume production. SANYO Semiconductor believes information herein is accurate and reliable, but no guarantees are made or implied regarding its use or any infringements of intellectual property rights or other rights of third parties.

This catalog provides information as of November, 2006. Specifications and information herein are subject to change without notice.