

BB-035

Baseboard
for TCMC-035

INFO The baseboard BB-035 allows to build a ready to use stepper driver unit using the TCMC-035 driver module. All important signal and power lines are accessible via screw terminals, the step and direction inputs are equipped with opto couplers. The integrated switch-mode regulator provides the required 5V supply voltage for the TCMC-035.

MAIN CHARACTERISTICS

- ELECTRICAL DATA**
 - 15V to 50V DC supply voltage
- INTERFACE**
 - optically de-coupled step/direction input (differential / optical)
 - SPI and analog inputs accessible via additional connector
- FEATURES**
 - 1 slot for TCMC-035 power driver
 - integrated 5V power supply
 - protection: overvoltage suppressor and inverse polarity
- OTHER**
 - RoHS compliant
 - size: 90 x 60 mm², 60 mm height

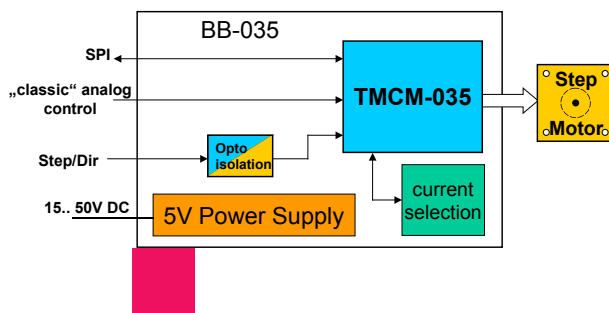

ORDER CODE	DESCRIPTION
BB-035	Baseboard for TCMC-035