



30N20

Preliminary

Power MOSFET

30A, 200V N-CHANNEL POWER MOSFET

DESCRIPTION

The UTC **30N20** is an N-channel mode Power FET, it uses UTC's advanced technology. This technology allows a minimum on-state resistance, superior switching performance. It also can withstand high energy pulse in the avalanche and commutation mode.

FEATURES

- * $R_{DS(ON)} < 75m\Omega$ @ $V_{GS}=10V, I_D=15A$
- * Low Gate Charge (Typical 60nC)
- * High Switching Speed

SYMBOL

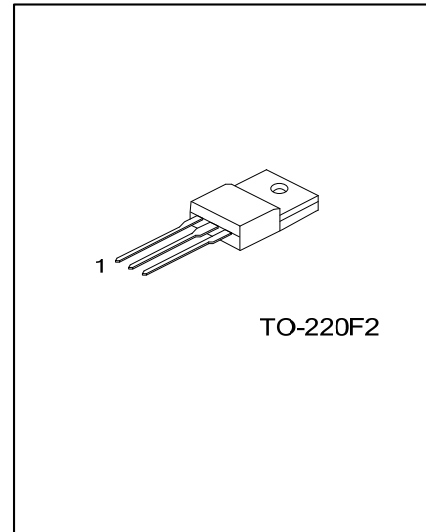
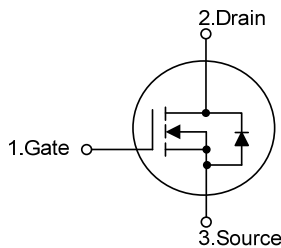

ORDERING INFORMATION

Ordering Number		Package	Pin Assignment			Packing
Lead Free	Halogen Free		1	2	3	
30N20L-TF2-T	30N20G-TF2-T	TO-220F2	G	D	S	Tube

Note: Pin Assignment: G: Gate D: Drain S: Source

<p>30N20L-TF2-T</p> <p>(1)Packing Type</p> <p>(2)Package Type</p> <p>(3)Lead Free</p>	<p>(1) T: Tube</p> <p>(2) TF2: TO-220F2</p> <p>(3) G: Halogen Free, L: Lead Free</p>
---------------------------------------------------------------------------------------	--------------------------------------------------------------------------------------

■ ABSOLUTE MAXIMUM RATINGS

PARAMETER		SYMBOL	RATINGS	UNIT
Drain-Source Voltage		V_{DSS}	200	V
Gate-Source Voltage		V_{GSS}	± 30	V
Drain Current	Continuous	I_D	30	A
	Pulsed	I_{DM}	124	A
Avalanche Current		I_{AR}	30	A
Avalanche Energy	Single Pulsed	E_{AS}	640	mJ
	Repetitive	E_{AR}	18	mJ
Power Dissipation		P_D	42	W
Junction Temperature		T_J	+150	$^{\circ}\text{C}$
Storage Temperature Range		T_{STG}	-55 ~ +150	$^{\circ}\text{C}$

Note: Absolute maximum ratings are those values beyond which the device could be permanently damaged. Absolute maximum ratings are stress ratings only and functional device operation is not implied.

■ ELECTRICAL CHARACTERISTICS

PARAMETER		SYMBOL	TEST CONDITIONS	MIN	TYP	MAX	UNIT
OFF CHARACTERISTICS							
Drain-Source Breakdown Voltage		BV_{DSS}	$I_D=250\mu\text{A}, V_{GS}=0\text{V}$	200			V
Drain-Source Leakage Current		I_{DSS}	$V_{DS}=200\text{V}$			1	μA
Gate-Source Leakage Current	Forward	I_{GSS}	$V_{GS}=+30\text{V}, V_{DS}=0\text{V}$			+100	nA
	Reverse		$V_{GS}=-30\text{V}, V_{DS}=0\text{V}$			-100	nA
ON CHARACTERISTICS							
Gate Threshold Voltage		$V_{GS(TH)}$	$I_D=250\mu\text{A}$	3		5	V
Static Drain-Source On-State Resistance		$R_{DS(ON)}$	$V_{GS}=10\text{V}, I_D=15\text{A}$			75	m Ω
DYNAMIC PARAMETERS							
Input Capacitance	C_{ISS}	$V_{GS}=0\text{V}, V_{DS}=25\text{V}, f=1\text{MHz}$			2400	3100	pF
Output Capacitance	C_{OSS}				430	560	pF
Reverse Transfer Capacitance	C_{RSS}				55	70	pF
SWITCHING PARAMETERS							
Total Gate Charge	Q_G	$V_{DD}=50\text{V}, V_{GS}=10\text{V}, I_D=1.3\text{A}$			60	78	nC
Gate to Source Charge	Q_{GS}				17		nC
Gate to Drain Charge	Q_{GD}				27		nC
Turn-ON Delay Time	$t_{D(ON)}$	$V_{DD}=30\text{V}, I_D=0.5\text{A}, R_G=25\Omega, V_{GS}=0\sim 10\text{V}$			40		ns
Rise Time	t_R				280		ns
Turn-OFF Delay Time	$t_{D(OFF)}$				125		ns
Fall-Time	t_F				115		ns
SOURCE- DRAIN DIODE RATINGS AND CHARACTERISTICS							
Maximum Body-Diode Continuous Current		I_S				30	A
Maximum Body-Diode Pulsed Current		I_{SM}				124	A
Drain-Source Diode Forward Voltage		V_{SD}	$I_S=30\text{A}, V_{GS}=0\text{V}$			1.5	V

UTC assumes no responsibility for equipment failures that result from using products at values that exceed, even momentarily, rated values (such as maximum ratings, operating condition ranges, or other parameters) listed in products specifications of any and all UTC products described or contained herein. UTC products are not designed for use in life support appliances, devices or systems where malfunction of these products can be reasonably expected to result in personal injury. Reproduction in whole or in part is prohibited without the prior written consent of the copyright owner. The information presented in this document does not form part of any quotation or contract, is believed to be accurate and reliable and may be changed without notice.