

HIGH SPEED CMOS LOGIC IC ELM7SH02xB 2-input NOR gate

■General description

ELM7SH02xB is CMOS 2-input NOR gate which is suitable for battery-operated devices because of its low voltage and ultra high speed operation. The low power consumption contributes to longer battery life, which allows long time operation of devices. The internal circuit which provides high noise immunity and stable output is composed of 3 stages, including buffered output.

■Features

- Same electrical characteristic and high speed operation as 74VHC series
- Low consumption current : $I_{dd}=1.0\mu\text{A}(\text{Max.})(T_{op}=25^{\circ}\text{C})$
- Wide power voltage range : 2.0V to 5.5V
- Wide input voltage range : $V_{ih}=5.5\text{V}(\text{Max.})(V_{dd}=0 \text{ to } 5.5\text{V})$
- High speed : $T_{pd}=2\text{ns}(\text{Typ.})(V_{dd}=5.0\text{V})$
- Small package : SOT-25, SC-70-5(SOT-353)
- Same function and pin configuration as ELM7SxxB

■Application

- Cell phones
- Digital cameras
- Portable electrical appliances like PDA, etc.
- Computers and peripherals
- Digital electrical appliances like LCD TV sets, DVD recorders/players, STB, etc.
- Modification inside print board, adjustment of timing, solution to noise
- Power voltage change from 5V to 3V

■Selection guide

ELM7SH02xB-EL

| Symbol | Function | |
|--------|------------------|-----------------------------------|
| a | Function | 02: 2-input NOR gate |
| b | Package | M: SOT-25 T : SC-70-5(SOT-353) |
| c | Product version | B |
| d | Taping direction | EL: Refer to PKG file |

ELM7SH 02 x B - EL
 $\begin{matrix} \uparrow & \uparrow & \uparrow & \uparrow \\ a & b & c & d \end{matrix}$

■Maximum absolute ratings

| Parameter | Symbol | Limit | Unit |
|--------------------------------|------------------------------------|------------------------------|------|
| Power supply voltage | V _{dd} | -0.5 to +6.0 | V |
| Input voltage | V _{in} | -0.5 to +6.0 | V |
| Output voltage | V _{out} | -0.5 to V _{dd} +0.5 | V |
| Input protection diode current | I _{ik} | -20 | mA |
| Output parasitic diode current | I _{ok} | ±20 | mA |
| Output current | I _{out} | ±25 | mA |
| VDD/GND current | I _{dd} , I _{gnd} | ±50 | mA |
| Power dissipation | P _d | 150 | mW |
| Storage temperature | T _{stg} | -65 to +150 | °C |

HIGH SPEED CMOS LOGIC IC ELM7SH02xB 2-input NOR gate

■Suggested operating condition

| Parameter | Symbol | Limit | | Unit |
|-----------------------|--------|--------------|----------|------|
| Power voltage | Vdd | 2.0 to 5.5 | | V |
| Input voltage | Vin | 0 to 5.5 | | V |
| Output voltage | Vout | 0 to Vdd | | V |
| Operating temperature | Top | -40 to +85 | | °C |
| High-input down-time | tr, tf | Vdd=3.3±0.3V | 0 to 200 | ns |
| | | Vdd=5.0±0.5V | 0 to 100 | |

■Pin configuration

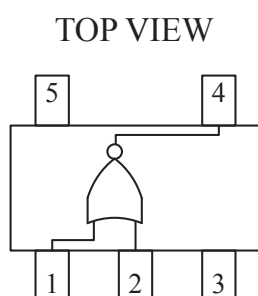

| Pin No. | Pin name |
|---------|----------|
| 1 | INB |
| 2 | INA |
| 3 | GND |
| 4 | OUTX |
| 5 | VDD |

| Input | | Output |
|-------|------|--------|
| INA | INB | OUTX |
| Low | Low | High |
| Low | High | Low |
| High | Low | Low |
| High | High | Low |

■DC electrical characteristics

| Parameter | Sym. | Vdd | Top=25°C | | | Top=-40 to +85°C | | Unit | Condition | |
|----------------|----------------|-----|----------|------|------|------------------|------|------|----------------------|----------------|
| | | | Min. | Typ. | Max. | Min. | Max. | | | |
| Input voltage | Vih | 2.0 | 1.50 | | | 1.50 | | V | | |
| | | 3.0 | 2.10 | | | 2.10 | | | | |
| | | 5.5 | 3.85 | | | 3.85 | | | | |
| | Vil | 2.0 | | | 0.50 | | 0.50 | V | | |
| | | 3.0 | | | 0.90 | | 0.90 | | | |
| | | 5.5 | | | 1.65 | | 1.65 | | | |
| Output voltage | Voh | 2.0 | 1.90 | 2.00 | | 1.90 | | V | Vin=Vil | Ioh=-50μA |
| | | 3.0 | 2.90 | 3.00 | | 2.90 | | | | |
| | | 4.5 | 4.40 | 4.50 | | 4.40 | | | | |
| | | 3.0 | 2.58 | | | 2.48 | | | | |
| | | 4.5 | 3.94 | | | 3.80 | | | | |
| | Vol | 2.0 | | | 0.10 | | 0.10 | V | Vin=Vil or Vih | Iol=50μA |
| | | 3.0 | | | 0.10 | | 0.10 | | | |
| | | 4.5 | | | 0.10 | | 0.10 | | | |
| | | 3.0 | | | 0.36 | | 0.44 | | | |
| | | 4.5 | | | 0.36 | | 0.44 | | | |
| | Input current | Iin | 5.5 | -0.1 | | 0.1 | -1.0 | 1.0 | μA | Vin=Vdd or GND |
| | Static current | Idd | 5.5 | | | 1.0 | | 10.0 | μA | Vin=Vdd or GND |

HIGH SPEED CMOS LOGIC IC ELM7SH02xB 2-input NOR gate

■ AC electrical characteristics

$t_r=t_f=3\text{ns}$

| Parameter | Sym. | Vdd | CL | Top=25°C | | | Top=-40 to +85°C | | Unit | Condition |
|---------------------------|------|---------|----|----------|------|------|------------------|------|------|-----------------------|
| | | | | Min. | Typ. | Max. | Min. | Max. | | |
| Propagation delay-time | tPLH | 3.3±0.3 | 15 | | 3.9 | 7.9 | 1.0 | 9.5 | ns | Refer to test circuit |
| | tPHL | | | | 3.5 | 7.9 | 1.0 | 9.5 | | |
| | tPLH | 3.3±0.3 | 50 | | 5.5 | 11.4 | 1.0 | 13.0 | | |
| | tPHL | | | | 4.9 | 11.4 | 1.0 | 13.0 | | |
| | tPLH | 5.0±0.5 | 15 | | 2.7 | 5.5 | 1.0 | 6.5 | | |
| | tPHL | | | | 2.6 | 5.5 | 1.0 | 6.5 | | |
| | tPLH | 5.0±0.5 | 50 | | 3.9 | 7.5 | 1.0 | 8.5 | | |
| | tPHL | | | | 3.6 | 7.5 | 1.0 | 8.5 | | |
| Input capacity | Cin | 5.0 | | | 4.0 | 10.0 | | 10.0 | pF | Vin=Vdd or GND |
| Equivalent inner capacity | Cpd | | | | 9.7 | | | | pF | f=1MHz |

* Cpd is IC's inner equivalent capacity which is calculated from non-loaded operating current consumption referred to test circuit. Averaged operating current consumption at non load is calculated as following formula: $I_{dd(opr)}=Cpd \cdot Vdd \cdot fin+I_{dd}$

■ Test circuit

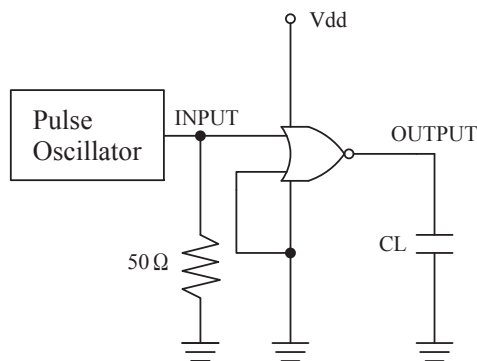

■ Measured wave pattern

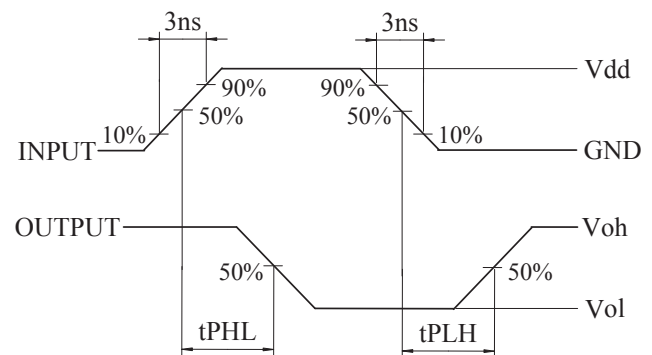

* Output should be opened when measuring current consumption.

■ Marking

SC-70-5

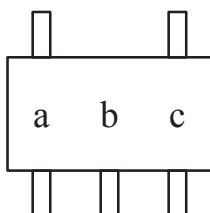

SOT-25

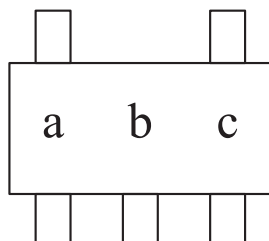

| Sym. | Mark | Content |
|------|----------------------------|---------------|
| a | F | ELM7SH series |
| b | 3 | ELM7SH02xB |
| c | A to Z (except I, O, X) | Lot No. |