

**PLEASE CHECK WWW.MOLEX.COM FOR LATEST PART INFORMATION**

**Part Number:** [0850010490](#)  
**Status:** **Active**  
**Overview:** [din\\_41612](#)  
**Description:** 2.54mm (.100") Pitch DIN 41612 B Style Male Header, PCT, Right Angle, Through Hole, 0.30µm (12µ") Selective Gold (Au) Plating, 64 Circuits, without Mounting Clips, No Flux Proof

**Documents:**

[Drawing \(PDF\)](#) [RoHS Certificate of Compliance \(PDF\)](#)  
[Product Specification PS-85003-0001 \(PDF\)](#)

**Agency Certification**

CSA LR19980  
 UL E29179

**General**

Product Family Backplane Connectors  
 Series [85001](#)  
 Application Backplane  
 Comments No Mounting Clips. No Flux Proof. 3.0mm(.118") 2 First-Mate-Last- Break Contacts at Z.  
 Component Type PCB Header  
 Overview [din\\_41612](#)  
 Product Name IEC 603-2/DIN 41612  
 Style B

**Physical**

Circuits (Loaded) 64  
 Circuits (maximum) 64  
 Circuits Detail Contact Positions: A:a2-a31; B:b1-b32; Z:a1,a32  
 Color - Resin Natural  
 Durability (mating cycles max) 400  
 First Mate / Last Break Yes  
 Flammability 94V-0  
 Guide to Mating Part No  
 Keying to Mating Part Yes  
 Material - Metal Brass  
 Material - Plating Mating Gold  
 Material - Plating Termination Tin  
 Material - Resin Polyester  
 Number of Columns 16  
 Number of Pairs Open Pin Field  
 Number of Rows 2  
 Orientation Right Angle  
 PC Tail Length (in) 0.154 In  
 PC Tail Length (mm) 3.90 mm  
 PCB Locator No  
 PCB Retention Yes  
 Packaging Type Carton  
 Pitch - Mating Interface (in) 0.100 In  
 Pitch - Mating Interface (mm) 2.54 mm  
 Pitch - Term. Interface (in) 0.100 In  
 Pitch - Term. Interface (mm) 2.54 mm  
 Plating min: Mating (µin) 24  
 Plating min: Mating (µm) 0.60  
 Plating min: Termination (µin) 98

**EU RoHS** **China RoHS**

**Compliance Status**

**Not Reviewed**

**REACH SVHC**

**Not Reviewed**

**Halogen-Free**

**Status**

**Not Reviewed**

**Need more information on product environmental compliance?**

Email [productcompliance@molex.com](mailto:productcompliance@molex.com)  
 For a multiple part number RoHS Certificate of Compliance, [click here](#)

Please visit the [Contact Us](#) section for any non-product compliance questions.

**Search Parts in this Series**

[85001Series](#)

Plating min: Termination ( $\mu\text{m}$ )	2.5
Polarized to PCB	Yes
Stackable	No
Surface Mount Compatible (SMC)	No
Temperature Range - Operating	-55°C to +125°C
Termination Interface: Style	Through Hole

### **Electrical**

Current - Maximum per Contact	1A
Data Rate	622.0 Mbps
Voltage - Maximum	250V AC (RMS)

### **Material Info**

### **Reference - Drawing Numbers**

Packaging Specification	PK-36507-001
Product Specification	PS-85003-0001
Sales Drawing	SDA-85001-0001, SDA-85001-0490

This document was generated on 05/17/2010

**PLEASE CHECK [WWW.MOLEX.COM](http://WWW.MOLEX.COM) FOR LATEST PART INFORMATION**

PART NO.  
DWG. NO.

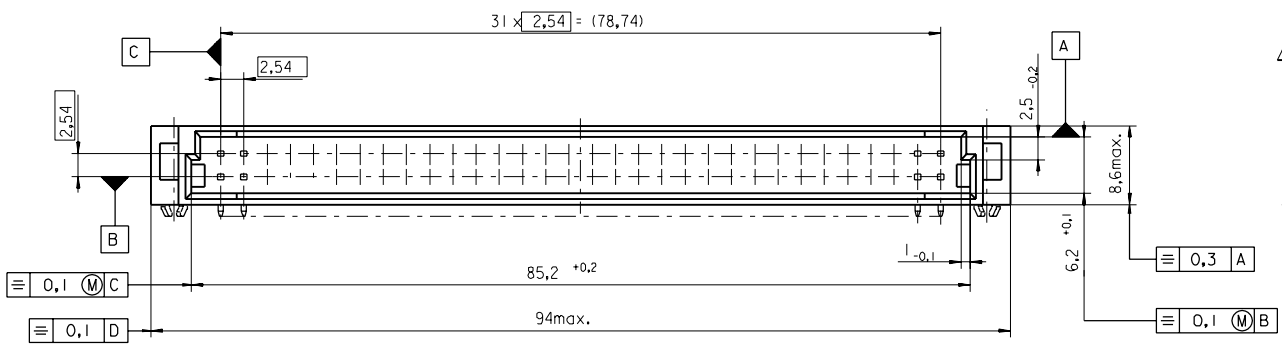

View X 5:1 View Y 5:1

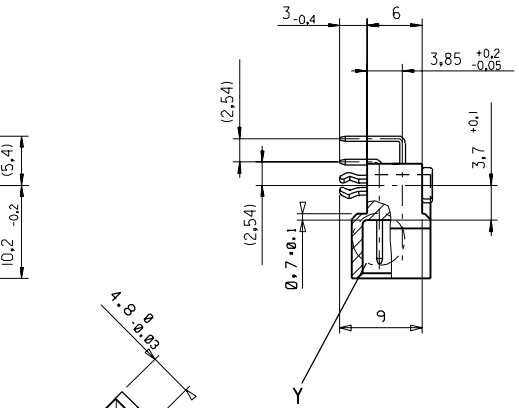
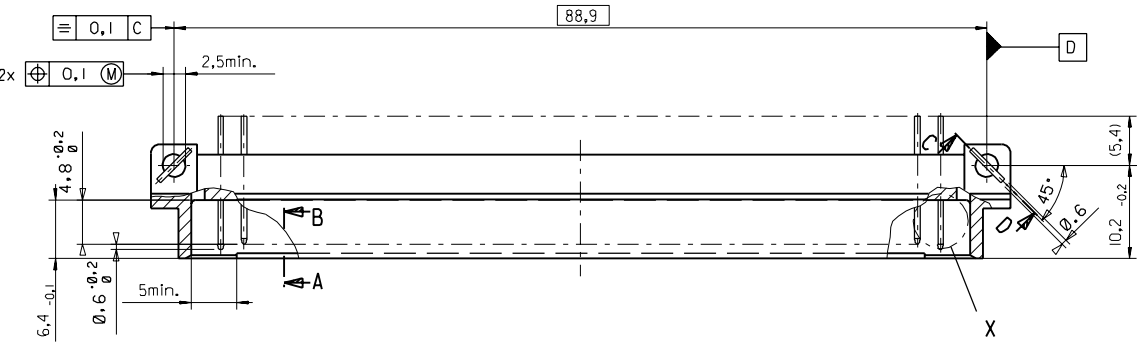
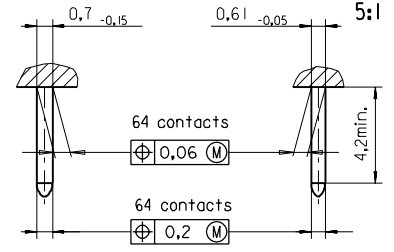

Section C - D

Section A - B 5:1

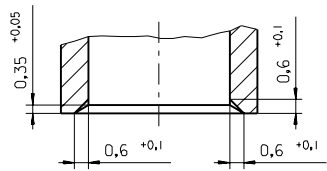

FIRST ANGLE PROJECTION		REVISE ONLY ON CAD SYSTEM		SH.	REV.
first release see ECN No. 1887	REVISIONS FOR PREVIOUS REVISIONS SEE MRI LIST	UNLESS OTHERWISE SPECIFIED TOLERANCES: ANGULAR ±2°	DRWG BY SIGN Ca	CAD/CAM PROJECT NAME 85001000 811	
		INCH METRIC	CHK'D BY SIGN KN	THIS DRAWING CONTAINS INFORMATION THAT IS PROPRIETARY TO MOLEX INC. & SHOULD NOT BE USED WITHOUT WRITTEN PERMISSION	
A	LTR	3 PLACE ± . ±	APP'D BY SIGN	TITLE 64 pos. Male connector acc. DIN 41612 style B Dimensions	
		2 PLACE ± . ±	SCALE 2:1	SHEET NO. DATE 1 OF 95/06/06	
		1 PLACE ± . ±		MOLEX MOLEX EUROPE	
		DRAFT WHERE APPLICABLE MUST REMAIN WITHIN DIMENSIONS		SHEET NO. DATE 1 OF 95/06/06	
		DESIGN DIMENSION <input checked="" type="checkbox"/> MM		PART NO. DWG NO. SIZE	
		EQUIVALENT DIMENSION <input type="checkbox"/> MM		SDA-85001-0001 B	
		IF TWO DIMENSIONS ARE SHOWN THE UPPER IS THE DESIGN DIMENSION, LOWER IS SECONDARY			

