



**256 Bit**

**X24C44**

**16 x 16 Bit**

**Serial Nonvolatile Static RAM**

**FEATURES**

- **Advanced CMOS Version of Xicor's X2444**
- **16 x 16 Organization**
- **Single 5 Volt Supply**
- **Ideal for use with Single Chip Microcomputers**
  - Static Timing
  - Minimum I/O Interface
  - Serial Port Compatible (COPS™, 8051)
  - Easily Interfaced to Microcontroller Ports
- **Software and Hardware Control of Nonvolatile Functions**
- **Auto Recall on Power-Up**
- **TTL and CMOS Compatible**
- **Low Power Dissipation**
  - Active Current: 10mA Maximum
  - Standby Current: 50µA Maximum
- **8-Lead PDIP, Cerdip, and 8-Lead SOIC Packages**
- **High Reliability**
  - Store Cycles: 1,000,000
  - Data Retention: 100 Years

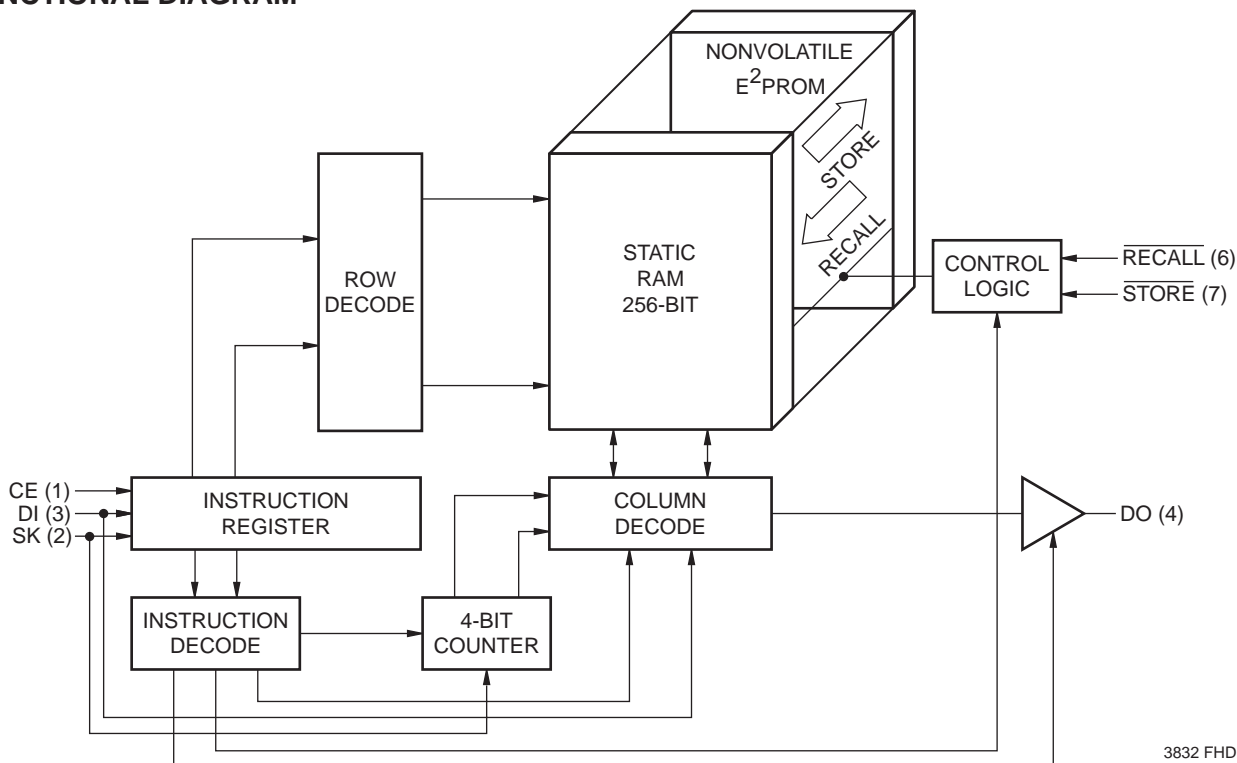
**DESCRIPTION**

The Xicor X24C44 is a serial 256 bit NOVRAM featuring a static RAM configured 16 x 16, overlaid bit-by-bit with a nonvolatile E<sup>2</sup>PROM array. The X24C44 is fabricated with Xicor's Advanced CMOS Floating Gate technology.

The Xicor NOVRAM design allows data to be transferred between the two memory arrays by means of software commands or external hardware inputs. A store operation (RAM data to E<sup>2</sup>PROM) is completed in 5ms or less and a recall operation (E<sup>2</sup>PROM data to RAM) is completed in 2µs or less.

Xicor NOVRAMs are designed for unlimited write operations to RAM, either from the host or recalls from E<sup>2</sup>PROM and a minimum 1,000,000 store operations. Inherent data retention is specified to be greater than 100 years.

**FUNCTIONAL DIAGRAM**



3832 FHD F01

# X24C44

## PIN DESCRIPTIONS

### Chip Enable (CE)

The Chip Enable input must be HIGH to enable all read/write operations. CE must remain HIGH following a Read or Write command until the data transfer is complete. CE LOW places the X24C44 in the low power standby mode and resets the instruction register. Therefore, CE must be brought LOW after the completion of an operation in order to reset the instruction register in preparation for the next command.

### Serial Clock (SK)

The Serial Clock input is used to clock all data into and out of the device.

### Data In (DI)

Data In is the serial data input.

### Data Out (DO)

Data Out is the serial data output. It is in the high impedance state except during data output cycles in response to a READ instruction.

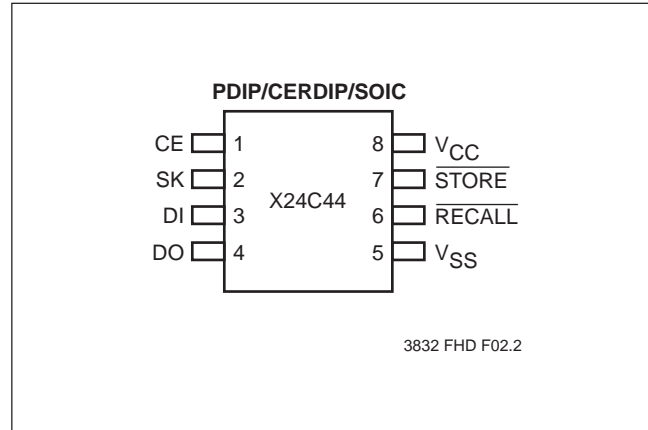
### $\overline{\text{STORE}}$

$\overline{\text{STORE}}$  LOW will initiate an internal transfer of data from RAM to the E<sup>2</sup>PROM array.

### $\overline{\text{RECALL}}$

$\overline{\text{RECALL}}$  LOW will initiate an internal transfer of data from E<sup>2</sup>PROM to the RAM array.

## PIN CONFIGURATION



## PIN NAMES

| Symbol                     | Description     |
|----------------------------|-----------------|
| CE                         | Chip Enable     |
| SK                         | Serial Clock    |
| DI                         | Serial Data In  |
| DO                         | Serial Data Out |
| $\overline{\text{RECALL}}$ | Recall Input    |
| $\overline{\text{STORE}}$  | Store Input     |
| V <sub>CC</sub>            | +5V             |
| V <sub>SS</sub>            | Ground          |

3832 PGM T01

# X24C44

## DEVICE OPERATION

The X24C44 contains an 8-bit instruction register. It is accessed via the DI input, with data being clocked in on the rising edge of SK. CE must be HIGH during the entire data transfer operation.

Table 1. contains a list of the instructions and their operation codes. The most significant bit (MSB) of all instructions is a logic one (HIGH), bits 6 through 3 are either RAM address bits (A) or don't cares (X) and bits 2 through 0 are the operation codes. The X24C44 requires the instruction to be shifted in with the MSB first.

After CE is HIGH, the X24C44 will not begin to interpret the data stream until a logic "1" has been shifted in on DI. Therefore, CE may be brought HIGH with SK running and DI LOW. DI must then go HIGH to indicate the start condition of an instruction before the X24C44 will begin any action.

In addition, the SK clock is totally static. The user can completely stop the clock and data shifting will be stopped. Restarting the clock will resume shifting of data.

### RCL and $\overline{\text{RECALL}}$

Either a software RCL instruction or a LOW on the  $\overline{\text{RECALL}}$  input will initiate a transfer of E<sup>2</sup>PROM data into RAM. This software or hardware recall operation sets an internal "previous recall" latch. This latch is reset upon power-up and must be intentionally set by the user to enable any write or store operations. Although a recall operation is performed upon power-up, the previous recall latch is not set by this operation.

### WRDS and WREN

Internally the X24C44 contains a "write enable" latch. This latch must be set for either writes to the RAM or store

operations to the E<sup>2</sup>PROM. The WREN instruction sets the latch and the WRDS instruction resets the latch, disabling both RAM writes and E<sup>2</sup>PROM stores, effectively protecting the nonvolatile data from corruption. The write enable latch is automatically reset on power-up.

### STO and $\overline{\text{STORE}}$

Either the software STO instruction or a LOW on the  $\overline{\text{STORE}}$  input will initiate a transfer of data from RAM to E<sup>2</sup>PROM. In order to safeguard against unwanted store operations, the following conditions must be true:

- STO instruction issued or  $\overline{\text{STORE}}$  input is LOW.
- The internal "write enable" latch must be set (WREN instruction issued).
- The "previous recall" latch must be set (either a software or hardware recall operation).

Once the store cycle is initiated, all other device functions are inhibited. Upon completion of the store cycle, the write enable latch is reset. Refer to Figure 4 for a state diagram description of enabling/disabling conditions for store operations.

### WRITE

The WRITE instruction contains the 4-bit address of the word to be written. The write instruction is immediately followed by the 16-bit word to be written. CE must remain HIGH during the entire operation. CE must go LOW before the next rising edge of SK. If CE is brought LOW prematurely (after the instruction but before 16 bits of data are transferred), the instruction register will be reset and the data that was shifted-in will be written to RAM.

If CE is kept HIGH for more than 24 SK clock cycles (8-bit instruction plus 16-bit data), the data already shifted-in will be overwritten.

**Table 1. Instruction Set**

| Instruction      | Format, I <sub>2</sub> I <sub>1</sub> I <sub>0</sub> | Operation   |
|------------------|--|---|
| WRDS (Figure 3)  | 1XXXX000   | Reset Write Enable Latch (Disables Writes and Stores) |
| STO (Figure 3)   | 1XXXX001   | Store RAM Data in E <sup>2</sup> PROM                 |
| Reserved         | 1XXXX010   | N/A   |
| WRITE (Figure 2) | 1AAAA011   | Write Data into RAM Address AAAA                      |
| WREN (Figure 3)  | 1XXXX100   | Set Write Enable Latch (Enables Writes and Stores)    |
| RCL (Figure 3)   | 1XXXX101   | Recall E <sup>2</sup> PROM Data into RAM              |
| READ (Figure 1)  | 1AAAA11X   | Read Data from RAM Address AAAA                       |

X = Don't Care  
A = Address

3832 PGM T13

# X24C44

---

## READ

The READ instruction contains the 4-bit address of the word to be accessed. Unlike the other six instructions, I<sub>0</sub> of the instruction word is a “don’t care”. This provides two advantages. In a design that ties both DI and DO together, the absence of an eighth bit in the instruction allows the host time to convert an I/O line from an output to an input. Secondly, it allows for valid data output during the ninth SK clock cycle.

DO, the first bit output during a read operation, is truncated. That is, it is internally clocked by the falling edge of the eighth SK clock; whereas, all succeeding bits are clocked by the rising edge of SK (refer to Read Cycle Diagram).

## LOW POWER MODE

When CE is LOW, non-critical internal devices are powered-down, placing the device in the standby power mode, thereby minimizing power consumption.

## SLEEP

Because the X24C44 is a low power CMOS device, the SLEEP instruction implemented on the first generation NMOS device has been deleted. For systems converting from the X2444 to the X24C44 the software need not be changed; the instruction will be ignored.

## WRITE PROTECTION

The X24C44 provides two software write protection mechanisms to prevent inadvertent stores of unknown data.

### Power-Up Condition

Upon power-up the “write enable” latch is in the reset state, disabling any store operation.

### Unknown Data Store

The “previous recall” latch must be set after power-up. It may be set only by performing a software or hardware recall operation, which assures that data in all RAM locations is valid.

## SYSTEM CONSIDERATIONS

### Power-Up Recall

The X24C44 performs a power-up recall that transfers the E<sup>2</sup>PROM contents to the RAM array. Although the data may be read from the RAM array, this recall does not set the “previous recall” latch. During this power-up recall operation, all commands are ignored. Therefore, the host should delay any operations with the X24C44 a minimum of t<sub>PUR</sub> after V<sub>CC</sub> is stable.

### Power-Down Data Protection

Because the X24C44 is a 5V only nonvolatile memory device it may be susceptible to inadvertent stores to the E<sup>2</sup>PROM array during power-down cycles. Power-up cycles are not a problem because the “previous recall” latch and “write enable” latch are reset, preventing any possible corruption of E<sup>2</sup>PROM data.

### Software Power-Down Protection

If the  $\overline{\text{STORE}}$  and  $\overline{\text{RECALL}}$  pins are tied to V<sub>CC</sub> through a pull-up resistor and only software operations are performed to initiate stores, there is little likelihood of an inadvertent store. However, if these two lines are under microprocessor control, positive action should be employed to negate the possibility of these control lines bouncing and generating an unwanted store. The safest method is to issue the WRDS command after a write sequence and also following store operations. Note: an internal store may take up to 5ms; therefore, the host microprocessor should delay 5ms after initiating the store prior to issuing the WRDS command.

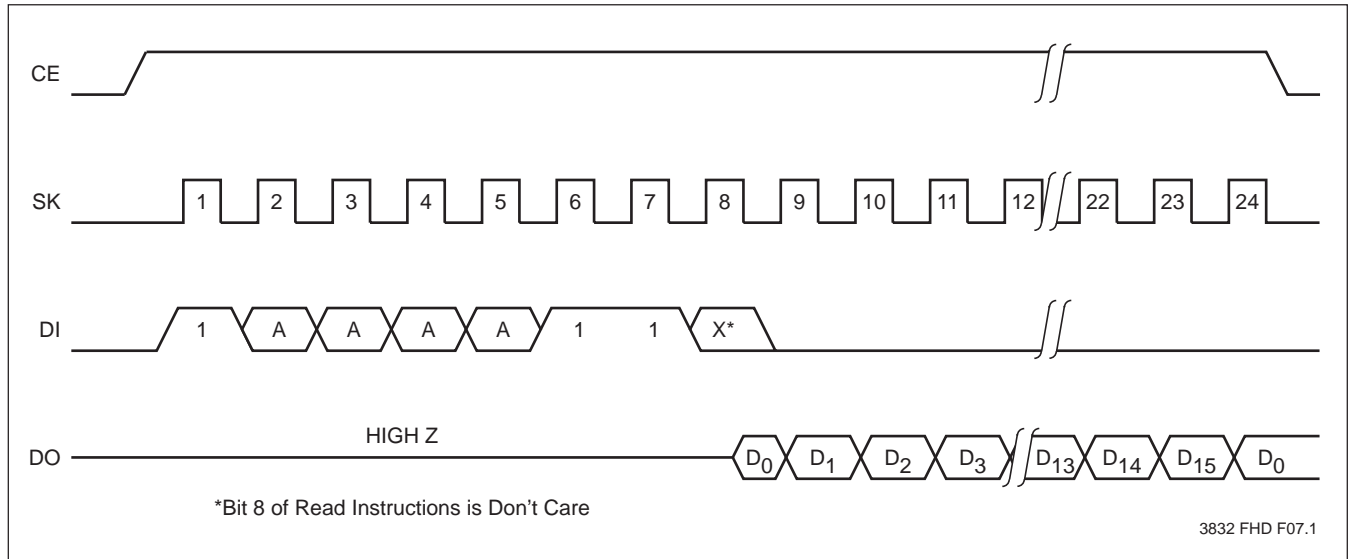
### Hardware Power-Down Protection

(when the “write enable” latch and “previous recall” latch are not in the reset state):

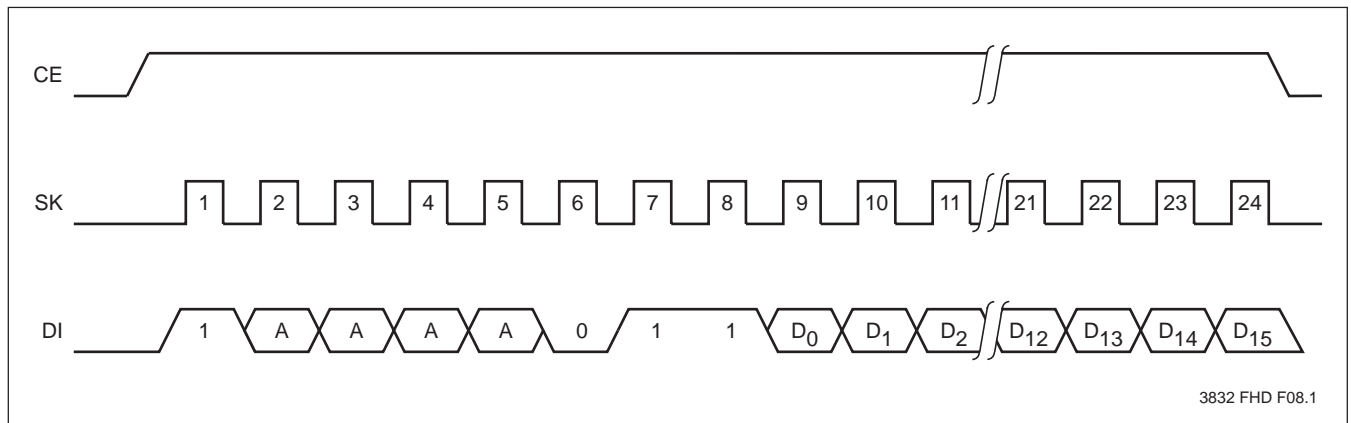
Holding either  $\overline{\text{RECALL}}$  LOW, CE LOW or  $\overline{\text{STORE}}$  HIGH during power-down will prevent an inadvertent store.

# X24C44

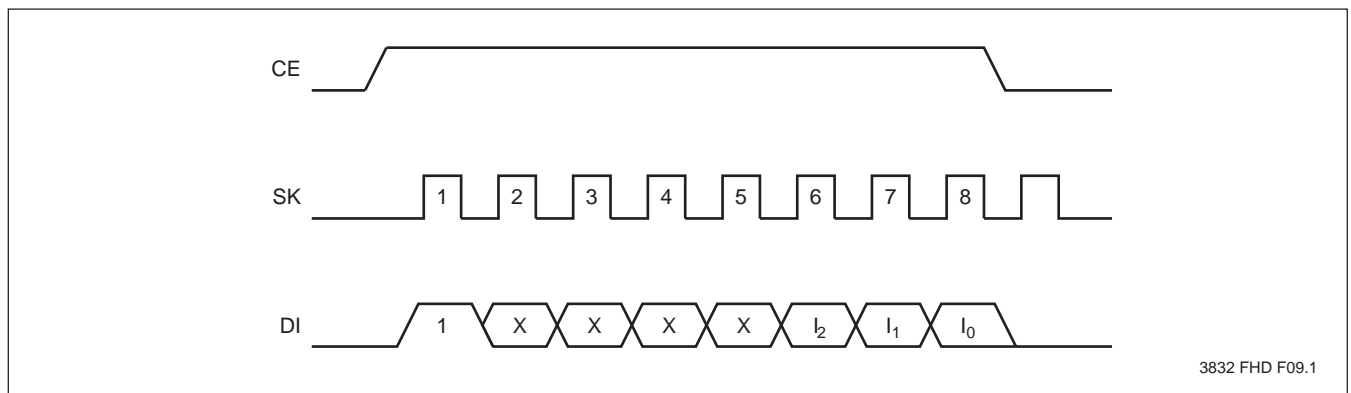
**Figure 1. RAM Read**



**Figure 2. RAM Write**

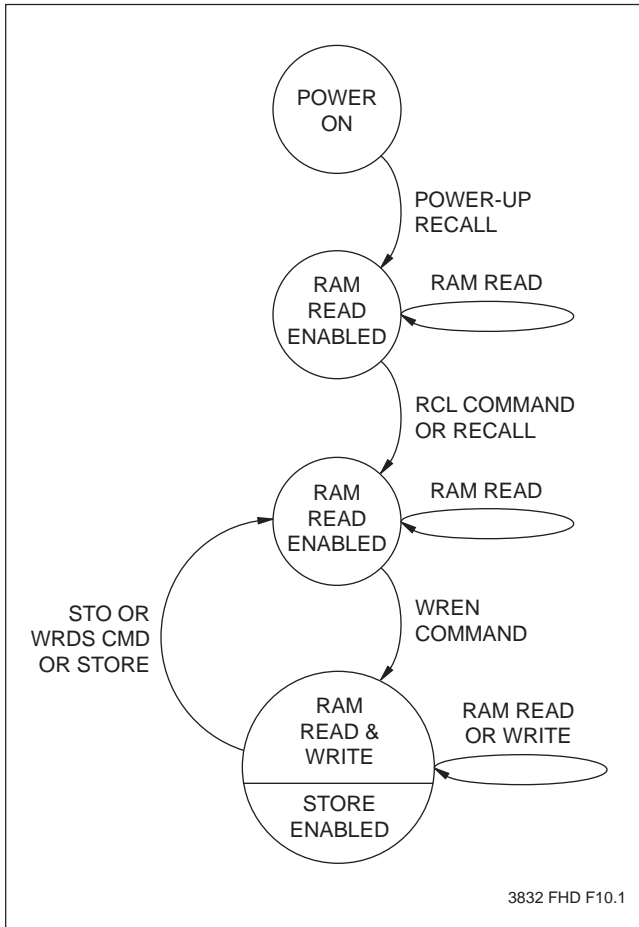


**Figure 3. Non-Data Operations**



# X24C44

Figure 4. X24C44 State Diagram



# X24C44

## ABSOLUTE MAXIMUM RATINGS\*

|  |                 |
|--|-----------------|
| Temperature under Bias .....                         | -65°C to +135°C |
| Storage Temperature .....                            | -65°C to +150°C |
| Voltage on any Pin with<br>Respect to $V_{SS}$ ..... | -1V to +7V      |
| D.C. Output Current .....                            | 5mA             |
| Lead Temperature<br>(Soldering, 10 seconds) .....    | 300°C           |

## \*COMMENT

Stresses above those listed under “Absolute Maximum Ratings” may cause permanent damage to the device. This is a stress rating only and the functional operation of the device at these or any other conditions above those indicated in the operational sections of this specification is not implied. Exposure to absolute maximum rating conditions for extended periods may affect device reliability.

## RECOMMENDED OPERATING CONDITIONS

| Temperature | Min.  | Max.   |
|-------------|-------|--------|
| Commercial  | 0°C   | +70°C  |
| Industrial  | -40°C | +85°C  |
| Military    | -55°C | +125°C |

3832 PGM T02.1

| Supply Voltage | Limits  |
|----------------|---------|
| X24C44         | 5V ±10% |

3832 PGM T03.1

## D.C. OPERATING CHARACTERISTICS (Over recommended operating conditions unless otherwise specified.)

| Symbol         | Parameter                              | Limits |              | Units | Test Conditions  |
|----------------|--|--------|--------------|-------|--|
|                |  | Min.   | Max.         |       |  |
| $I_{CC}$       | $V_{CC}$ Supply Current (TTL Inputs)   |        | 10           | mA    | SK = 0.4V/2.4V Levels @ 1MHz, DO = Open, All Other Inputs = $V_{IH}$ |
| $I_{SB1}$      | $V_{CC}$ Standby Current (TTL Inputs)  |        | 1            | mA    | DO = Open, CE = $V_{IL}$ , All Other Inputs = $V_{IH}$               |
| $I_{SB2}$      | $V_{CC}$ Standby Current (CMOS Inputs) |        | 50           | µA    | DO = Open, CE = $V_{SS}$ All Other Inputs = $V_{CC} - 0.3V$          |
| $I_{LI}$       | Input Load Current                     |        | 10           | µA    | $V_{IN} = V_{SS}$ to $V_{CC}$  |
| $I_{LO}$       | Output Leakage Current                 |        | 10           | µA    | $V_{OUT} = V_{SS}$ to $V_{CC}$                                       |
| $V_{IL}^{(1)}$ | Input LOW Voltage                      | -1     | 0.8          | V     |  |
| $V_{IH}^{(1)}$ | Input HIGH Voltage                     | 2      | $V_{CC} + 1$ | V     |  |
| $V_{OL}$       | Output LOW Voltage                     |        | 0.4          | V     | $I_{OL} = 4.2mA$   |
| $V_{OH}$       | Output HIGH Voltage                    | 2.4    |              | V     | $I_{OH} = -2mA$  |

3832 PGM T04.3

## ENDURANCE AND DATA RETENTION

| Parameter      | Min.      | Units                |
|----------------|-----------|----------------------|
| Endurance      | 100,000   | Data Changes Per Bit |
| Store Cycles   | 1,000,000 | Store Cycles         |
| Data Retention | 100       | Years                |

3832 PGM T05

## CAPACITANCE $T_A = +25^\circ C$ , $f = 1MHz$ , $V_{CC} = 5V$

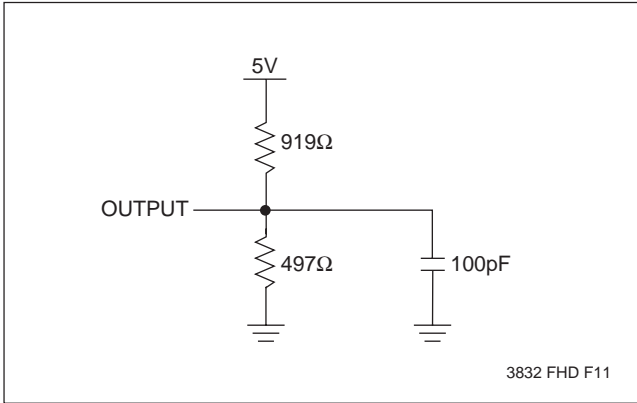
| Symbol          | Parameter          | Max. | Units | Test Conditions |
|-----------------|--------------------|------|-------|-----------------|
| $C_{OUT}^{(2)}$ | Output Capacitance | 8    | pF    | $V_{OUT} = 0V$  |
| $C_{IN}^{(2)}$  | Input Capacitance  | 6    | pF    | $V_{IN} = 0V$   |

3832 PGM T06.1

**Notes:** (1)  $V_{IL}$  min. and  $V_{IH}$  max. are for reference only and are not tested.  
(2) This parameter is periodically sampled and not 100% tested.

# X24C44

## EQUIVALENT A.C. LOAD CIRCUIT



## A.C. CONDITIONS OF TEST

|                                |          |
|--------------------------------|----------|
| Input Pulse Levels             | 0V to 3V |
| Input Rise and Fall Times      | 10ns     |
| Input and Output Timing Levels | 1.5V     |

3832 PGM T07.1

## A.C. CHARACTERISTICS (Over the recommended operating conditions unless otherwise specified.)

### Read and Write Cycle Limits

| Symbol         | Parameter                    | Min. | Max. | Units |
|----------------|------------------------------|------|------|-------|
| $F_{SK}^{(3)}$ | SK Frequency                 |      | 1    | MHz   |
| $t_{SKH}$      | SK Positive Pulse Width      | 400  |      | ns    |
| $t_{SKL}$      | SK Negative Pulse Width      | 400  |      | ns    |
| $t_{DS}$       | Data Setup Time              | 400  |      | ns    |
| $t_{DH}$       | Data Hold Time               | 80   |      | ns    |
| $t_{PD1}$      | SK to Data Bit 0 Valid       |      | 375  | ns    |
| $t_{PD}$       | SK to Data Valid             |      | 375  | ns    |
| $t_z$          | Chip Enable to Output High Z |      | 1    | μs    |
| $t_{CES}$      | Chip Enable Setup            | 800  |      | ns    |
| $t_{CEH}$      | Chip Enable Hold             | 350  |      | ns    |
| $t_{CDS}$      | Chip Deselect                | 800  |      | ns    |

3832 PGM T08.1

### POWER-UP TIMING

| Symbol          | Parameter                            | Max. | Units |
|-----------------|--------------------------------------|------|-------|
| $t_{PUR}^{(4)}$ | Power-up to Read Operation           | 200  | μs    |
| $t_{PUW}^{(4)}$ | Power-up to Write or Store Operation | 5    | ms    |

3832 PGM T09

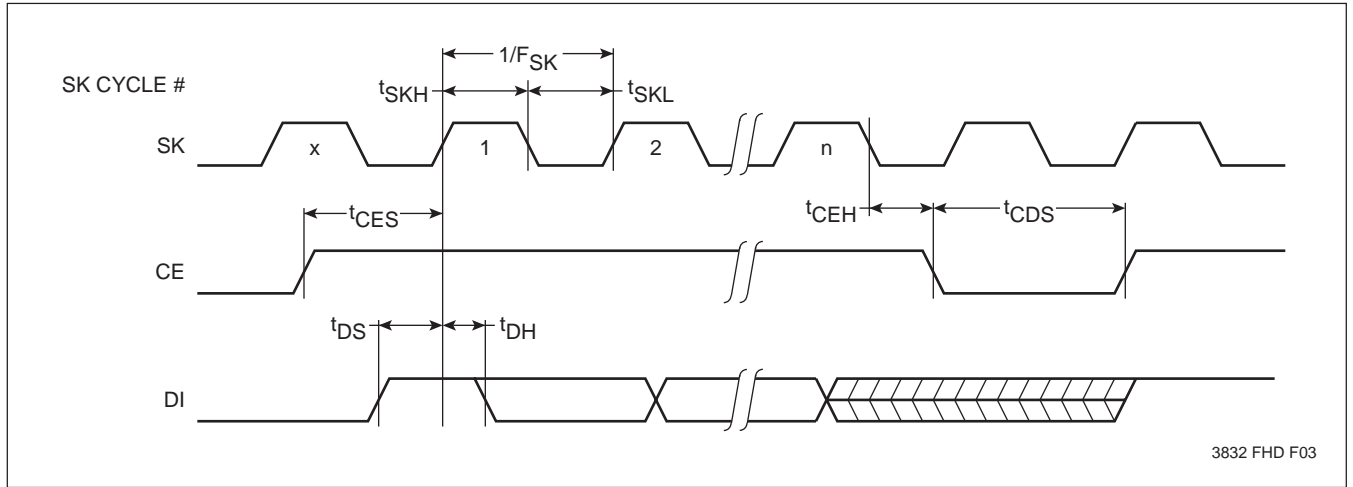
**Notes:** (3) SK rise and fall times must be less than 50ns.

(4)  $t_{PUR}$  and  $t_{PUW}$  are the delays required from the time  $V_{CC}$  is stable until the specified operation can be initiated. These parameters are periodically sampled and not 100% tested.

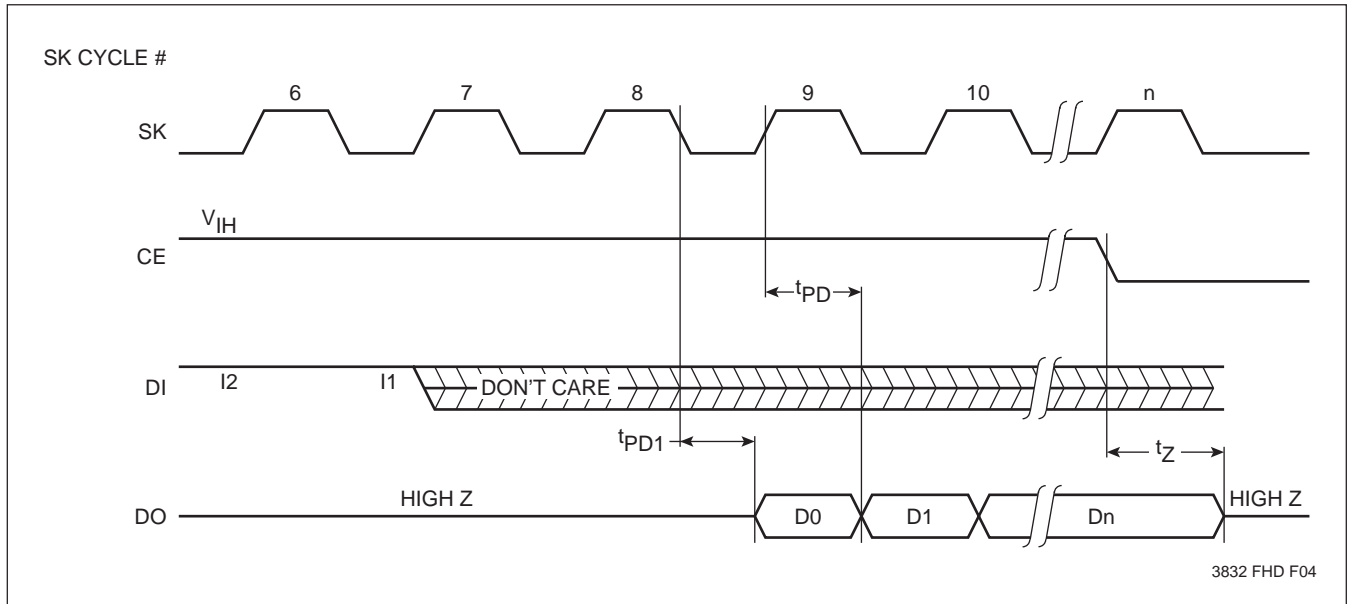


# X24C44

## Write Cycle



## Read Cycle



# X24C44

## NONVOLATILE OPERATIONS

| Operation       | $\overline{\text{STORE}}$ | $\overline{\text{RECALL}}$ | Software Instruction | Write Enable Latch State | Previous Recall Latch State |
|-----------------|---------------------------|----------------------------|----------------------|--------------------------|-----------------------------|
| Hardware Recall | 1                         | 0                          | NOP <sup>(5)</sup>   | X                        | X                           |
| Software Recall | 1                         | 1                          | RCL                  | X                        | X                           |
| Hardware Store  | 0                         | 1                          | NOP <sup>(5)</sup>   | SET                      | SET                         |
| Software Store  | 1                         | 1                          | STO                  | SET                      | SET                         |

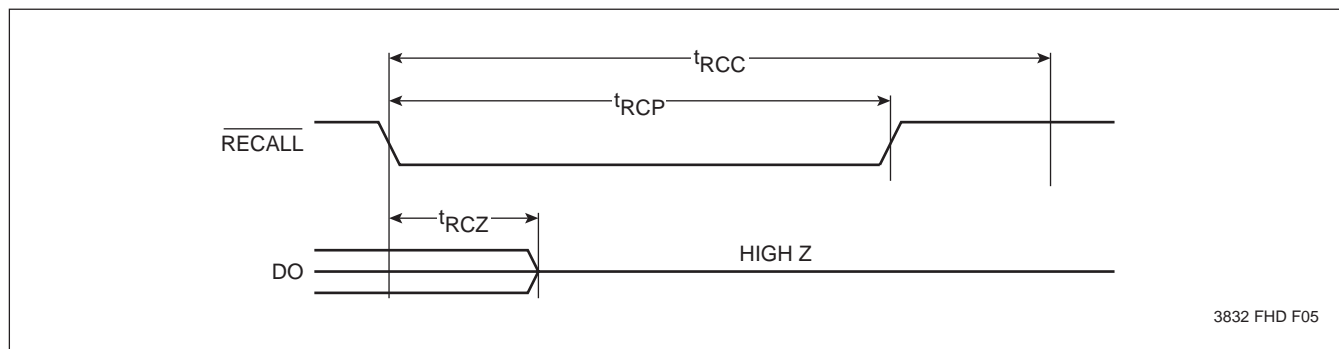
3832 PGM T10

## ARRAY RECALL LIMITS

| Symbol           | Parameter                         | Min. | Max. | Units         |
|------------------|-----------------------------------|------|------|---------------|
| $t_{\text{RCC}}$ | Recall Cycle Time                 | 2    |      | $\mu\text{s}$ |
| $t_{\text{RCP}}$ | Recall Pulse Width <sup>(6)</sup> | 500  |      | ns            |
| $t_{\text{RCZ}}$ | Recall to Output in High Z        |      | 500  | ns            |

3832 PGM T11

## Recall Timing



3832 FHD F05

- Notes:** (5) NOP designates when the X24C44 is not currently executing an instruction.  
 (6) Recall rise time must be  $<10\mu\text{s}$ .

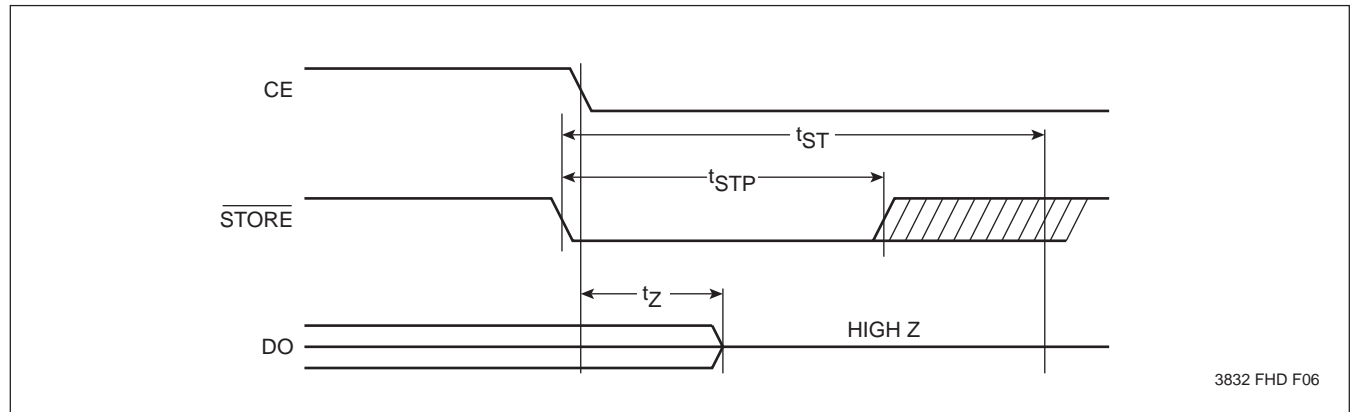
# X24C44

## STORE CYCLE LIMITS

| Symbol    | Parameter              | Min. | Typ.(7) | Max. | Units   |
|-----------|------------------------|------|---------|------|---------|
| $t_{ST}$  | Store Time             |      | 2       | 5    | ms      |
| $t_{STP}$ | Store Pulse Width      | 200  |         |      | ns      |
| $t_z$     | CE to Output in High Z |      |         | 1    | $\mu$ s |
| $V_{CC}$  | Store Inhibit          |      | 3       |      | V       |

3832 PGM T12

## Store Timing



3832 FHD F06

**Note:** (7) Typical values are for  $T_A = 25^\circ\text{C}$  and nominal supply voltage.

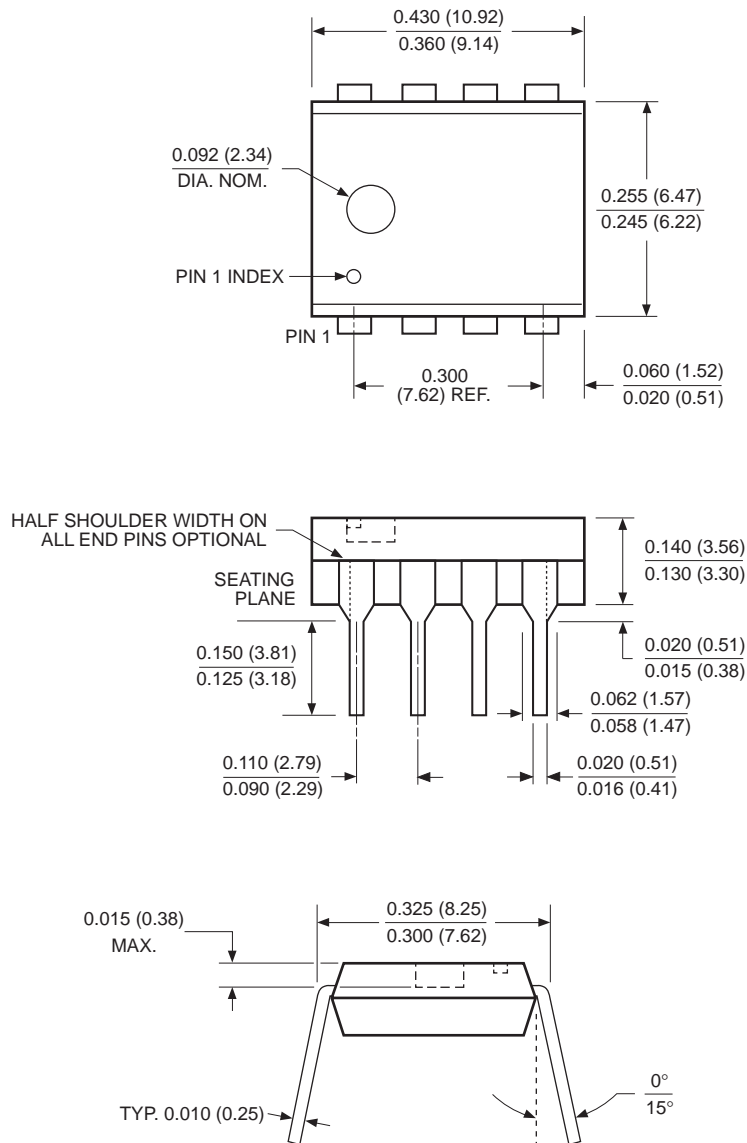
## SYMBOL TABLE

| WAVEFORM | INPUTS                      | OUTPUTS                       |
|----------|-----------------------------|-------------------------------|
|          | Must be steady              | Will be steady                |
|          | May change from LOW to HIGH | Will change from LOW to HIGH  |
|          | May change from HIGH to LOW | Will change from HIGH to LOW  |
|          | Don't Care: Changes Allowed | Changing: State Not Known     |
|          | N/A                         | Center Line is High Impedance |

# X24C44

## PACKAGING INFORMATION

### 8-LEAD PLASTIC DUAL IN-LINE PACKAGE TYPE P



NOTE: ALL DIMENSIONS IN INCHES (IN PARENTHESES IN MILLIMETERS)

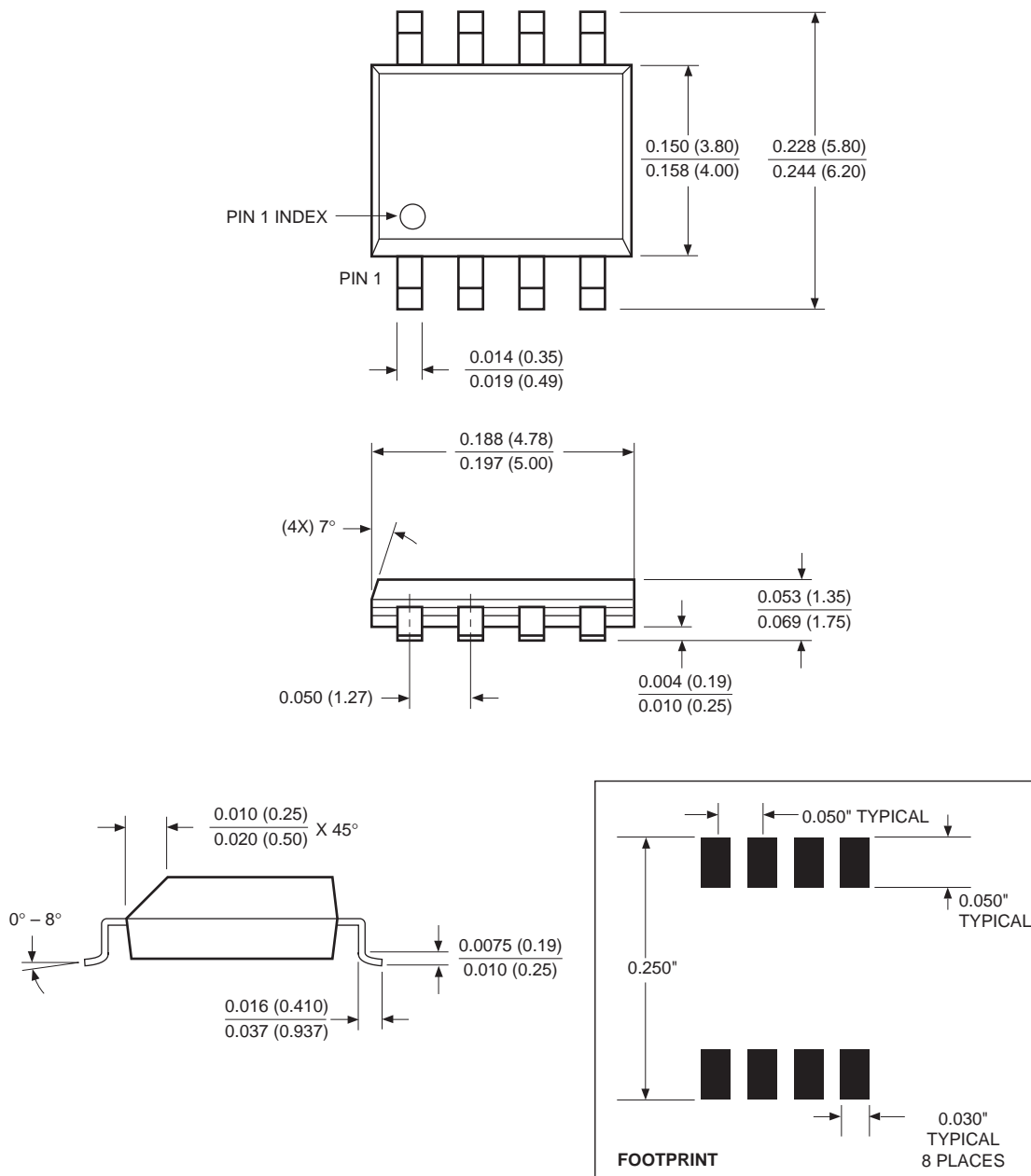
3926 FHD F01



# X24C44

## PACKAGING INFORMATION

### 8-LEAD PLASTIC SMALL OUTLINE GULL WING PACKAGE TYPE S



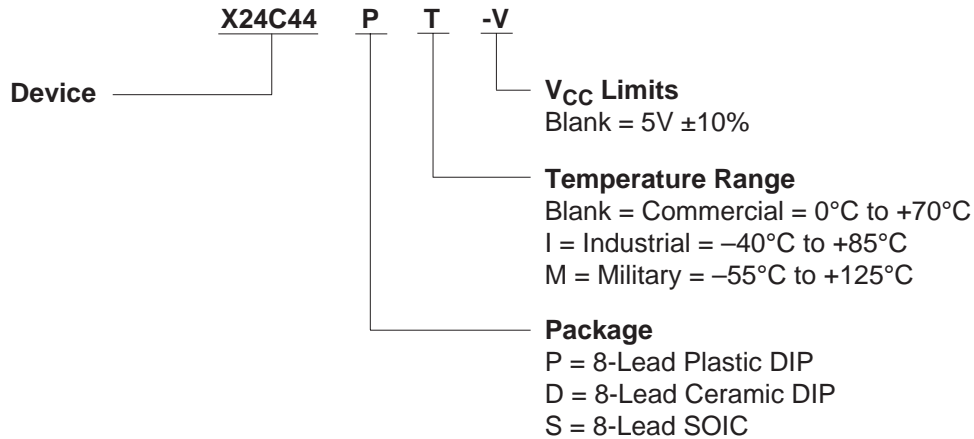
NOTE: ALL DIMENSIONS IN INCHES (IN PARENTHESES IN MILLIMETERS)

3926 FHD F22.1

# X24C44

---

## ORDERING INFORMATION



---

## LIMITED WARRANTY

Devices sold by Xicor, Inc. are covered by the warranty and patent indemnification provisions appearing in its Terms of Sale only. Xicor, Inc. makes no warranty, express, statutory, implied, or by description regarding the information set forth herein or regarding the freedom of the described devices from patent infringement. Xicor, Inc. makes no warranty of merchantability or fitness for any purpose. Xicor, Inc. reserves the right to discontinue production and change specifications and prices at any time and without notice.

Xicor, Inc. assumes no responsibility for the use of any circuitry other than circuitry embodied in a Xicor, Inc. product. No other circuits, patents, licenses are implied.

## US. PATENTS

Xicor products are covered by one or more of the following U.S. Patents: 4,263,664; 4,274,012; 4,300,212; 4,314,265; 4,326,134; 4,393,481; 4,404,475; 4,450,402; 4,486,769; 4,488,060; 4,520,461; 4,533,846; 4,599,706; 4,617,652; 4,668,932; 4,752,912; 4,829,482; 4,874,967; 4,883,976. Foreign patents and additional patents pending.

## LIFE RELATED POLICY

In situations where semiconductor component failure may endanger life, system designers using this product should design the system with appropriate error detection and correction, redundancy and back-up features to prevent such an occurrence.

Xicor's products are not authorized for use as critical components in life support devices or systems.

1. Life support devices or systems are devices or systems which, (a) are intended for surgical implant into the body, or (b) support or sustain life, and whose failure to perform, when properly used in accordance with instructions for use provided in the labeling, can be reasonably expected to result in a significant injury to the user.
2. A critical component is any component of a life support device or system whose failure to perform can be reasonably expected to cause the failure of the life support device or system, or to affect its safety or effectiveness.