

CoolMOS Power MOSFET in ISOPLUS247™ Package

IXKR 25N80C

V_{DSS}	I_{D25}	$R_{DS(on)}$
800 V	25 A	125 mΩ

N-Channel Enhancement Mode
Low $R_{DS(on)}$, High V_{DSS} MOSFET
Package with Electrically Isolated Base

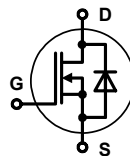

MOSFET

Symbol	Conditions	Maximum Ratings	
V_{DSS}	$T_{VJ} = 25^{\circ}\text{C}$ to 150°C	800	V
V_{GS}		± 20	V
I_{D25}	$T_C = 25^{\circ}\text{C}$	25	A
I_{D90}	$T_C = 90^{\circ}\text{C}$	18	A
dv/dt	$V_{DS} < V_{DSS}$; $I_F \leq 17\text{ A}$; $ di_F/dt \leq 100\text{ A}/\mu\text{s}$ $T_{VJ} = 150^{\circ}\text{C}$	6	V/ns
E_{AS}	$I_D = 4\text{ A}$; $L = 80\text{ mH}$; $T_C = 25^{\circ}\text{C}$	0.67	J
E_{AR}	$I_D = 17\text{ A}$; $L = 3.3\text{ }\mu\text{H}$; $T_C = 25^{\circ}\text{C}$	0.5	mJ

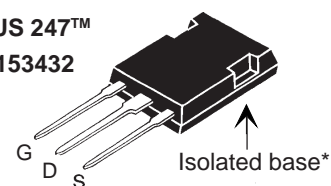
ISOPLUS 247™
E153432

G = Gate D = Drain S = Source
* Patent pending

Symbol	Conditions	Characteristic Values ($T_{VJ} = 25^{\circ}\text{C}$, unless otherwise specified)		
		min.	typ.	max.
$R_{DS(on)}$	$V_{GS} = 10\text{ V}$; $I_D = I_{D90}$		125	150 mΩ
$V_{GS(th)}$	$V_{DS} = 20\text{ V}$; $I_D = 2\text{ mA}$	2		4 V
I_{DSS}	$V_{DS} = V_{DSS}$; $V_{GS} = 0\text{ V}$; $T_{VJ} = 25^{\circ}\text{C}$ $T_{VJ} = 125^{\circ}\text{C}$		100	50 μA 50 μA
I_{GSS}	$V_{GS} = \pm 20\text{ V}$; $V_{DS} = 0\text{ V}$			200 nA
Q_g Q_{gs} Q_{gd}	} $V_{GS} = 10\text{ V}$; $V_{DS} = 640\text{ V}$; $I_D = 34\text{ A}$		166	nC
			18	nC
			84	nC
$t_{d(on)}$ t_r $t_{d(off)}$ t_f	} $V_{GS} = 10\text{ V}$; $V_{DS} = 640\text{ V}$; $I_D = 34\text{ A}$; $R_G = 2.2\text{ }\Omega$		25	ns
			15	ns
			72	ns
			6	ns
V_F	(reverse conduction) $I_F = 12.5\text{ A}$; $V_{GS} = 0\text{ V}$	1	1.3	V
R_{thJC}				0.5 K/W

Features

- ISOPLUS247 package with DCB Base
 - Electrical isolation towards the heatsink
 - Low coupling capacitance to the heatsink for reduced EMI
 - High power dissipation
 - High temperature cycling capability of chip on DCB
 - JEDEC TO247AD compatible
 - Easy clip assembly
- fast CoolMOS power MOSFET - 3rd generation
 - High blocking capability
 - Low on resistance
 - Avalanche rated for unclamped inductive switching (UIS)
 - Low thermal resistance due to reduced chip thickness
- Enhanced total power density

Applications

- Switched mode power supplies (SMPS)
- Uninterruptible power supplies (UPS)
- Power factor correction (PFC)
- Welding
- Inductive heating

*CoolMOS is a trademark of Infineon Technologies AG.

Component

Symbol	Conditions	Maximum Ratings	
V_{ISOL}	$I_{ISOL} \leq 1 \text{ mA}; 50/60 \text{ Hz}$	2500	V~
T_{VJ}		-40...+150	°C
T_{stg}		-40...+125	°C
T_L	1.6 mm from case for 10 s	300	°C
F_C	mounting force with clip	20 ... 120	N

Symbol	Conditions	Characteristic Values		
		min.	typ.	max.
C_p	coupling capacity between shorted pins and mounting tab in athe case		30	pF
R_{thCH}	with heatsink compound		0.25	K/W
Weight			6	g

ISOPLUS 247 OUTLINE

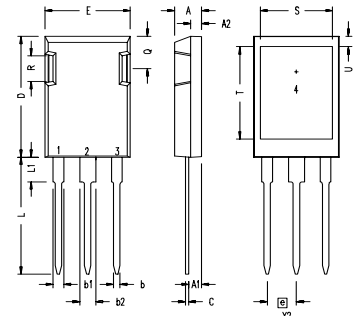

1 Gate, 2 Drain (Collector)
3 Source (Emitter)
4 no connection

Dim.	Millimeter		Inches	
	Min.	Max.	Min.	Max.
A	4.83	5.21	.190	.205
A ₁	2.29	2.54	.090	.100
A ₂	1.91	2.16	.075	.085
b	1.14	1.40	.045	.055
b ₁	1.91	2.13	.075	.084
b ₂	2.92	3.12	.115	.123
C	0.61	0.80	.024	.031
D	20.80	21.34	.819	.840
E	15.75	16.13	.620	.635
e	5.45 BSC		.215 BSC	
L	19.81	20.32	.780	.800
L1	3.81	4.32	.150	.170
Q	5.59	6.20	.220	.244
R	4.32	4.83	.170	.190