

Dialight



SafeSite® LED Signaling for Hazardous Locations

www.dialight.com

Dialight



SafeSite® L-864 Red LED Medium Intensity Beacon

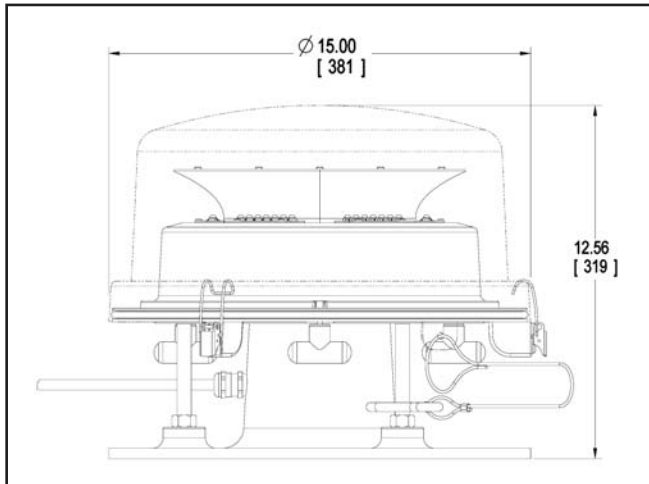

Dimensions in Inches [mm]

Certifications & Ratings:

- ▷ Class I, Div 2, Groups A, B, C, D hazardous environments T5 rated
- ▷ ATEX certified, equipment group II (surface industries), category 3 (Zone 2), T4 rated
- ▷ FAA AC No. 150/5345-43F
- ▷ Compliant to: ICAO (Annex 14 - Fourth Edition, July 2004), DGAC Mexico
- ▷ Canadian Aviation Regulation CAR 621.9 (Transport Canada)
- ▷ IP66 / NEMA 4X rated
- ▷ ETL Listed in compliance with UL1598 and UL844 for use in Class I, Div 2 hazardous locations

Features & Benefits:

- ▷ Uses 90% less energy than an incandescent
- ▷ Resistant to shock and vibration
- ▷ Lasts years longer than an incandescent
- ▷ Flash or steady burn
- ▷ 5 year warranty

Order Codes:

Class 1, Div 2 Beacon	
D164-B13-001	Class I, Div 2 120/230 VAC Beacon
ATEX Beacon	
D264-D13-001	ATEX 120/230 VAC Beacon

Application:

Dialight's L864 LED Based Class I, Division 2 certified medium intensity red beacon was designed to easily interface into existing systems or to be provided as a red lighting fixture for new installations. The beacon is used to mark any obstacle that may provide hazards to aircraft navigation. Versions of this fixture are available in 120VAC or 230VAC.

Mechanical Information:

Container Dimensions: 24" X 24" X 24"
610mm x 610mm x 610mm

Container Weight: 32lbs (12.70 kg)

Mounting:

Electrical specifications:

Current (Amps): 0.4 / 0.2

Power Consumption (nom): 48 W

Operating Temp: -40°F to +133°F (-40°C to +55°C)

Power Factor: > 0.9

Material:

Housing: Cast aluminum

Lens: Polycarbonate

Accessories (Hardware): Stainless steel

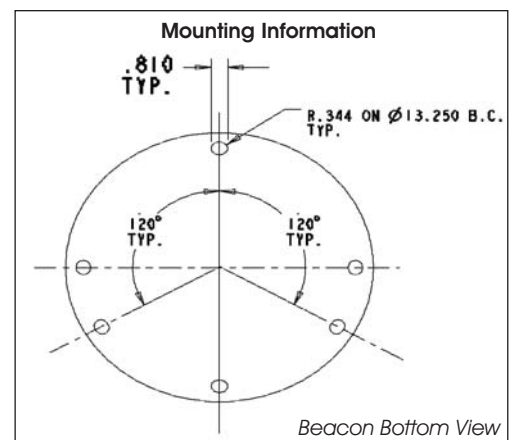



Application:

LED Based L810 Red Obstruction light certified to meet both the rigorous FAA requirements for red LED obstruction lights and Class I, Division 2 for hazardous area lighting locations. It is available in 120VAC or 230VAC versions and can be ordered as single or dual units.

SafeSite® L-810 Red LED Obstruction Lights

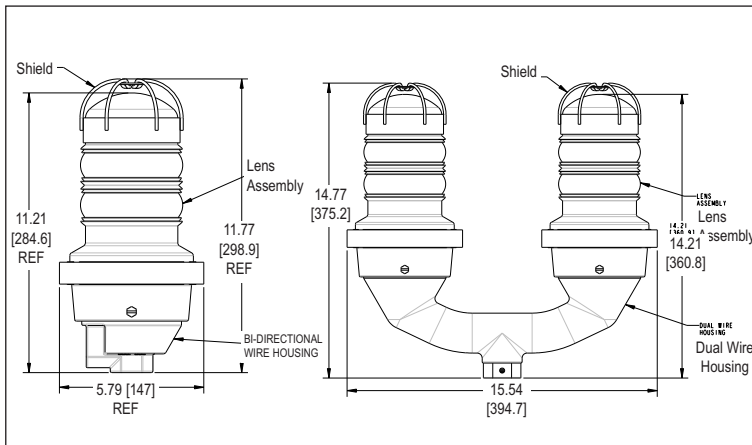

Dimensions in Inches [mm]

Certifications & Ratings:

- ▷ Class I, Div 2, Groups A, B, C, D hazardous environments T4 rated
- ▷ ATEX certified, equipment group II (surface industries), category 3 (Zone 2), T4 rated
- ▷ FAA AC No. 150/5345-43F
- ▷ Compliant to: ICAO (Annex 14 - Fourth Edition, July 2004), DGAC Mexico
- ▷ Canadian Aviation Regulation CAR 621.9(Transport Canada)
- ▷ ETL Listed in compliance with UL1598 and UL844 for use in Class I, Div 2 hazardous locations
- ▷ IP65 / IP66 / NEMA 4X rated

Features & Benefits:

- ▷ Uses 90% less energy than an incandescent
- ▷ Weather/corrosion resistant lamp assembly and housing
- ▷ Resistant to shock and vibration
- ▷ Available as a single or dual unit
- ▷ Unique optically designed lens to enhance LED operation and provide 360° visibility
- ▷ Flash or steady burn
- ▷ Will withstand wind in excess of 150 mph (240 kph), salt fog
- ▷ 5 year warranty

Order Codes:

Class 1, Div 2 Units		ATEX Units	
860-2R01-001	Class I, Div 2 120 VAC, Single Unit	860-9R01-001	ATEX 120 VAC, Single Unit
860-2R02-001	Class I, Div 2 230 VAC, Single Unit	860-9R02-001	ATEX 230 VAC, Single Unit
860-2R01-002	Class I, Div 2 120 VAC, Dual Unit	860-9R01-002	ATEX 120 VAC, Dual Unit
860-2R02-002	Class I, Div 2 230 VAC, Dual Unit	860-9R02-002	ATEX 230 VAC, Dual Unit

Mechanical Information:

Single Units:

- Container Dimensions:** 16" X 9" X 8"
406mm x 229mm x 203mm
- Container Weight:** 7.14 lbs (3.24 kg)
- Mounting:** Threaded 1" NPT and 3/4" NPT bottom hub for mounting

Dual Units:

- Container Dimensions:** 22" X 17" X 9"
559mm x 432mm x 229mm
- Container Weight:** 16.06 lbs (7.28 kg)
- Mounting:** Threaded 1" NPT and 3/4" NPT bottom hub for mounting

Electrical specifications: (Per Light):

- Volt Amps:** 44 VA (120 VAC Units)
67 VA (230 VAC Units)
- Input Power:** 14.5 W (120 VAC Units)
16.0 W (230 VAC Units)
- Operating Temp:** -67°F to +131°F (-55°C to +55°C)

Material:

- Housing:** Cast aluminum
- Lens:** Glass
- Accessories (Hardware):** Stainless steel

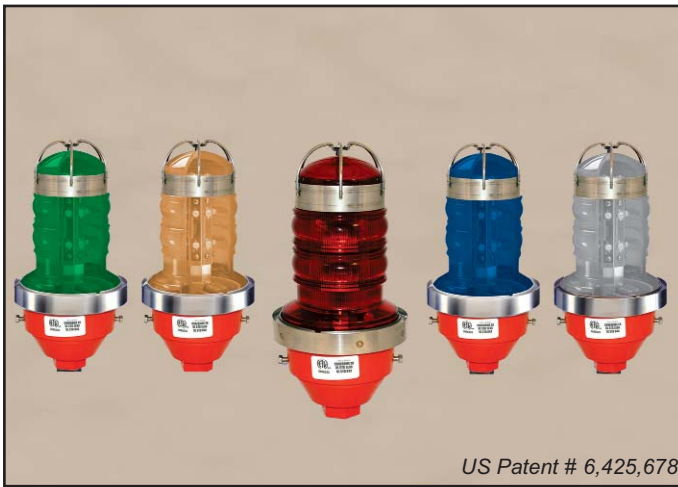

SafeSite® 860 Series LED Steady Burn Visual Signal Lights

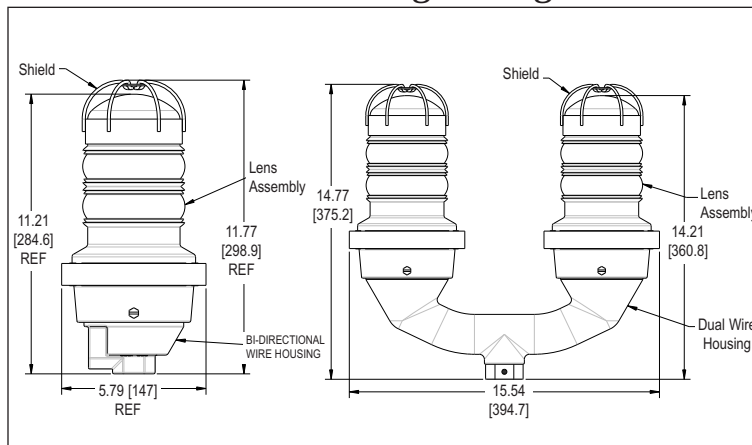

Dimensions in Inches [mm]

Certifications & Ratings:

- ▷ Class I, Div 2, Groups A, B, C, D hazardous environments T4 rated
- ▷ ATEX certified, equipment group II (surface industries), category 3 (Zone 2), T4 rated
- ▷ IP65 / IP66 / NEMA 4X rated
- ▷ ETL Listed in compliance with UL1598 and UL844 for use in Class I, Div 2 hazardous locations

Features & Benefits:

- ▷ Uses 90% less energy than an incandescent
- ▷ Weather/corrosion resistant lamp assembly and housing
- ▷ Resistant to shock and vibration
- ▷ Available as a single or dual unit
- ▷ Unique optically designed lens to enhance LED operation and provide 360° visibility
- ▷ 5 year warranty

Order Codes:

Class I, Div 2 - Single Units		Class I, Div 2 - Dual Units	
860-2R01-001	Class I, Div 2 Red 120 VAC	860-2R01-002	Class I, Div 2 Red 120 VAC
860-2W01-001	Class I, Div 2 White 120 VAC	860-2W01-002	Class I, Div 2 White 120 VAC
860-2G01-001	Class I, Div 2 Green 120 VAC	860-2G01-002	Class I, Div 2 Green 120 VAC
860-2Y01-001	Class I, Div 2 Yellow 120 VAC	860-2Y01-002	Class I, Div 2 Yellow 120 VAC
860-2B01-001	Class I, Div 2 Blue 120 VAC	860-2B01-002	Class I, Div 2 Blue 120 VAC
860-2R02-001	Class I, Div 2 Red 230 VAC	860-2R02-002	Class I, Div 2 Red 230 VAC
860-2W02-001	Class I, Div 2 White 230 VAC	860-2W02-002	Class I, Div 2 White 230 VAC
860-2G02-001	Class I, Div 2 Green 230 VAC	860-2G02-002	Class I, Div 2 Green 230 VAC
860-2Y02-001	Class I, Div 2 Yellow 230 VAC	860-2Y02-002	Class I, Div 2 Yellow 230 VAC
860-2B02-001	Class I, Div 2 Blue 230 VAC	860-2B02-002	Class I, Div 2 Blue 230 VAC

ATEX versions available - consult factory

Application:

Dialight's steady burn LED Based Class I, Division 2 Visual Signals are used in a wide range of industries for visual indication in hazardous environments. Versions of this fixture are available in 120VAC or 230VAC.

Mechanical Information:

Single Units:

Container Dimensions: 16" X 9" X 8"
406mm x 229mm x 203mm

Container Weight: 7.14 lbs (3.24 kg)

Mounting: Threaded 1" NPT and 3/4" NPT bottom hub for mounting

Dual Units:

Container Dimensions: 22" X 17" X 9"
559mm x 432mm x 229mm

Container Weight: 16.06 lbs (7.28 kg)

Mounting: Threaded 1" NPT and 3/4" NPT bottom hub for mounting

Electrical specifications: (Per Light):

Volt Amps: 44 VA (120 VAC Units)
67 VA (230 VAC Units)

Input Power: 14.5 W (120 VAC Units)
16.0 W (230 VAC Units)

Operating Temp: -67°F to +131°F (-55°C to +55°C)

Material:

Housing: Cast aluminum

Lens: Glass

Accessories (Hardware): Stainless steel



SafeSite® 860 Series LED Visual Signal Lights w/ Flat Base Junction Box

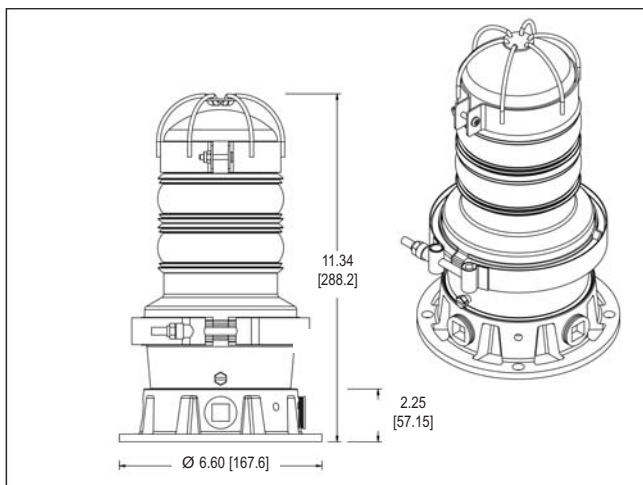

Dimensions in Inches [mm]

Certifications & Ratings:

- ▷ Class I, Div 2, Groups A, B, C, D hazardous environments (pending)
- ▷ IP65 / IP66 / NEMA 4X rated
- ▷ ETL Listed in compliance with UL1598 and UL844 for use in Class I, Div 2 hazardous locations

Features & Benefits:

- ▷ Uses 90% less energy than an incandescent
- ▷ Weather/corrosion resistant lamp assembly and housing
- ▷ Resistant to shock and vibration
- ▷ Unique optically designed lens to enhance LED operation and provide 360° visibility
- ▷ 5 year warranty

Order Codes:

Class I, Div 2 - Single Units	
860-2R01-005	Class I, Div 2 Red 120 VAC - Flat Base
860-2Y01-005	Class I, Div 2 Yellow 120 VAC - Flat Base
860-2B01-005	Class I, Div 2 Blue 120 VAC - Flat Base

Application:

Dialight's flat base junction box allows versatility of mounting and installation. It's flat bottom base design creates the ability to mount the visual signal against level surfaces such as walls, ceilings and platforms.

Mechanical Information:

Container Dimensions: 16" X 9" X 8"
406mm x 229mm x 203mm

Container Weight: 7.14 lbs (3.24 kg)

Mounting: Threaded 1" NPT on 4 sides and 1 on bottom

Electrical specifications:

Volt Amps: 44 VA (120 VAC Units)

Input Power: 14.5 W (120 VAC Units)

Operating Temp: -67°F to +131°F (-55°C to +55°C)

Material:

Housing: Cast aluminum

Lens: Glass

Accessories (Hardware): Stainless steel



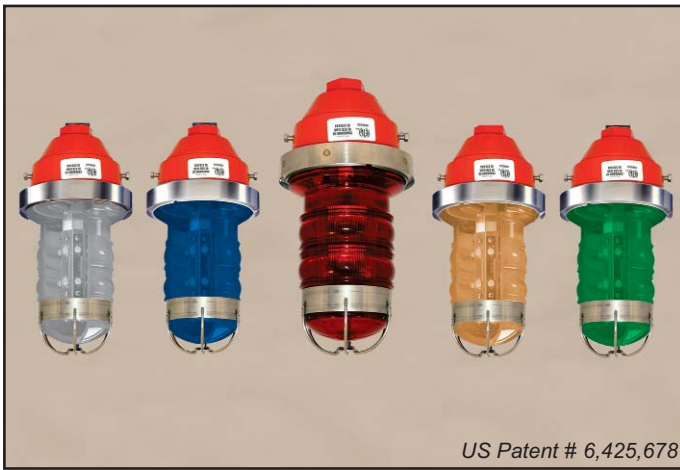

US Patent # 6,425,678

SafeSite® FLS Series LED Flashing Visual Signal Lights

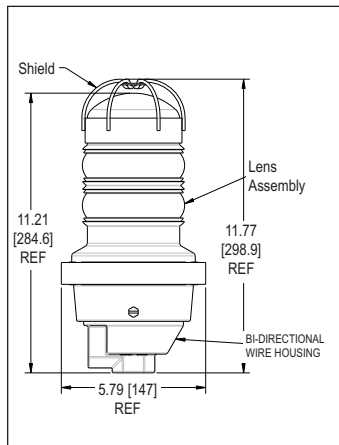

Dimensions in Inches [mm]

Certifications & Ratings:

- ▷ Class I, Div 2, Groups A, B, C, D hazardous environments T4 rated
- ▷ IP66 / NEMA 4X rated
- ▷ ETL Listed in compliance with UL1598 and UL844 for use in Class I, Div 2 hazardous locations

Features & Benefits:

- ▷ Uses 90% less energy than an incandescent
- ▷ Weather/corrosion resistant lamp assembly and housing
- ▷ Resistant to shock and vibration
- ▷ Available as a single unit
- ▷ Unique optically designed lens to enhance LED operation and provide 360° visibility
- ▷ 5 year warranty

Order Codes:

Class I, Div 2 - Single Units	
FLS-2R01-001	Class I, Div 2 Red 120 VAC
FLS-2W01-001	Class I, Div 2 White 120 VAC
FLS-2G01-001	Class I, Div 2 Green 120 VAC
FLS-2Y01-001	Class I, Div 2 Yellow 120 VAC
FLS-2B01-001	Class I, Div 2 Blue 120 VAC
FLS-2R02-001	Class I, Div 2 Red 230 VAC
FLS-2W02-001	Class I, Div 2 White 230 VAC
FLS-2G02-001	Class I, Div 2 Green 230 VAC
FLS-2Y02-001	Class I, Div 2 Yellow 230 VAC
FLS-2B02-001	Class I, Div 2 Blue 230 VAC

ATEX versions available - consult factory

Application:

Dialight's newest addition to their line of Class I, Division 2 Visual Signal Lights, the FLS Series Flashing Signals are used in a wide range of industries for visual indication in hazardous environments. Versions of this fixture are available in 120VAC or 230VAC.

Mechanical Information:

Container Dimensions: 16" X 9" X 8"
406mm x 229mm x 203mm

Container Weight: 7.14 lbs (3.24 kg)

Mounting: Threaded 1" NPT and 3/4" NPT bottom hub for mounting

Electrical specifications:

Volt Amps: 44 VA (120 VAC Units)
67 VA (230 VAC Units)

Input Power: 14.5 W (120 VAC Units)
16.0 W (230 VAC Units)

Operating Temp: -67°F to +131°F (-55°C to +55°C)

Material:

Housing: Cast aluminum

Lens: Glass

Accessories (Hardware): Stainless steel



SafeSite® FLS Series LED Flashing Signal Lights w/ Flat Base Junction Box

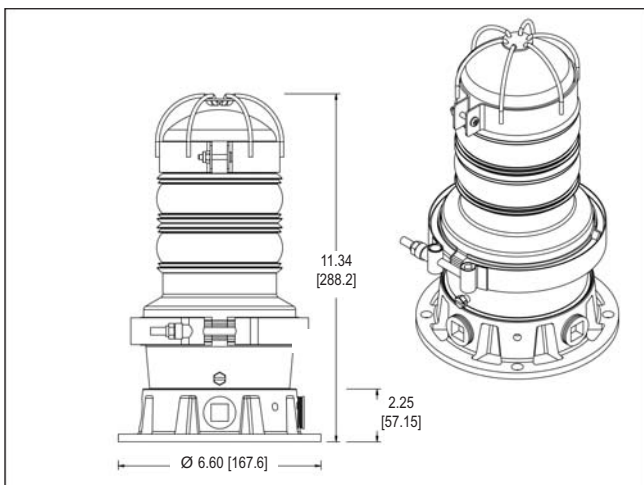

Dimensions in Inches [mm]

Application:

Dialight's flat base junction box allows versatility of mounting and installation. It's flat bottom base design creates the ability to mount the flashing signal against level surfaces such as walls, ceilings and platforms.

Mechanical Information:

Container Dimensions: 16" X 9" X 8"
406mm x 229mm x 203mm

Container Weight: 7.14 lbs (3.24 kg)

Mounting: Threaded 1" NPT on 4 sides and 1 on bottom

Electrical specifications:

Volt Amps: 44 VA (120 VAC Units)

Input Power: 14.5 W (120 VAC Units)

Operating Temp: -67°F to +131°F (-55°C to +55°C)

Material:

Housing: Cast aluminum

Lens: Glass

Accessories (Hardware): Stainless steel

Certifications & Ratings:

- ▷ Class I, Div 2, Groups A, B, C, D hazardous environments (pending)
- ▷ IP65 / IP66 / NEMA 4X rated

Features & Benefits:

- ▷ ETL Listed in compliance with UL1598 and UL844 for use in Class I, Div 2 hazardous locations
- ▷ Uses 90% less energy than an incandescent
- ▷ Weather/corrosion resistant lamp assembly and housing
- ▷ Resistant to shock and vibration
- ▷ Unique optically designed lens to enhance LED operation and provide 360° visibility
- ▷ 5 year warranty

Order Codes:

Class I, Div 2 - Single Units	
FLS-2R01-005	Class I, Div 2 Red 120 VAC - Flat Base
FLS-2Y01-005	Class I, Div 2 Yellow 120 VAC - Flat Base
FLS-2B01-005	Class I, Div 2 Blue 120 VAC - Flat Base



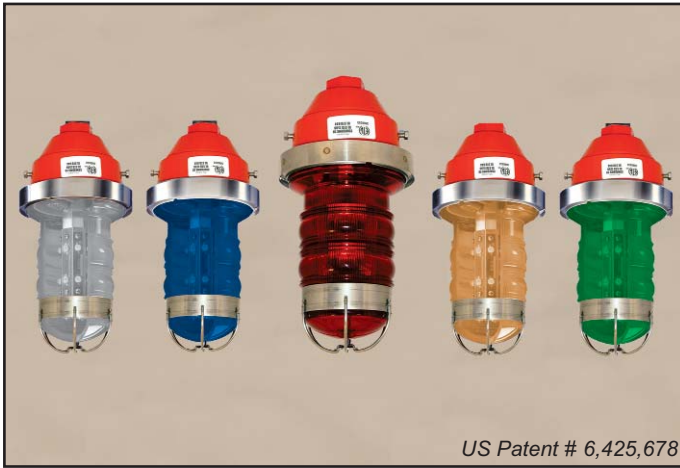

SafeSite® FLS Series LED Flashing Visual Signal Lights for Supervised Alarm Systems

Certifications & Ratings:

- ▷ Class I, Div 2, Groups A, B, C, D hazardous environments T4 rated
- ▷ Certified to UL844 / UL1598A / DL1598
- ▷ IP66 / NEMA 4X rated

Features & Benefits:

- ▷ Uses 90% less energy than an incandescent
- ▷ Weather/corrosion resistant lamp assembly and housing
- ▷ Resistant to shock and vibration
- ▷ Unique optically designed lens to enhance LED operation and provide 360° visibility
- ▷ 5 year warranty

Order Codes:

Class I, Div 2 - Single Units	
FLS-2R09-001	Red
FLS-2W09-001	White
FLS-2G09-001	Green
FLS-2Y09-001	Yellow
FLS-2B09-001	Blue

Application:

Dialight's newest addition to their line of Class I, Division 2 Visual Signal Lights, the FLS Series Flashing Signals are used in a wide range of industries for visual indication in hazardous environments. The FLS series incorporates a 4 wire connection for incorporation into a DC supervised alarm systems.

Mechanical Information:

Container Dimensions: 16" X 9" X 8"
406mm x 229mm x 203mm

Container Weight: 7.14 lbs (3.24 kg)

Mounting: Threaded 1" NPT

Electrical specifications:

Operating Voltage: 12-48 VDC (nom)

Input Power: 1.5 W

Operating Temp: -40°C to +65°C

On:Off Time: 100:900ms

Material:

Housing: Powder coated cast aluminum

Lens: Glass

Hardware: Stainless steel

Included Accessories: Threaded 3/4" NPT reducer
Threaded 1" NPT plug
Stainless steel cage

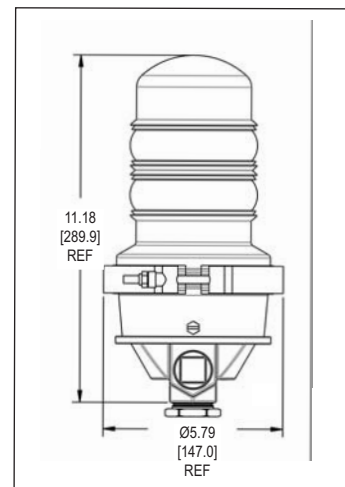

Dimensions in Inches [mm]

Dialight reserves the right to make changes at any time in order to supply the best product possible.

The most current version of this document will always be available at:

http://www.dialight.com/Assets/Brochures_And_Catalogs/Illumination/MDTFSFSTBROCHURE.pdf

MDTFSFSTBROCHURE_D