

POSITRONIC INDUSTRIES BELIEVES THE DATA ON THIS DRAWING TO BE RELIABLE. SINCE THE TECHNICAL INFORMATION IS GIVEN FREE OF CHARGE, THE USER EMPLOYS SUCH INFORMATION AT HIS OWN DISCRETION AND RISK. POSITRONIC INDUSTRIES ASSUMES NO RESPONSIBILITY FOR RESULTS OBTAINED OR DAMAGES INCURRED FROM USE OF SUCH INFORMATION IN WHOLE OR IN PART.

DATE	REV	REVISION RECORD	APP	DR	CK
3-19-04	NC	ECO 22183	RCW	YK	COLE
7-27-05	A	ECO 24419	RCW	LO	TK
2-23-06	B	ECO 25553		ME	

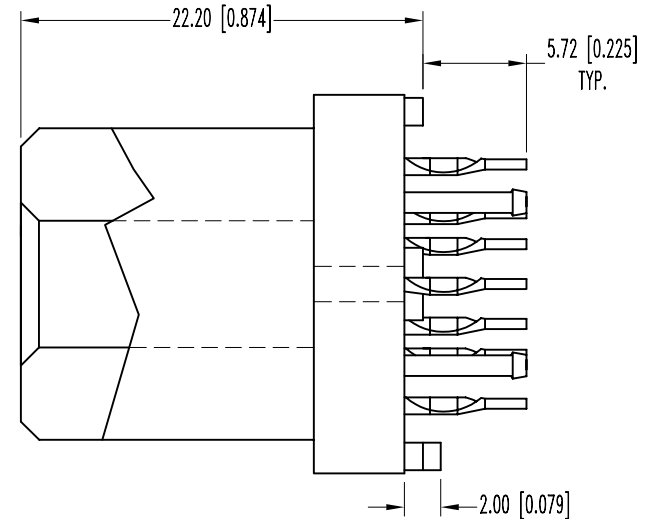
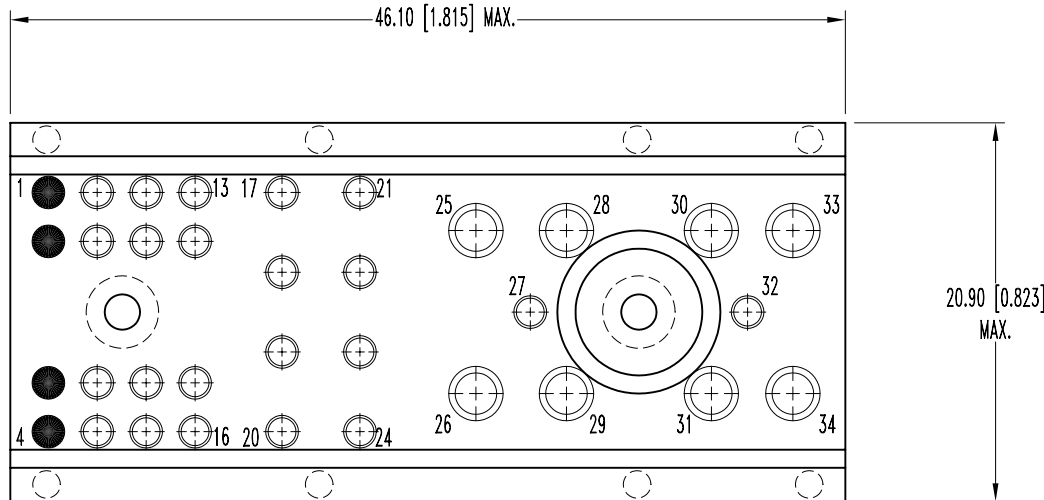

NOTES:

1. MATERIALS AND FINISHES:

- INSULATOR: GLASS FILLED POLYESTER, UL 94V-0. COLOR: BLUE.
- SIZE 16 CONTACTS: PRECISION MACHINED COPPER ALLOY WITH 0.80µ [0.00030] GOLD OVER NICKEL.
- SIZE 22 CONTACTS: PRECISION MACHINED COPPER ALLOY WITH 0.80µ [0.00030] GOLD OVER NICKEL.

2. ELECTRICAL CHARACTERISTICS:

- CONTACT CURRENT RATING, PER UL 1977. SEE TEMPERATURE RISE CURVE FOR DETAILS.
- SIZE 16 POWER CONTACTS: 30 AMPERES CONTINUOUS, ALL CONTACTS UNDER LOAD.
- SIZE 22 SIGNAL CONTACTS: 2 AMPERES NOMINAL RATING.
- INITIAL CONTACT RESISTANCE: TERMINATION TO TERMINATION
- SIZE 16 CONTACTS: 0.0022 ohms MAXIMUM.
- SIZE 22 CONTACTS: 0.0085 ohms MAXIMUM, PER IEC 512-2 Test 2b.
- INSULATOR RESISTANCE: 5 G ohms PER IEC 512-2 TEST 3a.
- PROOF VOLTAGE:
 - CONTACTS 5-16: 1,000 V r.m.s.
 - CONTACTS 17-34: 2,000 V r.m.s.
- CREEPAGE AND CLEARANCE DISTANCE; MINIMUM:
 - CONTACTS POSITIONS 5-16 TO ANY OTHER CONTACT WITHIN THIS GROUP: 0.7mm [0.028 inch]
 - CONTACTS POSITIONS 17-24 TO ANY OTHER CONTACT WITHIN THIS GROUP: 2.5mm [0.098 inch]
 - CONTACTS POSITIONS 25-34 TO ANY OTHER CONTACT WITHIN THIS GROUP: 1.4mm [0.055 inch]
 - CONTACTS POSITIONS 13-16 TO 17-20: 3.0 mm [0.055 inch].
 - CONTACTS POSITIONS 21-24 TO 25,26: 4.0 mm [0.157 inch].
 - CONTACTS POSITIONS 25, 26 TO 27-29: 2.0mm [0.079 inch].

- 3. USES 2X PHILLIPS PAN HEAD SELF TAPPING SCREW, 2-28 TRIPLASK II TRILOBULAR THREADS OR EQUIVALENT. INSTALL SCREW TO A DEPTH OF 3 mm MINIMUM, 5mm MAXIMUM.
- 4. WORKING TEMPERATURE: -55°C TO 125°C.
- 5. DIMENSIONS ARE IN MILLIMETERS [INCHES].

CONTACT NUMBER	CIRCUIT	SEQUENTIAL MATING
5-16	HARDWARE MANAGEMENT	BEFORE ENABLE
17-24	ANALOG TEST	BEFORE ENABLE
26	LOGIC GROUND	FIRST
25	EMI CHASSIS GROUND	FIRST
29	VRTN_B	FIRST
28	VRTN_A	FIRST
27	ENABLE B	LAST
32	ENABLE A	LAST
31	-48V_EARLY_B	FIRST
30	-48V_EARLY_A	FIRST
34	-48V_B	THIRD (2.5mm MINIMUM TO ENABLE)
33	-48V_A	SECOND

ALL FIRST MATE CONTACTS ENGAGE PRIOR TO SHIELDS OF ZD CONNECTOR



POSITRONIC INDUSTRIES INC.
www.connectpositronic.com

DECIMAL TOL. ± 0.38 [0.015]	VP SERIES	SCALE N.T.S.	DRAWN BY YK
	TITLE VPB30W8F9300C1	APPROVED BY R. WILLIAMS	
ANGULAR TOL. ± 5°	DATE 3-19-04	DRAWING NUMBER SK5365	REV. B

POSTORIC INDUSTRIES BELIEVES THE DATA ON THIS DRAWING TO BE RELIABLE SINCE THE TECHNICAL INFORMATION IS GIVEN FREE OF CHARGE. THE USER EMPLOYS SUCH INFORMATION AT HIS OWN DISCRETION AND POSTORIC INDUSTRIES ASSUMES NO LIABILITY OR RESPONSIBILITY FOR RESULTS OBTAINED OR DAMAGES INCURRED FROM USE OF SUCH INFORMATION IN WHOLE OR IN PART.

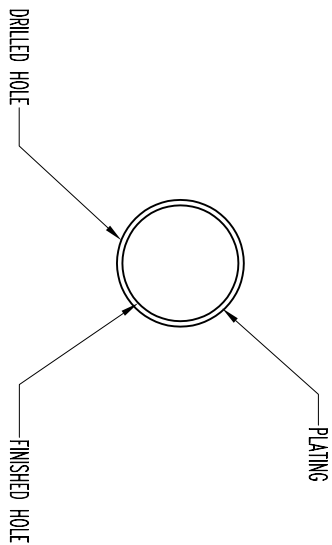

DRILLED HOLE
FINISHED HOLE
PLATING

DETAIL A

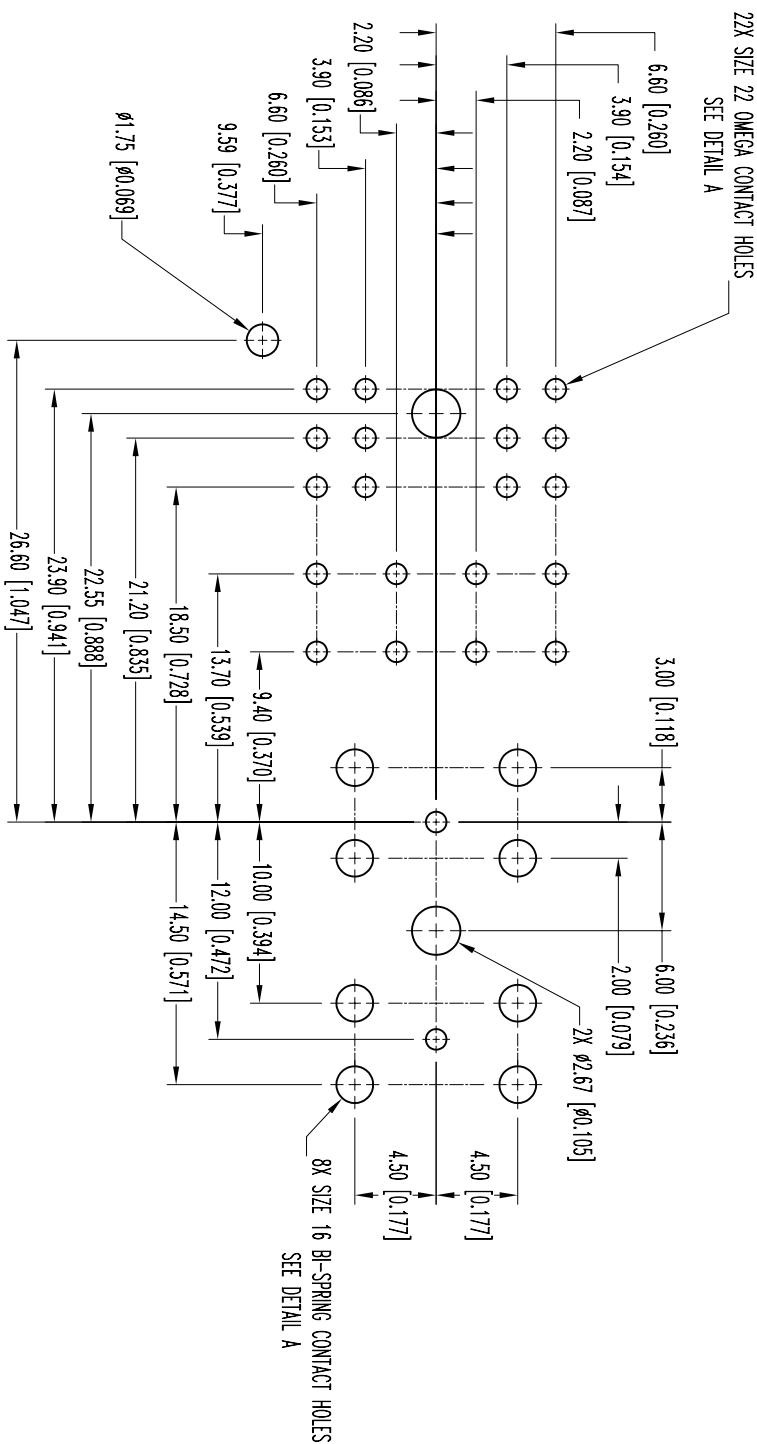

CONTACT HOLE PATTERN

DRAWING NUMBER	SK6365
SHEET	2 OF 2
REV.	B



Positronic Industries
white
paper

Positronic's Blue Connectors are Green



POSITRONIC INDUSTRIES, INC.

423 N Campbell Avenue
PO Box 8247
Springfield, MO 65801
Toll Free (800) 641-4054
Tel (417) 866-2322
Fax (417) 866-4115
info@connectpositronic.com



POSITRONIC INDUSTRIES, S.A.S.

Zone Industrielle d'Engachies
46 Route d'Engachies
France 32020 Auch Cedex
Telephone 33 5 62 63 44 91
Fax 33 5 62 63 51 17
contact@connectpositronic.com



POSITRONIC ASIA PTE LTD.

3014A Ubi Road 1 #07-01
Singapore 408703
Telephone (65) 6842 1419
Fax (65) 6842 1421
singapore@connectpositronic.com

Energy is essential to everyone. Often we do not give thought to where energy comes from or how much we consume until energy is not readily available.

Energy has become an area of focus for governments, private industry, and citizens. Enhanced methods of producing energy from traditional sources, development of new energy sources and conservation of energy from all sources have become more crucial than ever before.

Across the world, a vast amount of energy is consumed by the electronic equipment which we all rely upon in our daily lives. An unavoidable waste of energy occurs when power is distributed throughout electronic equipment. As electrical current flows through conductors and connectors, unwanted heat is generated in proportion to the amount of electrical resistance encountered.

Lowering resistance in connector contacts and conductors will reduce the amount of heat generated, and result in less lost or wasted energy. Additional energy will be saved as cooling systems will have less heat to draw out of the equipment.

In the past, the primary metric for power connectors has been contact current ratings. In the future, contact resistance may become equally important. While it is true that contact resistance and contact current ratings are closely associated, contact current ratings cannot be used to quantify the energy consumed by contacts.

Current ratings are based on the temperature rise of a connector or contact at a specific current level. A connector design or test method allowing relatively rapid heat dissipation may yield a reasonable temperature rise, while a relatively high amount of energy is still being wasted.

Within the connector industry, there are a variety of test methods used to quantify a particular performance metric. Different test methods can yield different values for the same metric. This lack of uniformity can be confusing to connector users who are trying to compare connectors offered by various manufacturers. Third party assessment can give connector users a common point of reference when making connector choices.

Contact resistance is used by **UL Environment** as the metric to determine the relative efficiency of connector contacts. **UL Environment** offers independent third party assessment and verification of claims made by manufacturers.

continued on next page

Once assessments are made, **UL Environment** issues an Environmental Claims Validated (ECV) Mark, in this case contact resistance. The ECV will aid power connector users in evaluating contact efficiency as it relates to energy consumption. Visit www.ulenvironment.com for more information.

As an example, recently an ECV was presented to **Positronic** by **UL Environment**. The ECV lists the average contact resistance for **Positronic's** VPB series size 16 power contacts at less than one milliohm each. This low contact resistance is achieved by use of high conductivity contact materials. In addition, **Positronic's** Large Surface Area (LSA) contact system is utilized as the interface between male and female power contacts in VPB series connectors.

The VPB series was designed for use as the Zone 1 power connector in AdvancedTCA (ATCA) telecommunication computing systems. Zone 1 connectors provide power from backplanes to front boards in ATCA chassis. The low contact resistance of **Positronic's** VPB series provides energy savings opportunities in any application using this connector.

The following formula verifies the energy savings of a lower resistance contact at a given current: **Power Consumption (Watts) = Current Flow² (Amperes²) X Contact Resistance (Ohms)** Contact resistance has a one-to-one effect on power consumption. If, the contact resistance is reduced by half, the power consumption is reduced by half.

Low resistance power contacts also provide benefits in systems sensitive to voltage drop. This is demonstrated in the following formula: **Voltage drop across contact pairs = Current Flow (Amperes) X Contact Resistance (Ohms)**. Once again, contact resistance has a one-to-one effect. Reducing the contact resistance by half reduces voltage drop by half.

Higher energy costs and government legislation will cause energy conservation efforts to continue to intensify. If we consider the vast numbers of power contacts in electronic equipment around the world, it is clear how lower contact resistance can play a role in meeting

energy conservation goals. **Positronic** utilizes high conductivity contact materials and unique contact interfaces to provide low contact resistance in our power connector products. To learn more about these products, visit connectpositronic.com.



Positronic Industries white paper



POSITRONIC INDUSTRIES, INC.

423 N Campbell Avenue
 PO Box 8247
 Springfield, MO 65801
 Toll Free (800) 641-4054
 Tel (417) 866-2322
 Fax (417) 866-4115
info@connectpositronic.com



POSITRONIC INDUSTRIES, S.A.S.

Zone Industrielle d'Engachies
 46 Route d'Engachies
 France 32020 Auch Cedex
 Telephone 33 5 62 63 44 91
 Fax 33 5 62 63 51 17
contact@connectpositronic.com



POSITRONIC ASIA PTE LTD.

3014A Ubi Road 1 #07-01
 Singapore 408703
 Telephone (65) 6842 1419
 Fax (65) 6842 1421
singapore@connectpositronic.com