

High-accuracy EPROM Programmable Single-PLL Clock Generator

Features

- High-accuracy PLL with 12-bit multiplier and 10-bit divider
- EPROM programmability
- 3.3V or 5V operation
- Operating frequency
 - 390 kHz–133 MHz at 5V
 - 390 kHz–100 MHz at 3.3V
- Reference input from either a 10–30 MHz fundamental toned crystal or a 1–75 MHz external clock
- EPROM selectable TTL or CMOS duty cycle levels
- Sixteen selectable post-divide options, using either PLL or reference oscillator/external clock
- Programmable PWR_DWN or OE pin, with asynchronous or synchronous modes
- Low jitter outputs typically
 - 80 ps at 3.3V/5V
- Controlled rise and fall times and output slew rate
- Available in both commercial and industrial temperature ranges
- Factory programmable device options

Benefits

- Enables synthesis of highly accurate and stable output clock frequencies with zero PPM
- Enables quick turnaround of custom frequencies
- Supports industry standard design platforms
- Services most PC, networking, and consumer applications
- Lowers cost of oscillator as PLL can be programmed to a high frequency using either a low-frequency, low-cost crystal, or an existing system clock
- Duty cycle centered at 1.5V or $V_{DD}/2$
- Provides flexibility to service most TTL or CMOS applications
- Provides flexibility in output configurations and testing
- Enables low-power operation or output enable function and flexibility for system applications, through selectable instantaneous or synchronous change in outputs
- Suitable for most PC, consumer, and networking applications
- Has lower EMI than oscillators
- Suitable to fit most applications
- Easy customization and fast turnaround

Logic Block Diagram

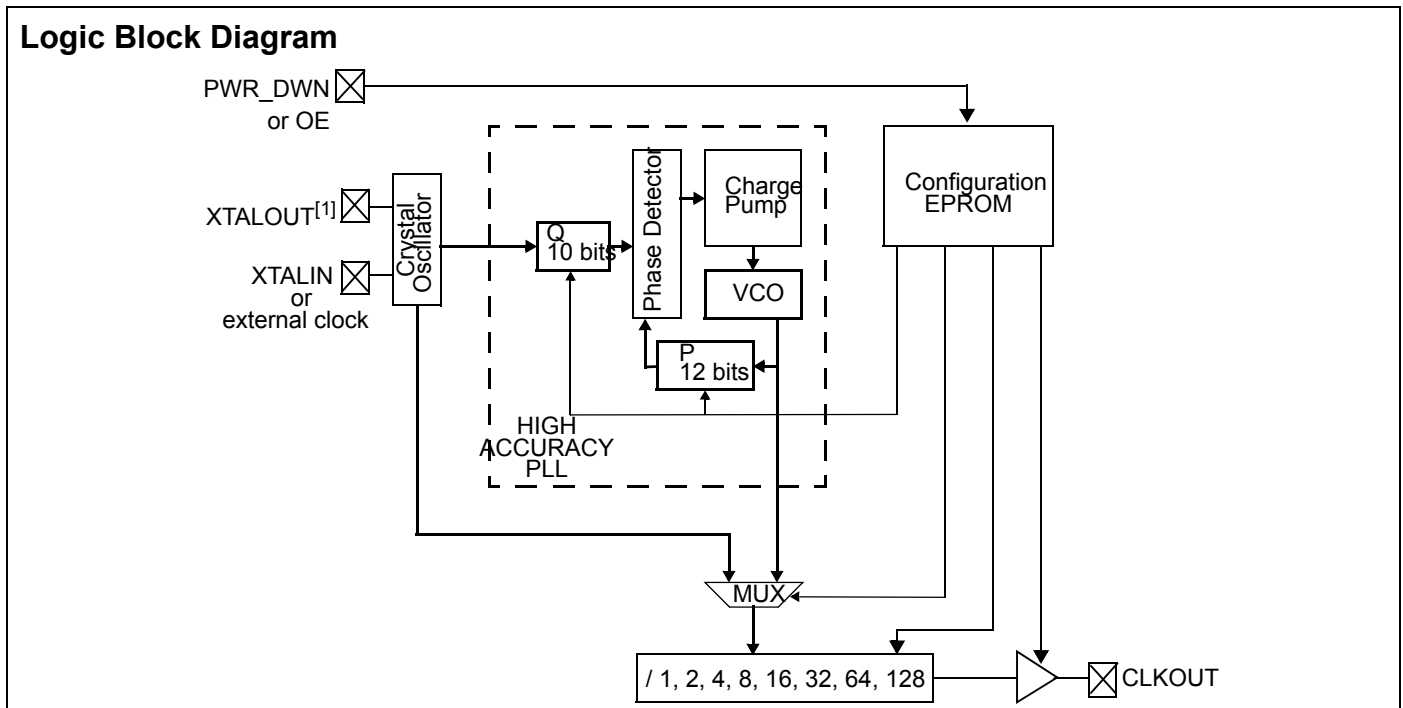

Note

1. When using an external clock source, leave XTALOUT floating.

Pinouts

Figure 1. Pin Diagram - 8 Pin Top View

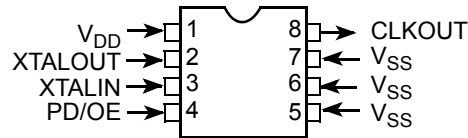

Table 1. Pin Definition - 8 Pin

Pin Name	Pin #	Pin Description
V _{DD}	1	Voltage supply
V _{SS}	5,6,7	Ground (all the pins must be grounded)
X _D	2	Crystal output (leave this pin floating when external reference is used)
X _G	3	Crystal input or external input reference
PWR_DWN / OE	4	EPROM programmable power down or output enable pin. PWR_DWN is active low. OE is active high. Weak pull up.
CLKOUT	8	Clock output. Weak pull down

Functional Description

CY2077 is an EPROM-programmable, high-accuracy, general-purpose, PLL-based design for use in applications such as modems, disk drives, CD-ROM drives, video CD players, DVD players, games, set-top boxes, and data/telecommunications.

CY2077 can generate a clock output up to 133 MHz at 5V or 100 MHz at 3.3V. It has been designed to give the customer a very accurate and stable clock frequency with little to zero PPM error. CY2077 contains a 12-bit feedback counter divider and 10-bit reference counter divider to obtain a very high resolution to meet the needs of stringent design specifications. Furthermore, there are eight output divide options of /1, /2, /4, /8, /16, /32, /64, and /128. The output divider can select between the PLL and crystal oscillator output/external clock, providing a total of 16 different options to add more flexibility in designs. TTL or CMOS duty cycles can be selected.

Power management with the CY2077 is also very flexible. The user can choose either a PWR_DWN, or an OE feature with which both have integrated pull up resistors. PWR_DWN and OE signals can be programmed to have asynchronous and synchronous timing with respect to the output signal. There is a weak pull down on the output that pulls CLKOUT LOW when either the PWR_DWN or OE signal is LOW. This weak pull down can easily be overridden by another clock signal in designs where multiple clock signals share a signal path.

Multiple options for output selection, better power distribution layout, and controlled rise and fall times enable the CY2077 to

be used in applications that require low jitter and accurate reference frequencies.

EPROM Configuration Block

Table 2. EPROM Adjustable Features

EPROM Adjustable Features	
Adjust Freq.	Feedback counter value (P)
	Reference counter value (Q)
	Output divider selection
Duty cycle levels (TTL or CMOS)	
Power management mode (OE or PWR_DWN)	
Power management timing (synchronous or asynchronous)	

PLL Output Frequency

CY2077 contains a high-resolution PLL with 12-bit multiplier and 10-bit divider.^[2] The output frequency of the PLL is determined by the following formula:

$$F_{PLL} = \frac{2 \cdot (P + 5)}{(Q + 2)} \cdot F_{REF}$$

where P is the feedback counter value and Q is the reference counter value. P and Q are EPROM programmable values.

The calculation of P and Q values for a given PLL output frequency is handled by the CyberClocks™ software. Refer to “Programming Procedures” on page 12” for details.

Note

- When using CyClocks, note that the PLL frequency range is from 50 MHz to 250 MHz for 5V V_{DD} supply, and 50 MHz to 180 MHz for 3V V_{DD} supply. The output frequency is determined by the selected output divider.

Power Management Features

PWR_DWN and OE options are configurable by EPROM programming for the CY2077. In PWR_DWN mode, all active circuits are powered down when the control pin is set LOW. When the control pin is set back HIGH, both the PLL and oscillator circuit must relock. In the case of OE, the output is three-stated and weakly pulled down when the control pin is set LOW. The oscillator and PLL are still active in this state, which leads to a quick clock output return when the control pin is set back HIGH.

Additionally, PWR_DWN and OE can be configured to occur asynchronously or synchronously with respect to CLKOUT. In asynchronous mode, PWR_DWN or OE disables CLKOUT immediately (allowing for logic delays), without respect to the current state of CLKOUT. Synchronous mode prevents output glitches by waiting for the next falling edge of CLKOUT after PWR_DWN, or OE becomes asserted. In either asynchronous or synchronous setting, the output is always enabled synchronously by waiting for the next falling edge of CLKOUT.

Table 3. Device Functionality: Output Frequencies

Symbol	Description	Condition	Min	Max	Unit
Fo	Output frequency	V _{DD} = 4.5–5.5V	0.39	133	MHz
		V _{DD} = 3.0–3.6V	0.39	100	MHz

Absolute Maximum Ratings

Exceeding maximum ratings may shorten the useful life of the device. User guidelines are not tested.

Supply voltage –0.5 to +7.0V

Input voltage –0.5V to V_{DD} +0.5V

Storage temperature (non-condensing)..... –55°C to +150°C

Junction temperature..... 150°C

Static discharge voltage..... ≥ 2000V
(per MIL-STD-883, method 3015)

Operating Conditions for Commercial Temperature Device

Parameter	Description	Min	Max	Unit
V _{DD}	Supply voltage	3.0	5.5	V
T _A	Operating temperature, ambient	0	+70	°C
C _{TTL}	Max. capacitive load on outputs for TTL levels			
	V _{DD} = 4.5 – 5.5V, output frequency = 1 – 40 MHz		50	pF
	V _{DD} = 4.5 – 5.5V, output frequency = 40 – 125 MHz		25	pF
	V _{DD} = 4.5 – 5.5V, output frequency = 125 – 133 MHz		15	pF
C _{CMOS}	Max. capacitive load on outputs for CMOS levels			
	V _{DD} = 4.5 – 5.5V, output frequency = 1 – 40 MHz		50	pF
	V _{DD} = 4.5 – 5.5V, output frequency = 40 – 125 MHz		25	pF
	V _{DD} = 4.5 – 5.5V, output frequency = 125 – 133 MHz		15	pF
	V _{DD} = 3.0 – 3.6V, output frequency = 1 – 40 MHz		30	pF
	V _{DD} = 3.0 – 3.6V, output frequency = 40 – 100 MHz		15	pF
X _{REF}	Reference frequency, input crystal with C _{load} = 10 pF	10	30	MHz
	Reference frequency, external clock source	1	75	MHz
t _{PU}	Power up time for all VDD's to reach minimum specified voltage (power ramps must be monotonic)	0.05	50	ms

Electrical Characteristics
 $T_A = 0^{\circ}\text{C to } +70^{\circ}\text{C}$

Parameter	Description	Test Conditions	Min	Typ	Max	Unit
V_{IL}	Low-level input voltage	$V_{DD} = 4.5 - 5.5\text{V}$ $V_{DD} = 3.0 - 3.6\text{V}$			0.8 $0.2V_{DD}$	V V
V_{IH}	High-level input voltage	$V_{DD} = 4.5 - 5.5\text{V}$ $V_{DD} = 3.0 - 3.6\text{V}$	2.0 $0.7V_{DD}$			V V
V_{OL}	Low-level output voltage	$V_{DD} = 4.5 - 5.5\text{V}, I_{OL} = 16\text{ mA}$ $V_{DD} = 3.0 - 3.6\text{V}, I_{OL} = 8\text{ mA}$			0.4 0.4	V V
V_{OHCMOS}	High-level output voltage CMOS levels	$V_{DD} = 4.5 - 5.5\text{V}, I_{OH} = -16\text{ mA}$ $V_{DD} = 3.0 - 3.6\text{V}, I_{OH} = -8\text{ mA}$	$V_{DD} - 0.4$ $V_{DD} - 0.4$			V V
V_{OHTTL}	High-level output voltage TTL levels	$V_{DD} = 4.5 - 5.5\text{V}, I_{OH} = -8\text{ mA}$	2.4			V
I_{IL}	Input low current	$V_{IN} = 0\text{V}$			10	μA
I_{IH}	Input high current	$V_{IN} = V_{DD}$			5	μA
I_{DD}	Power supply current Unloaded	$V_{DD} = 4.5 - 5.5\text{V}$, output frequency $\leq 133\text{ MHz}$ $V_{DD} = 3.0 - 3.6\text{V}$, output frequency $\leq 100\text{ MHz}$			45 25	mA mA
$I_{DDS}^{[3]}$	Stand-by current (PD = 0)	$V_{DD} = 4.5 - 5.5\text{V}$ $V_{DD} = 3.0 - 3.6\text{V}$		25 10	100 50	μA
R_{UP}	Input pull up resistor	$V_{DD} = 4.5 - 5.5\text{V}, V_{IN} = 0\text{V}$ $V_{DD} = 4.5 - 5.5\text{V}, V_{IN} = 0.7V_{DD}$	1.1 50	3.0 100	8.0 200	$\text{M}\Omega$ $\text{k}\Omega$
I_{OE_CLKOUT}	CLKOUT pull down current	$V_{DD} = 5.0$		20		μA

Note

3. If external reference is used, it is required to stop the reference (set reference to LOW) during power down.

Output Clock Switching Characteristics Commercial

Over the Operating Range^[4]

Parameter	Description	Test Conditions	Min	Typ	Max	Unit
t_{1w}	Output duty cycle at 1.4V, V_{DD} = 4.5 – 5.5V $t_{1w} = t_{1A} \div t_{1B}$	1 – 40 MHz, $C_L \leq 50$ pF 40 – 125 MHz, $C_L \leq 25$ pF 125 – 133 MHz, $C_L \leq 15$ pF	45 45 45		55 55 55	% % %
t_{1x}	Output duty cycle at $V_{DD}/2$, V_{DD} = 4.5 – 5.5V $t_{1x} = t_{1A} \div t_{1B}$	1 – 40 MHz, $C_L \leq 50$ pF 40 – 125 MHz, $C_L \leq 25$ pF 125 – 133 MHz, $C_L \leq 15$ pF	45 45 45		55 55 55	% % %
t_{1y}	Output duty cycle at $V_{DD}/2$, V_{DD} = 3.0 – 3.6V $t_{1y} = t_{1A} \div t_{1B}$	1 – 40 MHz, $C_L \leq 30$ pF 40 – 100 MHz, $C_L \leq 15$ pF	45 40		55 60	% %
t_2	Output clock rise time	Between 0.8 – 2.0V, $V_{DD} = 4.5V - 5.5V$, $C_L = 50$ pF Between 0.8 – 2.0V, $V_{DD} = 4.5V - 5.5V$, $C_L = 25$ pF Between 0.8 – 2.0V, $V_{DD} = 4.5V - 5.5V$, $C_L = 15$ pF Between $0.2V_{DD} - 0.8V_{DD}$, $V_{DD} = 4.5V - 5.5V$, $C_L = 50$ pF Between $0.2V_{DD} - 0.8V_{DD}$, $V_{DD} = 3.0V - 3.6V$, $C_L = 30$ pF Between $0.2V_{DD} - 0.8V_{DD}$, $V_{DD} = 3.0V - 3.6V$, $C_L = 15$ pF			1.8 1.2 0.9 3.4 4.0 2.4	ns ns ns ns ns ns
t_3	Output clock fall time	Between 0.8V – 2.0V, $V_{DD} = 4.5V - 5.5V$, $C_L = 50$ pF Between 0.8 – 2.0V, $V_{DD} = 4.5V - 5.5V$, $C_L = 25$ pF Between 0.8 – 2.0V, $V_{DD} = 4.5V - 5.5V$, $C_L = 15$ pF Between $0.2V_{DD} - 0.8V_{DD}$, $V_{DD} = 4.5V - 5.5V$, $C_L = 50$ pF Between $0.2V_{DD} - 0.8V_{DD}$, $V_{DD} = 3.0V - 3.6V$, $C_L = 30$ pF Between $0.2V_{DD} - 0.8V_{DD}$, $V_{DD} = 3.0V - 3.6V$, $C_L = 15$ pF			1.8 1.2 0.9 3.4 4.0 2.4	ns ns ns ns ns ns
t_4	Startup time out of power down	PWR_DWN pin LOW to HIGH ^[5]		1	2	ms
t_{5a}	Power down delay time (synchronous setting)	PWR_DWN pin LOW to output LOW (T= period of output CLK)		T/2	T + 10	ns
t_{5b}	Power down delay time (asynchronous setting)	PWR_DWN pin LOW to output LOW		10	15	ns
t_6	Power up time	From power on ^[5]		1	2	ms
t_{7a}	Output disable time (synchronous setting)	OE pin LOW to output high-Z (T= period of output CLK)		T/2	T + 10	ns
t_{7b}	Output disable time (asynchronous setting)	OE pin LOW to output high-Z		10	15	ns
t_8	Output enable time (always synchronous enable)	OE pin LOW to HIGH (T= period of output CLK)		T	1.5T + 25ns	ns
t_9	Peak-to-peak period jitter	$V_{DD} = 3.0V - 3.6V, 4.5V - 5.5V, F_o > 33$ MHz, $V_{CO} > 100$ MHz $V_{DD} = 3.0V - 5.5V, F_o < 33$ MHz		80 0.3%	150 1%	ps % of F_o

Notes

- Not all parameters measured in production testing.
- Oscillator start time can not be guaranteed for all crystal types. This specification is for operation with AT cut crystals with ESR < 70Ω.

Operating Conditions for Industrial Temperature Device

Parameter	Description	Min	Max	Unit
V _{DD}	Supply voltage	3.0	5.5	V
T _A	Operating temperature, ambient	-40	+85	°C
C _{TTL}	Max. capacitive load on outputs for TTL levels V _{DD} = 4.5 – 5.5V, output frequency = 1 – 40 MHz V _{DD} = 4.5 – 5.5V, output frequency = 40 – 125 MHz V _{DD} = 4.5 – 5.5V, output frequency = 125 – 133 MHz		35 15 10	pF pF pF
C _{CMOS}	Max. capacitive load on outputs for CMOS levels V _{DD} = 4.5 – 5.5V, output frequency = 1 – 40 MHz V _{DD} = 4.5 – 5.5V, output frequency = 40 – 125 MHz V _{DD} = 4.5 – 5.5V, output frequency = 125 – 133 MHz V _{DD} = 3.0 – 3.6V, output frequency = 1 – 40 MHz V _{DD} = 3.0 – 3.6V, output frequency = 40 – 100 MHz		35 15 10 20 10	pF pF pF pF pF
X _{REF}	Reference frequency, input crystal with C _{load} = 10 pF	10	30	MHz
	Reference frequency, external clock source	1	75	MHz
t _{PU}	Power up time for all VDD's to reach minimum specified voltage (power ramps must be monotonic)	0.05	50	ms

Electrical Characteristics

T_A = -40°C to +85°C

Parameter	Description	Test Conditions	Min	Typ.	Max	Unit
V _{IL}	Low-level input voltage	V _{DD} = 4.5 – 5.5V			0.8	V
		V _{DD} = 3.0 – 3.6V			0.2V _{DD}	V
V _{IH}	High-level input voltage	V _{DD} = 4.5 – 5.5V	2.0			V
		V _{DD} = 3.0 – 3.6V	0.7V _{DD}			V
V _{OL}	Low-level output voltage	V _{DD} = 4.5 – 5.5V, I _{OL} = 16 mA			0.4	V
		V _{DD} = 3.0 – 3.6V, I _{OL} = 8 mA			0.4	V
V _{OHC}	High-level output voltage, CMOS levels	V _{DD} = 4.5 – 5.5V, I _{OH} = -16 mA	V _{DD} - 0.4			V
		V _{DD} = 3.0 – 3.6V, I _{OH} = -8 mA	V _{DD} - 0.4			V
V _{OHTTL}	High-level output voltage, TTL levels	V _{DD} = 4.5 – 5.5V, I _{OH} = -8 mA	2.4			V
I _{IL}	Input low current	V _{IN} = 0V			10	μA
I _{IH}	Input high current	V _{IN} = V _{DD}			5	μA
I _{DD}	Power supply current, Unloaded	V _{DD} = 4.5 – 5.5V, output frequency ≤ 133 MHz			45	mA
		V _{DD} = 3.0 – 3.6V, output frequency ≤ 100 MHz			25	mA
I _{DD} ^[3]	Stand-by current (PD = 0)	V _{DD} = 4.5 – 5.5V		25	100	μA
		V _{DD} = 3.0 – 3.6V		10	50	μA
R _{UP}	Input pull up resistor	V _{DD} = 4.5 – 5.5V, V _{IN} = 0V	1.1	3.0	8.0	MΩ
		V _{DD} = 4.5 – 5.5V, V _{IN} = 0.7V _{DD}	50	100	200	kΩ
I _{OE_CLKOUT}	CLKOUT pull down current	V _{DD} = 5.0		20		μA

Output Clock Switching Characteristics Industrial

 Over the Operating Range^[4]

Parameter	Description	Test Conditions	Min	Typ.	Max	Unit
t_{1w}	Output duty cycle at 1.4V, $V_{DD} = 4.5 - 5.5V$ $t_{1w} = t_{1A} \div t_{1B}$	1 – 40 MHz, $C_L \leq 35$ pF 40 – 125 MHz, $C_L \leq 15$ pF 125 – 133 MHz, $C_L \leq 10$ pF	45 45 45		55 55 55	% % %
t_{1x}	Output duty cycle at $V_{DD}/2$, $V_{DD} = 4.5 - 5.5V$ $t_{1x} = t_{1A} \div t_{1B}$	1 – 40 MHz, $C_L \leq 35$ pF 40 – 125 MHz, $C_L \leq 15$ pF 125 – 133 MHz, $C_L \leq 10$ pF	45 45 45		55 55 55	% % %
t_{1y}	Output duty cycle at $V_{DD}/2$, $V_{DD} = 3.0 - 3.6V$ $t_{1y} = t_{1A} \div t_{1B}$	1– 40 MHz, $C_L \leq 20$ pF 40 – 100 MHz, $C_L \leq 10$ pF	45 40		55 60	% %
t_2	Output clock rise time	Between 0.8 – 2.0V, $V_{DD} = 4.5V - 5.5V$, $C_L = 35$ pF Between 0.8 – 2.0V, $V_{DD} = 4.5V - 5.5V$, $C_L = 15$ pF Between 0.8 – 2.0V, $V_{DD} = 4.5V - 5.5V$, $C_L = 10$ pF Between $0.2V_{DD} - 0.8V_{DD}$, $V_{DD} = 4.5V - 5.5V$, $C_L = 35$ pF Between $0.2V_{DD} - 0.8V_{DD}$, $V_{DD} = 3.0V - 3.6V$, $C_L = 20$ pF Between $0.2V_{DD} - 0.8V_{DD}$, $V_{DD} = 3.0V - 3.6V$, $C_L = 10$ pF			1.8 1.2 0.9 3.4 4.0 2.4	ns ns ns ns ns ns
t_3	Output clock fall time	Between 0.8V – 2.0V, $V_{DD} = 4.5V - 5.5V$, $C_L = 35$ pF Between 0.8 – 2.0V, $V_{DD} = 4.5V - 5.5V$, $C_L = 15$ pF Between 0.8 – 2.0V, $V_{DD} = 4.5V - 5.5V$, $C_L = 10$ pF Between $0.2V_{DD} - 0.8V_{DD}$, $V_{DD} = 4.5V - 5.5V$, $C_L = 35$ pF Between $0.2V_{DD} - 0.8V_{DD}$, $V_{DD} = 3.0V - 3.6V$, $C_L = 20$ pF Between $0.2V_{DD} - 0.8V_{DD}$, $V_{DD} = 3.0V - 3.6V$, $C_L = 10$ pF			1.8 1.2 0.9 3.4 4.0 2.4	ns ns ns ns ns ns
t_4	Startup time out of Power down	PWR_DWN pin LOW to HIGH ^[5]		1	2	ms
t_{5a}	Power down delay time (synchronous setting)	PWR_DWN pin LOW to output LOW (T= period of output clk)		T/2	T+10	ns
t_{5b}	Power down delay time (asynchronous setting)	PWR_DWN pin LOW to output LOW		10	15	ns
t_6	Power up time	From power on ^[5]		1	2	ms
t_{7a}	Output Disable time (synchronous setting)	OE pin LOW to output high-Z (T= period of output clk)		T/2	T + 10	ns
t_{7b}	Output Disable time (asynchronous setting)	OE pin LOW to output high-Z		10	15	ns
t_8	Output Enable time (always synchronous enable)	OE pin LOW to HIGH (T = period of output clk)		T	1.5T + 25ns	ns
t_9	Peak-to-peak period jitter	$V_{DD} = 3.0V - 3.6V$, $4.5V - 5.5V$, $F_o > 33$ MHz, $V_{CO} > 100$ MHz $V_{DD} = 3.0V - 5.5V$, $F_o < 33$ MHz		80 0.3%	150 1%	ps % of F_o

Switching Waveforms

Figure 2. Duty Cycle Timing (t_{1w} , t_{1x} , t_{1y})

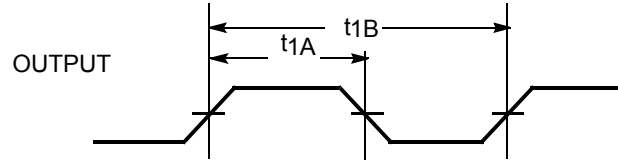

Figure 3. Output Rise/Fall Time

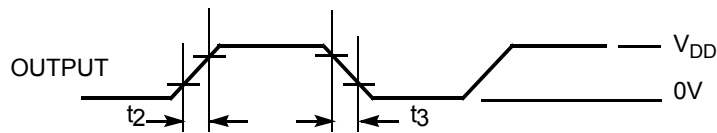

Figure 4. Power down Timing (synchronous and asynchronous modes)

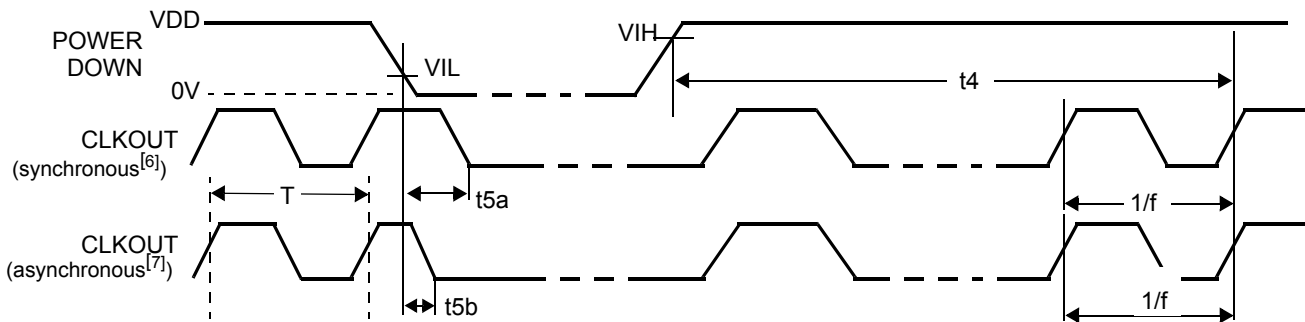

Figure 5. Power up Timing

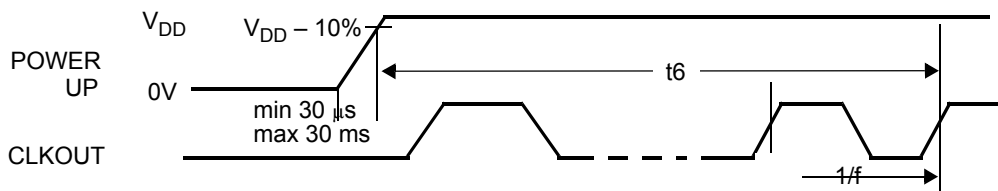
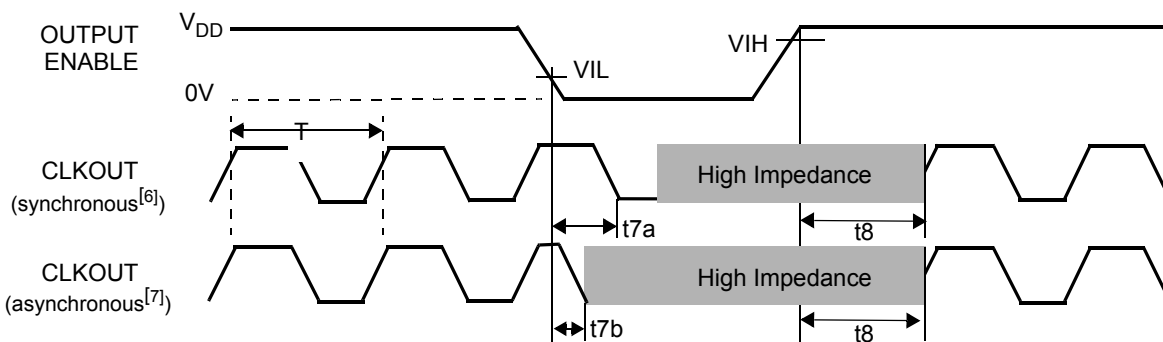

Figure 6. Output Enable Timing (synchronous and asynchronous modes)



Notes

- 6. In synchronous mode, the power down or output three-state is not initiated until the next falling edge of the output clock.
- 7. In asynchronous mode, the power down or output three-state occurs within 25 ns regardless of position in the output clock cycle.

Typical Rise/Fall Time^[8] Trends for CY2077

Figure 7. Rise/Fall Time vs. VDD over Temperatures

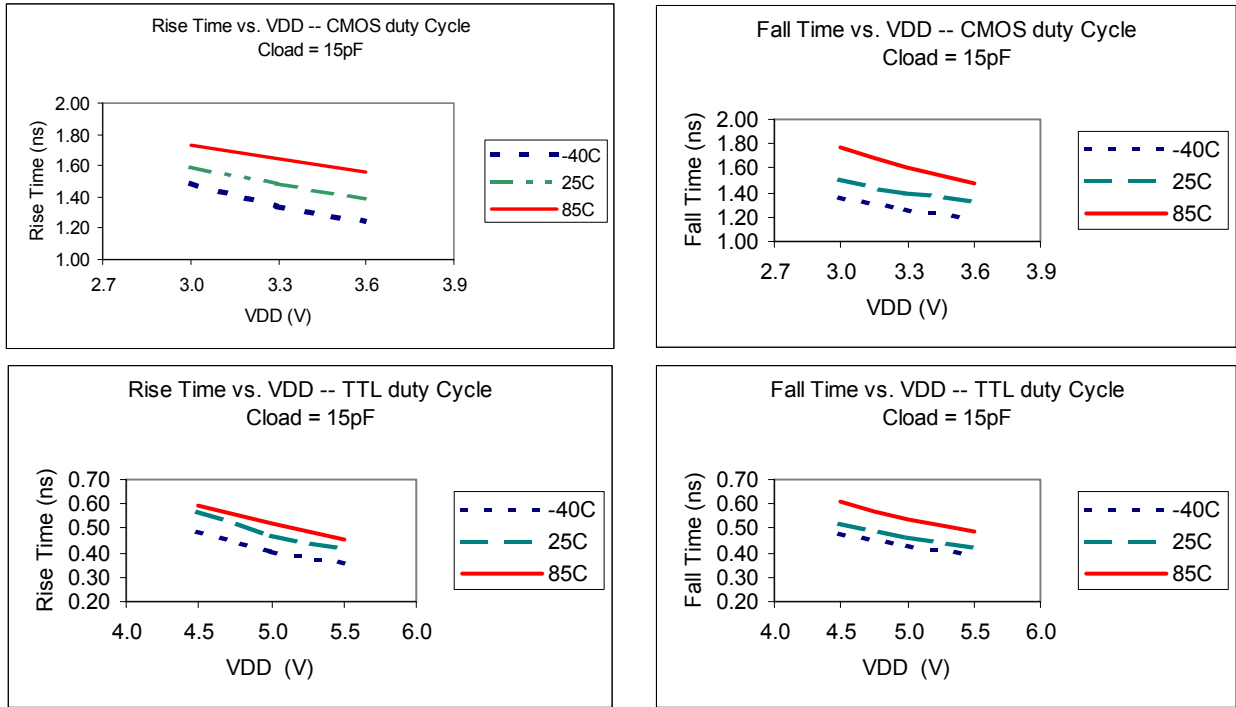
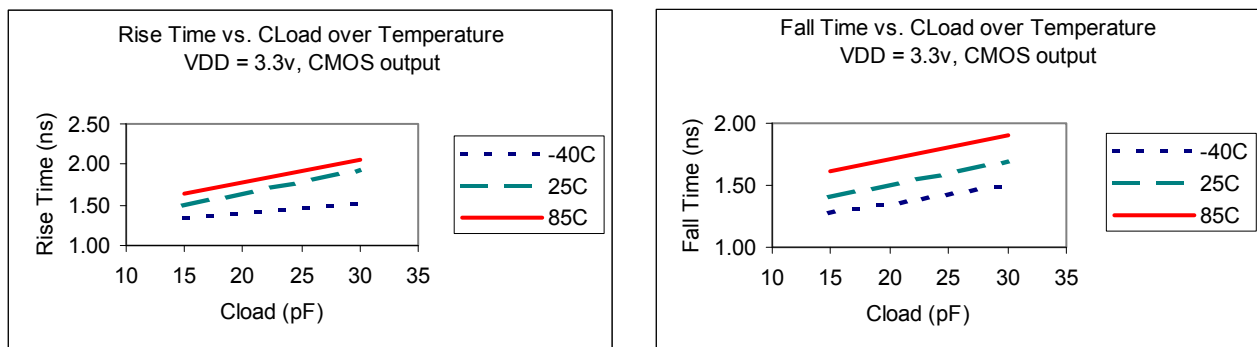

Figure 8. Rise/Fall Time vs. Output Loads over Temperatures



Note

8. Rise/Fall time for CMOS output is measured between 1.2 V_{DD} and 0.8 V_{DD}. Rise/Fall time for TTL output is measured between 0.8V and 2.0V.

Typical Duty Cycle^[9] Trends for CY2077

Figure 9. Duty Cycle vs. V_{DD} over Temperatures

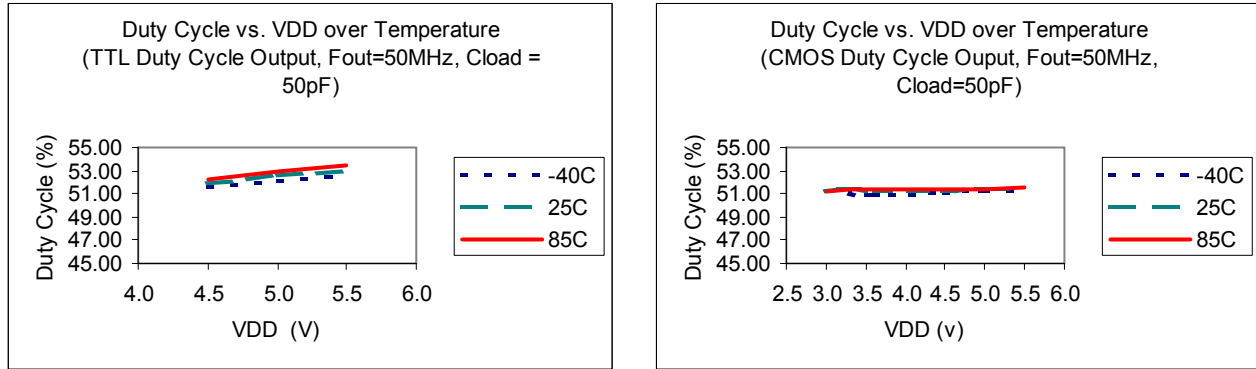

Figure 10. Duty Cycle vs. Output Load

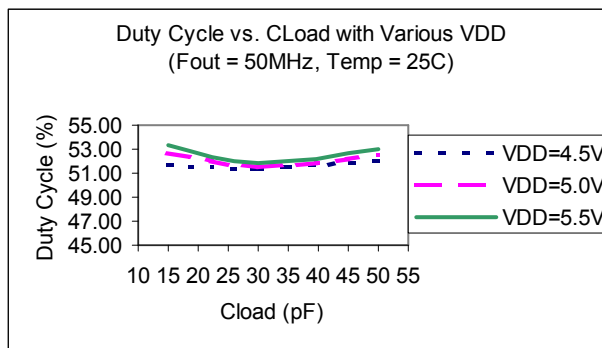
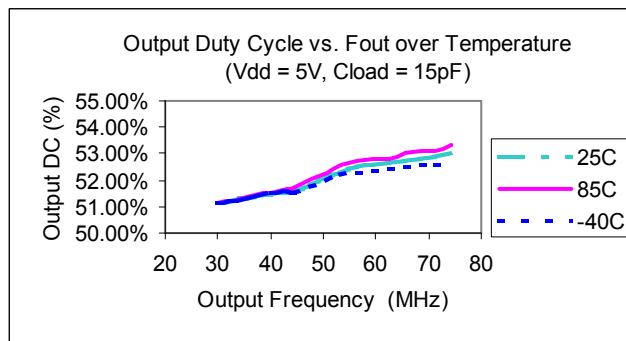

Figure 11. Duty Cycle vs. Output Frequency over Temperatures



Note

9. Duty cycle is measured at 1.4V for TTL output and 0.5 V_{DD} for CMOS output.

Typical Jitter Trends for CY2077

Figure 12. Period Jitter (pk-pk) vs. V_{DD} over Temperatures

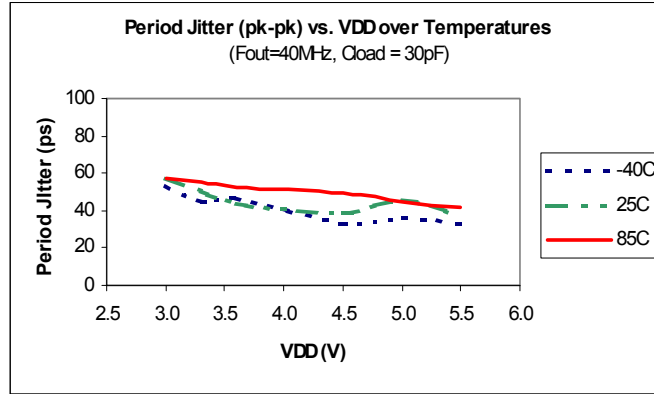
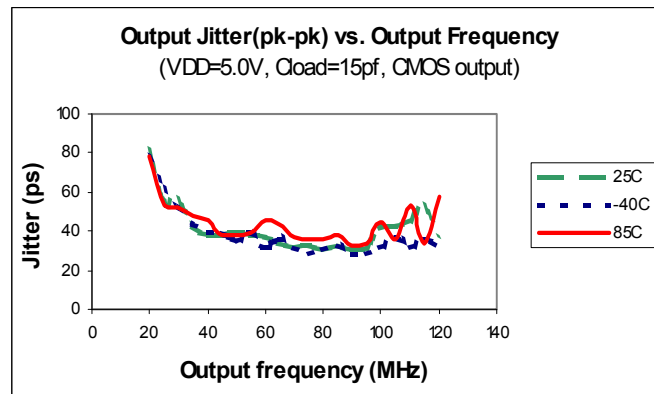
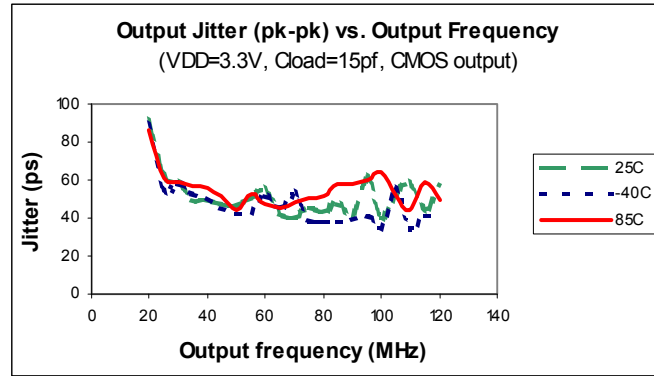

Figure 13. Period Jitter (pk-pk) vs. Output Frequency over Temperatures



Programming Procedures

Currently the CY2077 is available only as a field-programmable device, as indicated by an “F” in the ordering code.

Devices may be programmed using the CY3670 programmer, or through programmers available from third party programmer manufacturers such as Hi-Lo Systems and BP Micro. Programming services are also available from third parties, including some Cypress distribution partners.

To generate a JEDEC format programming file, customers must use CyClocks software. This software automatically calculates the output frequencies that can be generated by

CY2077 devices. The CyClocks software is a subset of the larger software tool CyberClocks, which is available free of charge from the Cypress web site (<http://www.cypress.com>). CyberClocks is installed on a PC and must not be confused with the web-based application CyberClocks Online.

For high volume designs, factory programming of customer-specific configurations is available on other 8-pin devices such as the CY22180, CY22801 and CY22381. Factory programming is no longer offered for new designs using the CY2077.

Ordering Information

Order Code ^[11]	Package Name	Package Type	Operating Temp. Range	Operating Voltage
Pb-Free				
CY2077FSXC	S8	8-pin SOIC	Commercial (T = 0°C to 70°C)	3.3V or 5V
CY2077FSXCT	S8	8-pin SOIC–Tape and Reel	Commercial (T = 0°C to 70°C)	3.3V or 5V
CY2077FZZ	Z8	8-pin TSSOP	Commercial (T = 0°C to 70°C)	3.3V or 5V
CY2077FZXI	Z8	8-pin TSSOP	Industrial (T = –40°C to 85°C)	3.3V or 5V
CY2077FZXIT	Z8	8-pin TSSOP–Tape and Reel	Industrial (T = –40°C to 85°C)	3.3V or 5V

Table 4. Obsolete or Not For New Designs

Original Device		Replacement Device	
Order Code ^[10, 11]	Description	Order Code	Description
CY2077SC-xxx		none	
CY2077SC-xxxT		none	
CY2077SI-xxx		none	
CY2077SI-xxxT		none	
CY2077SXC-xxx		none	
CY2077SXC-xxxT		none	
CY2077ZC-xxx		none	
CY2077ZC-xxxT		none	
CY2077ZI-xxx		none	
CY2077ZI-xxxT		none	
CY2077ZXC-xxx		none	
CY2077ZXC-xxxT		none	
CY2077FSI	SOIC, Industrial (T = –40°C to 85°C)	CY2077FSXC	Pb-free SOIC, Commercial
CY2077FZ	TSSOP, Commercial (T = 0°C to 70°C)	CY2077FZZ	Pb-free TSSOP, Commercial
CY2077FZI	TSSOP, Industrial (T = –40°C to 85°C)	CY2077FZXI	Pb-free TSSOP, Industrial

Notes

10. The CY2077SC-xxx(T), CY2077SI-xxx(T), CY2077SXC-xxx(T), CY2077ZC-xxx(T), CY2077ZI-xxx(T) and CY2077ZXC-xxx(T), are factory programmed configurations. Factory programming is available for high-volume design opportunities. For more details, contact your local Cypress FAE or Cypress Sales Representative.
11. The CY2077F are field programmable. For more details, contact your local Cypress FAE or Cypress Sales Representative.

Package Diagrams

Figure 14. 8-pin (150 mil Body) SOIC (Small Outline IC)

8 Lead (150 Mil) SOIC – S08

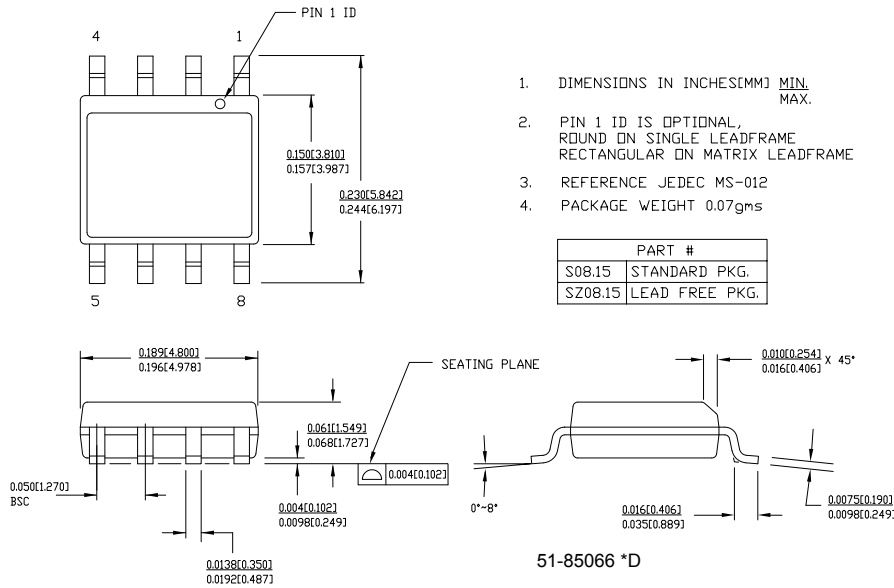
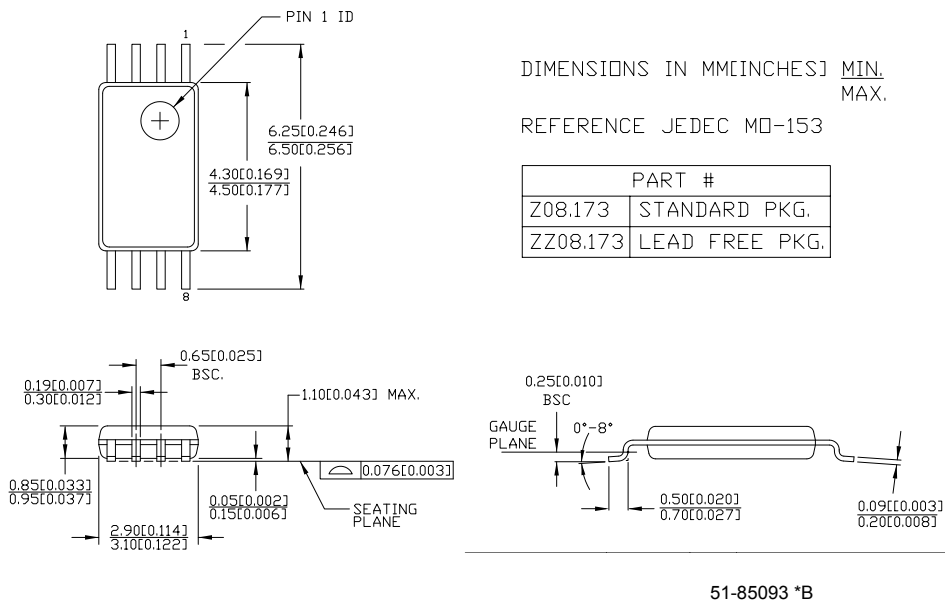

Figure 15. 8-pin (4.40-mm Body) TSSOP (Thin Shrunk Small Outline Package)

8 Lead TSSOP 4.40 MM BODY



Document History Page

Document Title: CY2077 High-accuracy EPROM Programmable Single-PLL Clock Generator Document Number: 38-07210				
REV.	ECN	Orig. of Change	Submission Date	Description of Change
**	111727	DSG	02/07/02	Convert from Spec number: 38-01009 to 38-07210
*A	114938	CKN	07/24/02	Added table and notes to page 11
*B	121843	RBI	12/14/02	Power up requirements added to Operating Conditions Information
*C	2104546	PYG/KVM /AESA	See ECN	Updated Ordering Information table Replaced the "Custom Configuration Request Procedure" section with "Programming Procedures" Updated package diagrams
*D	2631183	KVM/AESA	01/06/09	Updated template. CY2077FS removed from the active part number table. Added CY2077FZXI and CY2077FZXIT to the Ordering Information table. Corrected wording on p. 2 about when the weak output pull-down is active. Added to Table 1 to indicate that PWR_DWN is active low and OE is active high.
*E	2905892	CXQ	04/07/10	Removed inactive part CY2077FS from Table 4. Updated package diagrams.

Sales, Solutions, and Legal Information

Worldwide Sales and Design Support

Cypress maintains a worldwide network of offices, solution centers, manufacturer's representatives, and distributors. To find the office closest to you, visit us at cypress.com/sales.

Products

PSoC	psoc.cypress.com
Clocks & Buffers	clocks.cypress.com
Wireless	wireless.cypress.com
Memories	memory.cypress.com
Image Sensors	image.cypress.com

PSoC Solutions

General	psoc.cypress.com/solutions
Low Power/Low Voltage	psoc.cypress.com/low-power
Precision Analog	psoc.cypress.com/precision-analog
LCD Drive	psoc.cypress.com/lcd-drive
CAN 2.0b	psoc.cypress.com/can
USB	psoc.cypress.com/usb

© Cypress Semiconductor Corporation, 2002-2010. The information contained herein is subject to change without notice. Cypress Semiconductor Corporation assumes no responsibility for the use of any circuitry other than circuitry embodied in a Cypress product. Nor does it convey or imply any license under patent or other rights. Cypress products are not warranted nor intended to be used for medical, life support, life saving, critical control or safety applications, unless pursuant to an express written agreement with Cypress. Furthermore, Cypress does not authorize its products for use as critical components in life-support systems where a malfunction or failure may reasonably be expected to result in significant injury to the user. The inclusion of Cypress products in life-support systems application implies that the manufacturer assumes all risk of such use and in doing so indemnifies Cypress against all charges.

Any Source Code (software and/or firmware) is owned by Cypress Semiconductor Corporation (Cypress) and is protected by and subject to worldwide patent protection (United States and foreign), United States copyright laws and international treaty provisions. Cypress hereby grants to licensee a personal, non-exclusive, non-transferable license to copy, use, modify, create derivative works of, and compile the Cypress Source Code and derivative works for the sole purpose of creating custom software and/or firmware in support of licensee product to be used only in conjunction with a Cypress integrated circuit as specified in the applicable agreement. Any reproduction, modification, translation, compilation, or representation of this Source Code except as specified above is prohibited without the express written permission of Cypress.

Disclaimer: CYPRESS MAKES NO WARRANTY OF ANY KIND, EXPRESS OR IMPLIED, WITH REGARD TO THIS MATERIAL, INCLUDING, BUT NOT LIMITED TO, THE IMPLIED WARRANTIES OF MERCHANTABILITY AND FITNESS FOR A PARTICULAR PURPOSE. Cypress reserves the right to make changes without further notice to the materials described herein. Cypress does not assume any liability arising out of the application or use of any product or circuit described herein. Cypress does not authorize its products for use as critical components in life-support systems where a malfunction or failure may reasonably be expected to result in significant injury to the user. The inclusion of Cypress' product in a life-support systems application implies that the manufacturer assumes all risk of such use and in doing so indemnifies Cypress against all charges.

Use may be limited by and subject to the applicable Cypress software license agreement.