

Technical Data Sheet

3 ϕ Infrared Piranha

PIR3D-06C/L415

Features

- High reliability
- High total radiated power
- Peak wavelength $\lambda_p=730\text{nm}$
- Low forward voltage
- Pb free
- The product itself will remain within RoHS compliant version.



Descriptions

- EVERLIGHT'S Infrared Emitting Diode(PIR3D-06C/L415) is a high intensity diode , molded in a water clear plastic package.
- The device is spectrally matched with phototransistor , photodiode and infrared receiver module.

Applications

- Infrared applied system

Device Selection Guide

LED Part No.	Chip	Lens Color
	Material	
PIR3D-06C/L415	AlGaAs	Water Clear

Package Dimensions

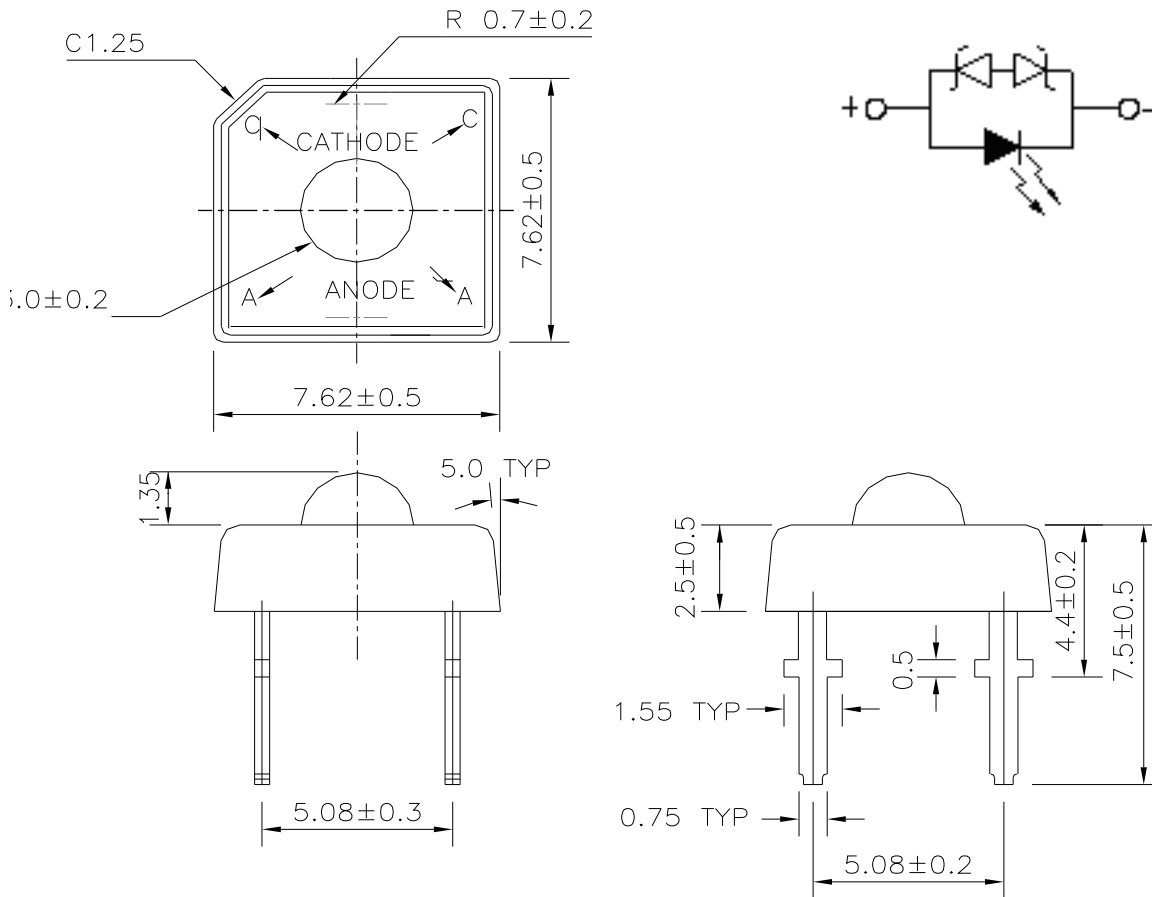

- Notes:**
1. All dimensions are in millimeters
 2. Tolerances unless dimensions ± 0.25 mm

Absolute Maximum Ratings (Ta=25°C)

Parameter	Symbol	Rating	Unit
Continuous Forward Current	I _F	150	mA
Peak Forward Current *1	I _{FP}	1.0	A
Reverse Voltage	V _R	5	V
Operating Temperature	T _{opr}	-40 ~ +85	°C
Storage Temperature	T _{stg}	-40 ~ +100	°C
Soldering Temperature*2	T _{sol}	260	°C
Power Dissipation at(or below) 25°C Free Air Temperature	P _d	450	mW

Notes: *1:I_{FP} Conditions--Pulse Width ≤ 100 μs and Duty ≤ 1%.

*2:Soldering time ≤ 5 seconds.

Electro-Optical Characteristics (Ta=25°C)

Parameter	Symbol	Condition	Min.	Typ.	Max.	Unit
Total Radiated Power	Φ _w	I _F =150mA	30	--	200	mW
Peak Wavelength	λ _p	I _F =150mA	715	730	745	nm
Spectral Bandwidth	Δλ	I _F =150mA	--	20	--	nm
Forward Voltage	V _F	I _F =150mA	---	2.40	2.90	V
Reverse Current	I _R	V _R =5V	--	--	10	μA
View Angle	2θ 1/2	I _F =150mA	--	125	--	deg

Note:

1. Tolerance of Total Radiated Power : ±11%
2. Tolerance of Peak Wavelength : ±1nm
3. Tolerance of Forward Voltage : ±0.1V

Bin Range of Total Radiated Power Power

Bin Code	Min.	Max.	Unit	Condition
1	30	50	mW	I _F =150mA
2	50	100		
3	100	150		

Note:

Tolerance of Radiometric Power: $\pm 11\%$ **Bin Range of Peak Wavelength**

Bin Code	Min.	Max.	Unit	Condition
A	715	725	nm	I _F =150mA
B	725	735		
C	735	745		
D	735	745		

Note:

Tolerance of Peak Wavelength: $\pm 1\text{nm}$ **Bin Range of Forward Voltage**

Bin Code	Min.	Max.	Unit	Condition
1	1.7	1.9	V	I _F =150mA
2	1.9	2.1		
3	2.1	2.3		
4	2.3	2.5		
5	2.5	2.7		
6	2.7	2.9		

Note:

Tolerance of Forward Voltage: $\pm 0.1\text{V}$

Typical Electro-Optical Characteristics Curves

Fig.1 Forward Current vs. Ambient Temperature

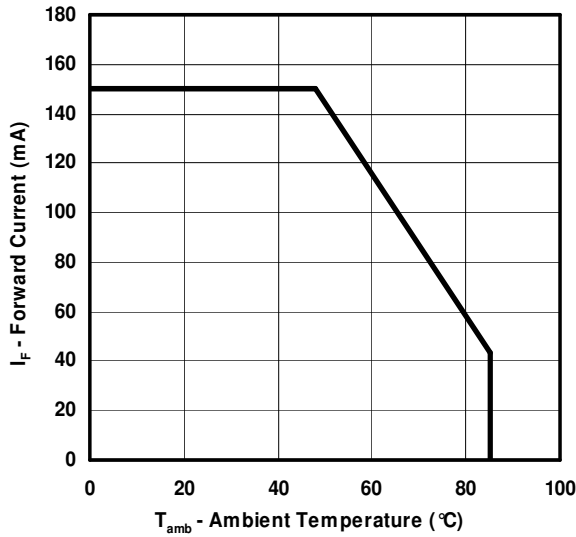

Fig.2 Spectral Distribution

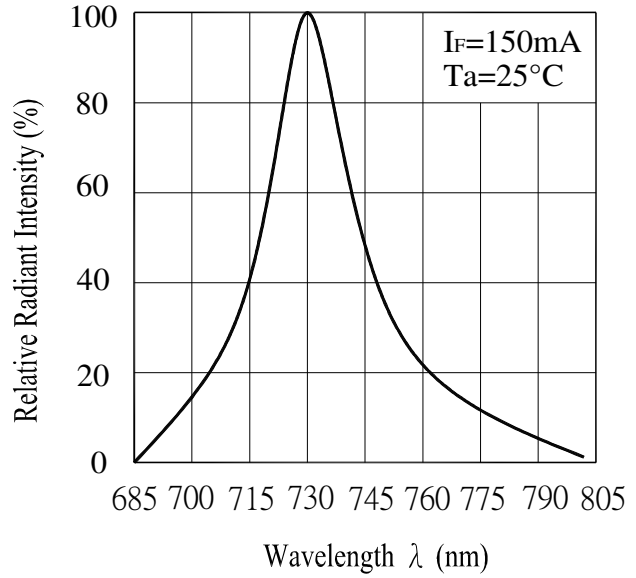

Fig.3 Relative Total Radiated Power vs. Forward Current (T_a=25°C)

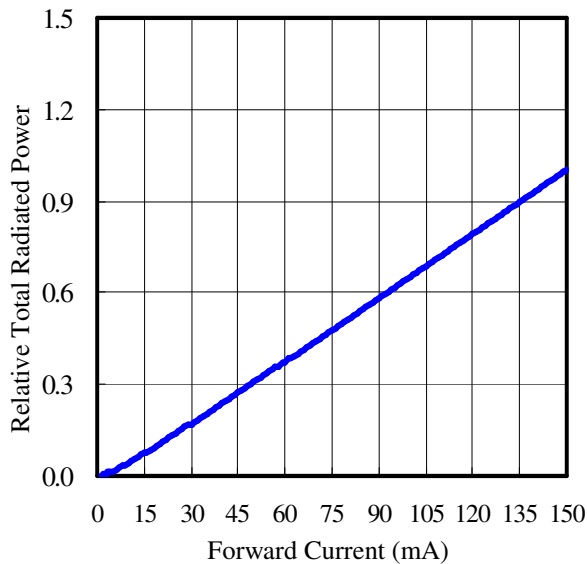
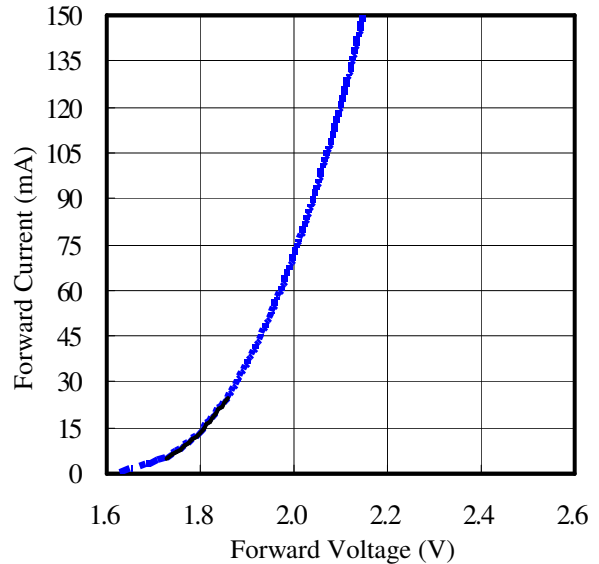
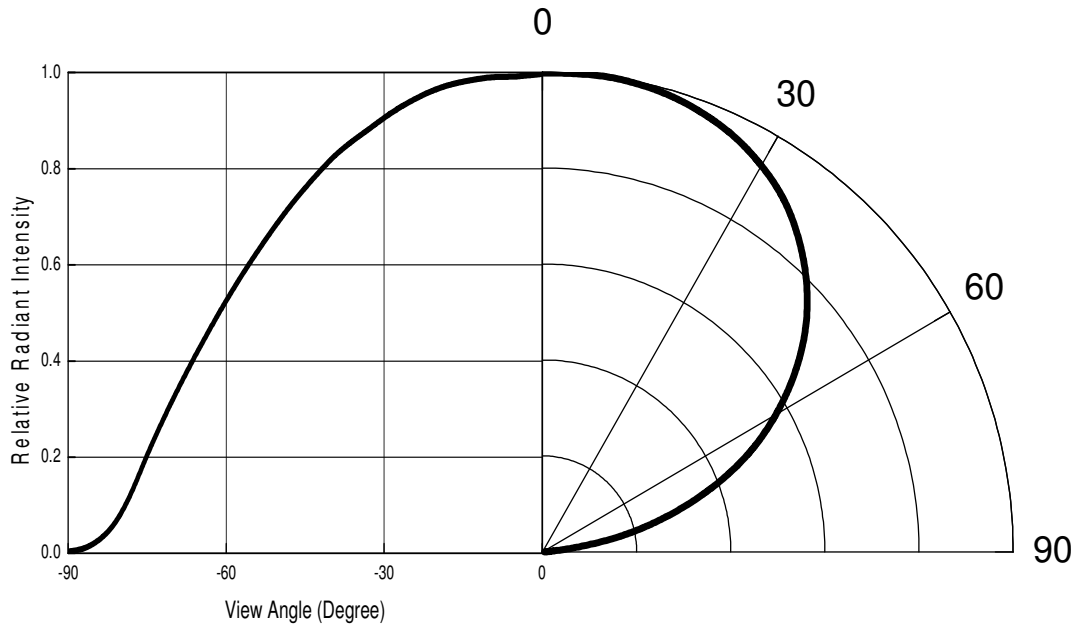

Fig.4 Forward Current vs. Forward Voltage



Typical Electro-Optical Characteristics Curves

Fig.6 Relative Radiant Intensity vs.
Angular Displacement



Moisture Resistant Packing Materials Tube

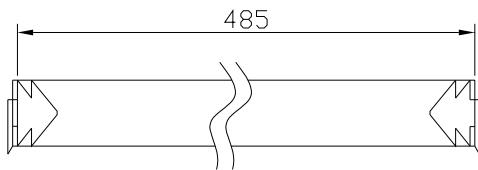
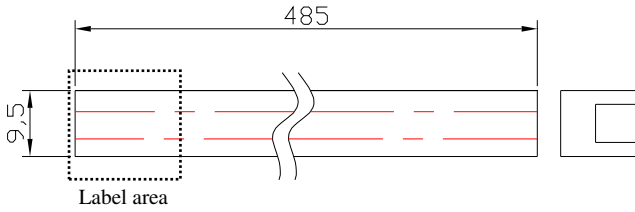

Note: Tolerances unless mentioned ± 2.0 mm. Unit = mm

	PART NO:	QTY:
	LOT NO:	CAT:

Tube Label Explanation

- PART NO: Product Number
- QTY: Packing Quantity
- LOT No: Lot Number
- CAT: Rank of (VF)(Note*)(ΦV)
Note: λ_d /CIE/Color temperature

Standard Box

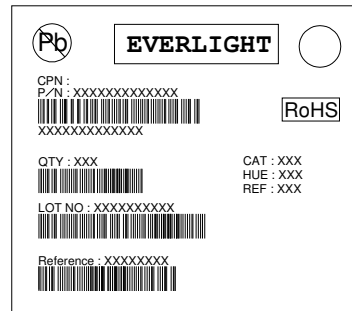
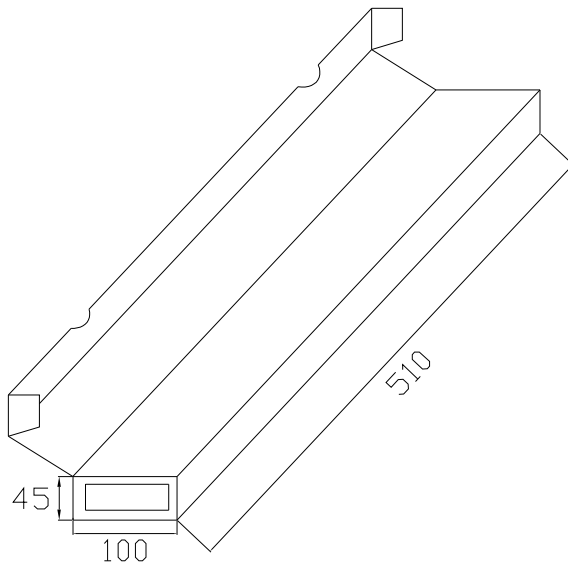

Tube Label Explanation

- CPN: Customer's Product Number
- P/N: Product Number
- QTY: Packing Quantity
- CAT: Rank of (Note*)
Note: λ_d /CIE/Color temperature
- Luminous Flux(Intensity)
- HUE/REF: Reference
- LOT No: Lot Number

Note: Tolerances unless mentioned ± 3.0 mm. Unit = mm

Packing Quantity

Packing material	Length × Width × height (mm)	Tube Quantity (Pcs)	LED Quantity (Pcs)
Tube	485 x 9.5 x 12	1	60
Standard box	510 x 100 x 45	30	1800
Large box	510 x 150 x 90	105	6300

Note:

1. Normal packing specification is use standard box, unless already defined initially.
2. Vacuum packing with anti-static bag after packing in standard box.
3. Specifications are subject to change without prior notice.

Notes

1. Lead Forming

- During lead formation, the leads should be bent at a point at least 3mm from the base of the epoxy bulb.
- Lead forming should be done before soldering.
- Avoid stressing the LED package during leads forming. The stress to the base may damage the LED's characteristics or it may break the LEDs.
- Cut the LED leadframes at room temperature. Cutting the leadframes at high temperatures may cause failure of the LEDs.
- When mounting the LEDs onto a PCB, the PCB holes must be aligned exactly with the lead position of the LED. If the LEDs are mounted with stress at the leads, it causes deterioration of the epoxy resin and this will degrade the LEDs.

2. Storage

- The LEDs should be stored at 30°C or less and 70%RH or less after being shipped from Everlight and the storage life limits are 3 months. If the LEDs are stored for 3 months or more, they can be stored for a year in a sealed container with a nitrogen atmosphere and moisture absorbent material.
- Please avoid rapid transitions in ambient temperature, especially, in high humidity environments where condensation can occur.

3. Soldering

- Careful attention should be paid during soldering. Solder the LED no lower than 1.6mm from the base of stopper is recommended.
- Avoiding applying any stress to the lead frame while the LEDs are at high temperature particularly when soldering.
- Recommended soldering conditions:

Hand Soldering		DIP Soldering	
Temp. at tip of iron	300°C Max. (30W Max.)	Preheat temp.	100°C Max. (60 sec Max.)
Soldering time	3 sec Max.	Bath temp.	260 Max.
Distance	No lower than 1.6mm from the base of stopper	Bath time.	5 sec Max.
		Distance	No lower than 1.6mm from the base of stopper

PIR3D-06C/L415

- Dip and hand soldering should not be done more than one time.
- After soldering the LEDs, the epoxy bulb should be protected from mechanical shock or vibration until the LEDs return to room temperature.
- A rapid-rate process is not recommended for cooling the LEDs down from the peak temperature.
- Although the recommended soldering conditions are specified in the above table, dip or handsoldering at the lowest possible temperature is desirable for the LEDs.
- Wave soldering parameter must be set and maintain according to recommended temperature and dwell time in the solder wave.

4. Circuit Protection

- Below the zener reference voltage V_z , all the current flows through LED and as the voltage rises to V_z , the zener diode “breakdown.” If the voltage tries to rise above V_z current flows through the zener branch to keep the voltage at exactly V_z .
- When the LED is connected using serial circuit, if either piece of LED is no light up but current can't flow through causing others to light down. In new design, the LED is parallel with zener diode. if either piece of LED is no light up but current can flow through causing others to light up.

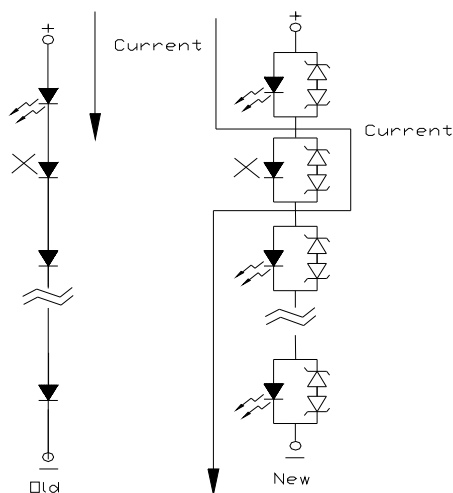

5. Cleaning

- When necessary, cleaning should occur only with isopropyl alcohol at room temperature for a duration of no more than one minute. Dry at room temperature before use.
- Do not clean the LEDs by the ultrasonic. When it is absolutely necessary, the influence of ultrasonic cleaning on the LEDs depends on factors such as ultrasonic power and the assembled condition. Ultrasonic cleaning shall be pre-qualified to ensure this will not cause damage to the LED

6. Heat Management

- Heat management of LEDs must be taken into consideration during the design stage of LED application. The current should be de-rated appropriately by referring to the de-rating curve found in each product specification.
- The temperature surrounding the LED in the application should be controlled. Please refer to the data sheet de-rating curve.

7. ESD (Electrostatic Discharge)

- Electrostatic discharge (ESD) or surge current (EOS) can damage LEDs.
- An ESD wrist strap, ESD shoe strap or antistatic gloves must be worn whenever handling LEDs.
- All devices, equipment and machinery must be properly grounded.
- Use ion blower to neutralize the static charge which might have built up on surface of the LEDs plastic lens as a result of friction between LEDs during storage and handing.

8. Other

- Above specification may be changed without notice. EVERLIGHT will reserve authority on material change for above specification.
- When using this product, please observe the absolute maximum ratings and the instructions for using outlined in these specification sheets. EVERLIGHT assumes no responsibility for any damage resulting from use of the product which does not comply with the absolute maximum ratings and the instructions included in these specification sheets.
- These specification sheets include materials protected under copyright of EVERLIGHT corporation. Please don't reproduce or cause anyone to reproduce them without EVERLIGHT's consent.