

SPECIFICATION FOR APPROVAL



Gleichmann & Co. Electronics GmbH
Product Marketing Displays & Systems
Schraderstr. 44, D- 67227 Frankenthal
Tel : +49 7249-910-0, Fax: +49 7249-910-559
display@msc-ge.com, <http://www.msc-ge.com>

- () Preliminary Specification
- (◆) Final Specification

Title	30" WQXGA TFT LCD
-------	--------------------------

BUYER	
MODEL	

SUPPLIER	LG Display Co., Ltd.
*MODEL	LM300WQ5
SUFFIX	STA1

*When you obtain standard approval,
please use the above model name without suffix

APPROVED BY	SIGNATURE DATE
/	_____
/	_____
/	_____

APPROVED BY	SIGNATURE DATE
S.D.Jung / Team Manager	_____
REVIEWED BY	
J.P.Kim / Project Manager	_____
PREPARED BY	
K.H.Han / Engineer	_____

Please return 1 copy for your confirmation with
your signature and comments.

**Mobile Engineering Dept.
LG Display**

CONTENTS

NO.	ITEM	Page
-	COVER	1
-	CONTENTS	2
-	RECORD OF REVISIONS	3
1	GENERAL DESCRIPTION	4
2	ABSOLUTE MAXIMUM RATINGS	5
3	ELECTRICAL SPECIFICATIONS	6
3-1	ELECTRICAL CHARACTERISTICS	6
3-2	INTERFACE CONNECTIONS	8
3-3	SIGNAL TIMING SPECIFICATIONS	12
3-4	SIGNAL TIMING WAVE FORMS	14
3-5	COLOR INPUT DATA REFERANCE	15
3-6	POWER SEQUENCE	16
4	OPTICAL SPECIFICATIONS	18
5	MECHANICAL CHARACTERISTICS	23
6	RELIABILITY	26
7	INTERNATIONAL STANDARDS	27
7-1	SAFETY	27
7-2	EMC	27
8	PACKING	28
8-1	DESIGNATION OF LOT MARK	28
8-2	PACKING FORM	28
9	PRECAUTIONS	29

Product Specification

1. General Description

The LM300WQ5 LCD is a Color Active Matrix Liquid Crystal Display with an integral Cold Cathode Fluorescent Lamp(CCFL) back light system. The matrix employs a-Si Thin Film Transistor as the active element. It is a transmissive type display operating in the normally black mode. This TFT-LCD has a 30.0 inch diagonally measured active display area with WQXGA resolution(2560 vertical by 1600 horizontal pixel array). Each pixel is divided into Red, Green and Blue sub-pixels or dots which are arranged in vertical stripes. Gray scale or the luminance of the sub-pixel color is determined with a 8-bit gray scale signal for each dot, thus, presenting a palette of more than 16,777,216 colors.

The LM300WQ5 has been designed to apply the Dual TMDS™(Transition Minimized differential Signaling) as the interface method to enables a simple and low-cost implementation in both the host and monitor.

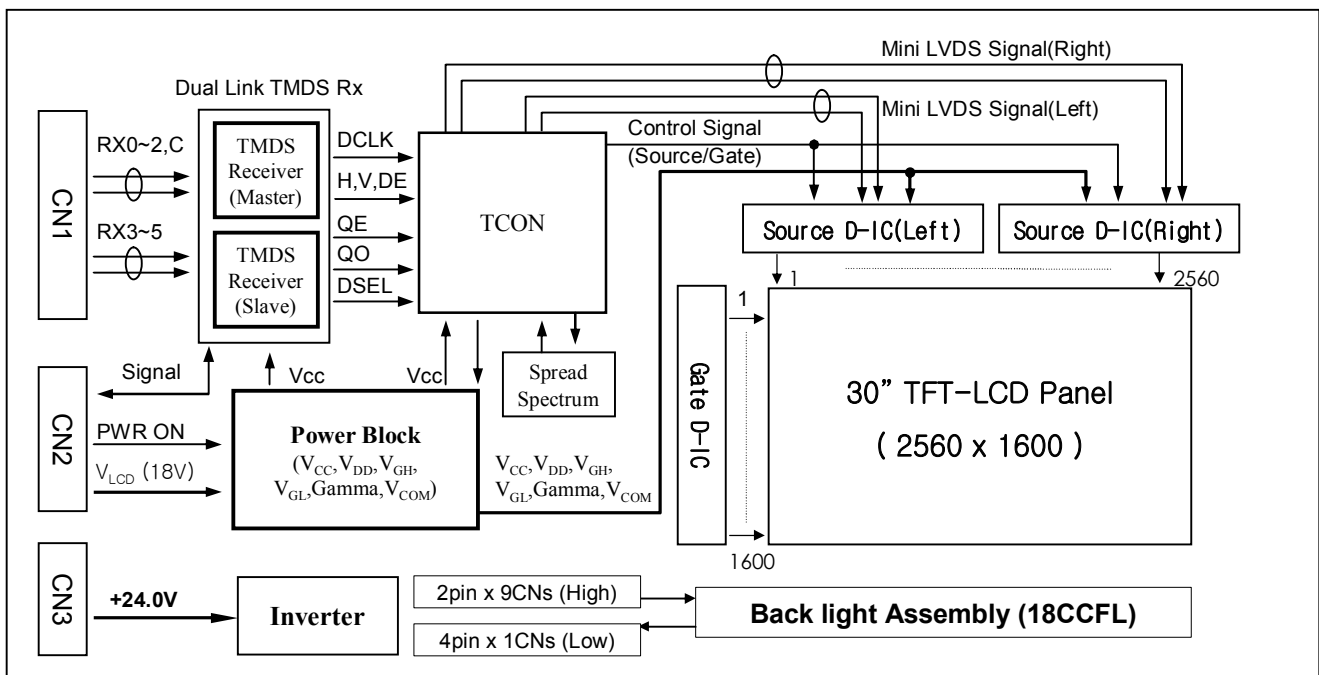

Figure 1. Block diagram

General Features

Active screen size	30.0 inches (756.228mm) diagonal
Outline Dimension	677.30(H) x 436.80(V) x 42.30(D) mm(Typ.)
Pixel Pitch	0.2505 mm x 0.2505 mm
Pixel Format	2560 horizontal By 1600 vertical Pixels. RGB stripe arrangement
Color Depth	8-bit, 16,777,216 color
Luminance, White	370 cd/m ² (1 point Center)
Viewing Angle(CR>10)	Viewing Angle Free(R/L 178(Typ.), U/D 178(Typ.))
Power Consumption	Total 123.00 Watt(Typ.), (15.00 Watt @V _{LCD} , 108W @370cd/)
Weight	5100 g (Typ.)
Display Operating Mode	Transmissive mode, normally Black
Surface Treatments	Hard coating (3H), Anti-glare treatment of the front polarizer

Product Specification

2. Absolute Maximum Ratings

The following are maximum values which, if exceeded, may cause faulty operation or damage to the unit.

Table 1. Absolute Maximum Ratings

Parameter	Symbol	Values		Units	Notes
		Min.	Max.		
Power Supply Input Voltage for Panel	V_{LCD}	-0.3	21.0	V_{dc}	At 25°C ± 2°C 1
Operating Temperature	T_{OP}	0	50	°C	
Storage Temperature	T_{ST}	-20	60	°C	
Operating Ambient Humidity	H_{OP}	10	90	%RH	
Storage Humidity	H_{ST}	10	90	%RH	

Note : 1. Temperature and relative humidity range are shown in the figure below.
Wet bulb temperature should be 39 °C Max, and no condensation of water.

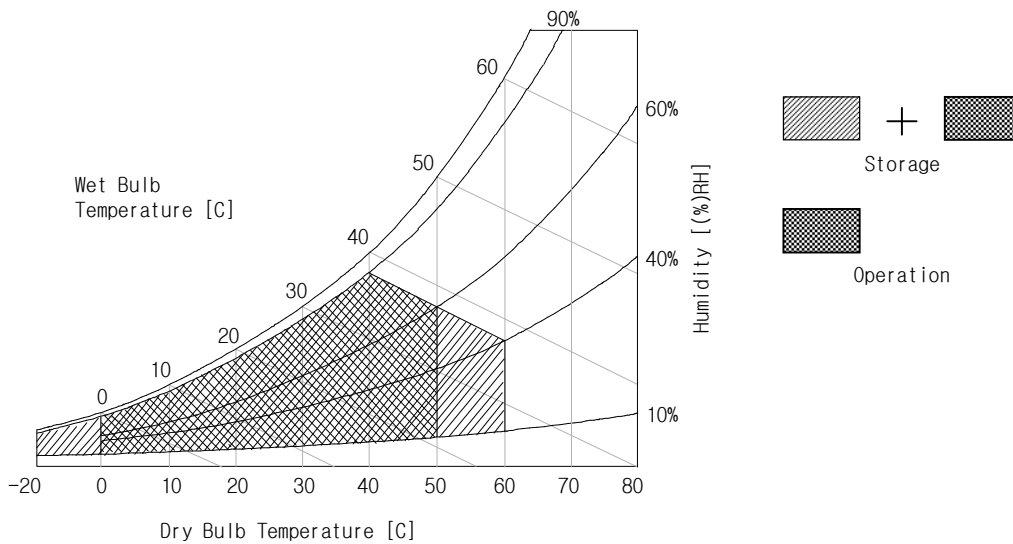

Figure 2. Temperature and relative humidity

Product Specification

3. Electrical Specifications

3-1. Electrical Characteristics

It requires two power inputs. One is employed to power the LCD electronics and to drive the TFT array and liquid crystal. The second input power for the CCFL, is typically generated by an inverter. The inverter is an external unit to the LCDs.

Table 2. Electrical Characteristics

Parameter	Symbol	Values			Unit	Notes
		Min	Typ	Max		
MODULE :						
Power Supply Input Voltage	V _{LCD}	17.0	18.0	19.0	Vdc	
Permissive Power Input Ripple	V _{dRF}			400	mV _{p-p}	
Power Supply Input Current	I _{LCD}	700	830	960	mA	1
		-	1080	1400	mA	2
Power Consumption	P _{LCD}	-	15.0	17.3	Watt	1
Rush current	I _{RUSH}	-	-	4	A	3

Note :

1. The specified current and power consumption are under the V_{LCD}=18.0V, 25 ± 2°C, f_V=60Hz condition whereas mosaic pattern(8 x 6) is displayed and f_V is the frame frequency.
2. The current is specified at the maximum current pattern.
3. The duration of rush current is about 2ms and rising time of power Input is 1ms(min.).

White : 255Gray
Black : 0Gray

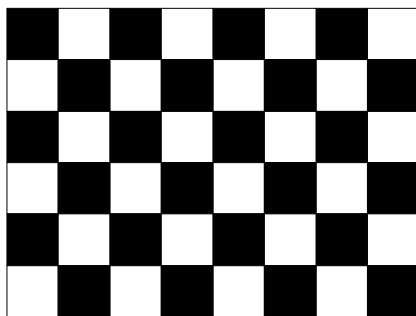

Mosaic Pattern(8 x 6)

Maximum current pattern



White Pattern

[Figure 3] Mosaic pattern : for power consumption measurement

Table 3. INVERTER Electrical Characteristics

Parameter	Symbol	Condition	Values			Unit	Notes
			Min.	Typ.	Max.		
Inverter :							
Input Voltage	V_{BL}		21.6	24.0	26.4	V	1
Input Current	I_{BL}	$V_{BR} = 3.3V$		4.5	5.4	A	2
Input Power	PBL	$V_{BR} = 3.3V$		108	130	Watt	2
B/L on/off control	VON/OFF	Lamp ON = High	2.0	-	5.0	V	
		Lamp OFF =Low	0.0	-	0.8	V	
Brightness Adj	VBR		0	-	3.3	V	
LAMP :							
Life time			40,000			Hrs	3

Notes :

1. The input voltage ripple is limited below 400mVp-p.
2. The specified current and power consumption are under the typical supply Input voltage, 24V.
3. The life is determined as the time at which luminance of the lamp is 50% compared to that of initial value at the typical lamp current on condition of continuous operating at $25 \pm 2^{\circ}C$.
4. Electrical characteristics are determined after the unit has been 'ON' and stable for approximately 30min in a dark environment at $25^{\circ}C \pm 2^{\circ}C$.

Product Specification

3-2. Interface Connections

This LCD employs three kinds of interface connections. A 30-pin connector is used for TMDS signals from the host computer. A 20-pin connector is used for LCD module power and LCM controls signal from external monitor control circuits. And 14-pin connector is used for the inverter for backlight system.

3-2-1. Signal Interface

The Dual TMDS signal interface connector is KDF71G-30S-1H(manufactured by Hirose) or FI-XL30SSL-HF(manufactured by JAE) or equivalent.

The pin configuration for the 30 pin connector is shown in the table below.

Table 4. 30Pin Connector pin configuration(For Dual Link TMDS)

Pin No.	Symbol	Description	Pin No.	Symbol	Description
1	NC	NC	16	RxC-	TMDS negative differential output(Channel C for 3,4,5ch)
2	NC	NC	17	SHLD2	Shield for TMDS Channel 2
3	NC	NC	18	Rx2+	TMDS positive differential output(Channel 2)
4	NC	NC	19	Rx2-	TMDS negative differential output(Channel 2)
5	SHLD5	Shield for TMDS Channel 5	20	SHLD1	Shield for TMDS Channel 1
6	Rx5+	TMDS positive differential output(Channel 5)	21	Rx1+	TMDS positive differential output(Channel 1)
7	Rx5-	TMDS negative differential output(Channel 5)	22	Rx1-	TMDS negative differential output(Channel 1)
8	SHLD4	Shield for TMDS Channel 4	23	SHLD0	Shield for TMDS Channel 0
9	Rx4+	TMDS positive differential output(Channel 4)	24	Rx0+	TMDS positive differential output(Channel 0)
10	Rx4-	TMDS negative differential output(Channel 4)	25	Rx0-	TMDS negative differential output(Channel 0)
11	SHLD3	Shield for TMDS Channel 3	26	SHLDC1	Shield for TMDS Channel C
12	Rx3+	TMDS positive differential output(Channel 3)	27	RxC+	TMDS positive differential output(Channel C for 0,1,2 ch)
13	Rx3-	TMDS negative differential output(Channel 3)	28	RxC-	TMDS negative differential output(Channel C for 0,1,2ch)
14	SHLDC2	Shield for TMDS Channel C	29	NC	NC
15	RxC+	TMDS positive differential output(Channel C for 3,4,5 ch)	30	NC	NC

- Notes :
1. Interface Chips
: Si17189 x 1ea (Dual TMDS Receiver ,Silicon Image)
 2. Connector
 - 2.1 Connector(Receptacle) : KDF71G-30S-1H(Hirose) or FI-XL30SSL-HF(JAE) or Equivalent.
 - 2.2 Mating Connector(Plug) : FI-X30H and FI-X30HL or its equivalent.

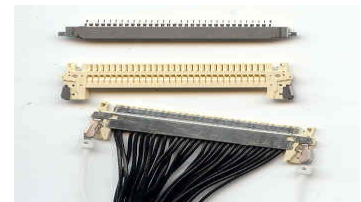

3-2-2.Power Connector

The power connector is FI-XL20S-HF or equivalent.

The pin configuration for the 20 pin connector is shown in the table below.

Table 5. 20Pin Connector pin configuration (Power Connector CN1)

Pin	Symbol	Description	Notes
1	NC	Reserved for I2C data	
2	NC	Reserved for I2C clock	
3	PWR_ON	LCM On signal input	
4	GND	ground	
5	GND	ground	
6	VLCD	18V	
7	VLCD	18V	
8	VLCD	18V	
9	GND	ground	
10	GND	ground	
11	HDCP_SCL	HDCP_I2C_Clock	
12	HDCP_SDA	HDCP_I2C_Data	
13	AGP	Auto pattern generation (NC/GND – no signal black)	
14	HS_OUT	Hsync output to scaler	
15	VS_OUT	Vsync output to scaler	
16	V_IC	5V logic voltage input for I2C	
17	ODC_ON	Reserved ODC on/off control (NC/HIGH – ODC ON)	
18	PWM_Vbr	PWM Vbr output for Inverter dimming	
19	NC	NC	
20	GND	ground	

Notes : 1. Connector

- 1) Connector(Receptacle) : DF19G-20P-1H or Equivalent.
- 2) Mating Connector(Plug) : DF19G-20S-1C or Equivalent.

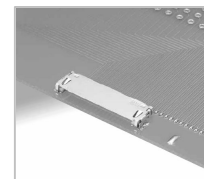

Product Specification

[Figure 4] Connector diagram

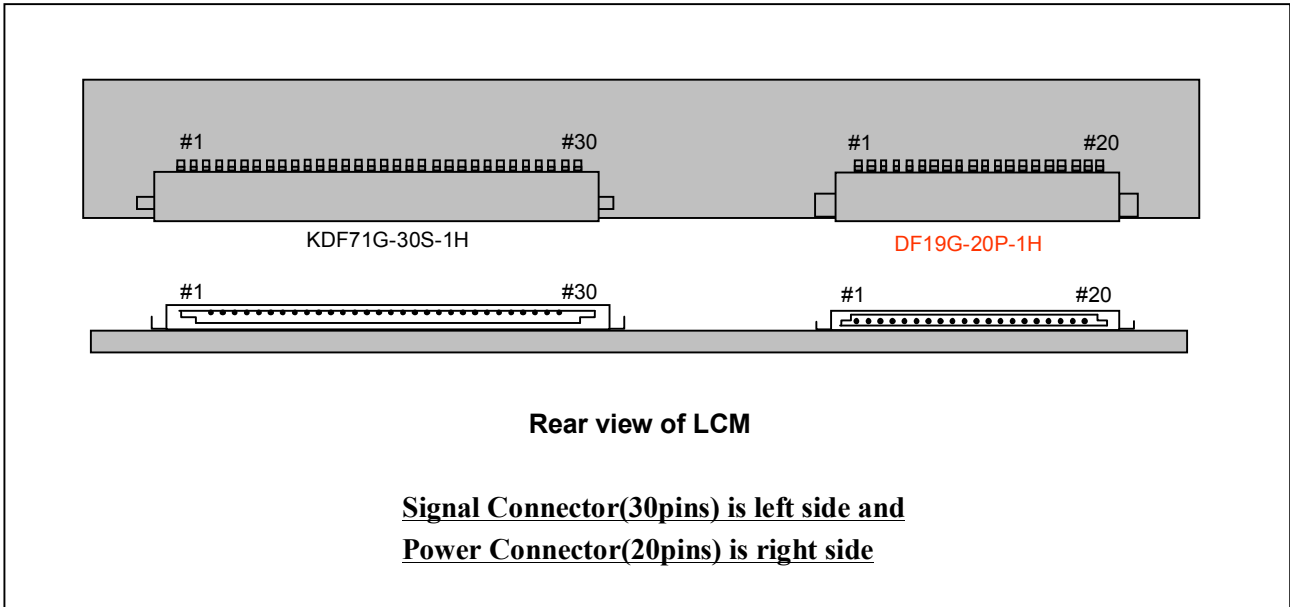

Notes:

1. All GND(ground) pins should be connected together and should also be connected to the LCD's metal frame.
2. All power input pins should be connected together.
3. All NC pins should be separated from other signal or power.

Product Specification

3-2-3. Inverter Connector for Backlight

The inverter connector is S14B-PH-SM3(manufactured by JST) or equivalent
The pin configuration for the 14 pin connector is shown in the table below.

Table 6. 14Pin Connector Pin Configuration (Inverter Connector)

Pin	Symbol	Description	Notes
1	V_{BL}	Power Supply, +24V	
2	V_{BL}	Power Supply, +24V	
3	V_{BL}	Power Supply, +24V	
4	V_{BL}	Power Supply, +24V	
5	V_{BL}	Power Supply, +24V	
6	GND	Power Ground	
7	GND	Power Ground	
8	GND	Power Ground	
9	GND	Power Ground	
10	GND	Power Ground	
11	VS	No connection	
12	V_{ON}	BL On/Off Control signal	ON : 2.0V~5.0V OFF : 0.0~0.8V
13	V_{BR}	PWM Dimming Control Signal	Max3.3V/Min0.0V
14	Status	Lamp Operating Status	Normal =0~0.8V Abnormal=3.0~5.0V

1. Connector

- 1) Connector(Receptacle) : S14B-PHA-SM3 (JST) or equivalent
- 2) Mating Connector(Plug) : PHR14 or its equivalent

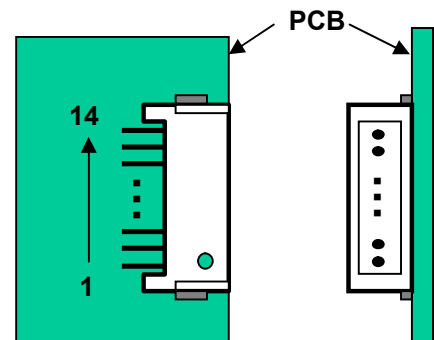

Rear view of LCM

Product Specification

3-3. Signal Timing Specifications

This is the signal timing required at the input of the TMDS Transmitter. All of the interface signal timing should be satisfied with the following specifications for its proper operation.

Table 7. TIMING TABLE 1 (Dual mode: 2560x1600)

PS ON : High

ITEM		SYMBOL	Min	Typ	Max	Unit	Note
DCLK	Period	t_{CLK}	7.45	7.45	7.45	ns	Pixel Frequency : Typ 268.5MHz
	Frequency	f_{CLK}	(133.25)	134.25	(135.25)	MHz	
Hsync	Width-Total	t_{HT}	2720	2720	2720	t_{CLK}	
	Period	t_{HP}	10.13	10.13	10.13	us	
	Frequency	f_H	98.71	98.71	98.71	KHz	
	Width	t_{WH}	32	32	32	t_{CLK}	
Vsync	Width-Total	t_{VT}	1646	1646	1646	t_{HP}	
	Period	t_{VP}	16.68	16.68	16.68		
	Frequency	f_V	59.97	59.97	59.97	Hz	
	Width	t_{WV}	6	6	6	t_{HP}	
Data Enable	Horizontal Valid	t_{HV}	2560	2560	2560	t_{CLK}	
	Horizontal Back Porch	t_{HBP}	80	80	80		
	Horizontal Front Porch	t_{HFP}	48	48	48		
	Horizontal Blank	-	160	160	160		$t_{WH} + t_{HBP} + t_{HFP}$
	Vertical Valid	t_{VV}	1600	1600	1600	t_{HP}	
	Vertical Back Porch	t_{VBP}	38	38	38		
	Vertical Front Porch	t_{VFP}	2	2	2		
	Vertical Blank	-	46	46	46		$t_{WV} + t_{VBP} + t_{VFP}$

Note: Hsync period and Hsync width-active should be even number times of t_{CLK} . If the value is odd number times of t_{CLK} , display control signal can be asynchronous. In order to operate this LCM a Hsync, Vsync, and DE(data enable) signals should be used.

1. : The performance of the electro-optical characteristics may be influenced by variance of the vertical refresh rates.
2. Vsync and Hsync should be keep the above specification.
3. Hsync Period, Hsync Width, and Horizontal Back Porch should be any times of of character number(8).
4. The polarity of Hsync, Vsync is not restricted.

3-4. Signal Timing Waveforms

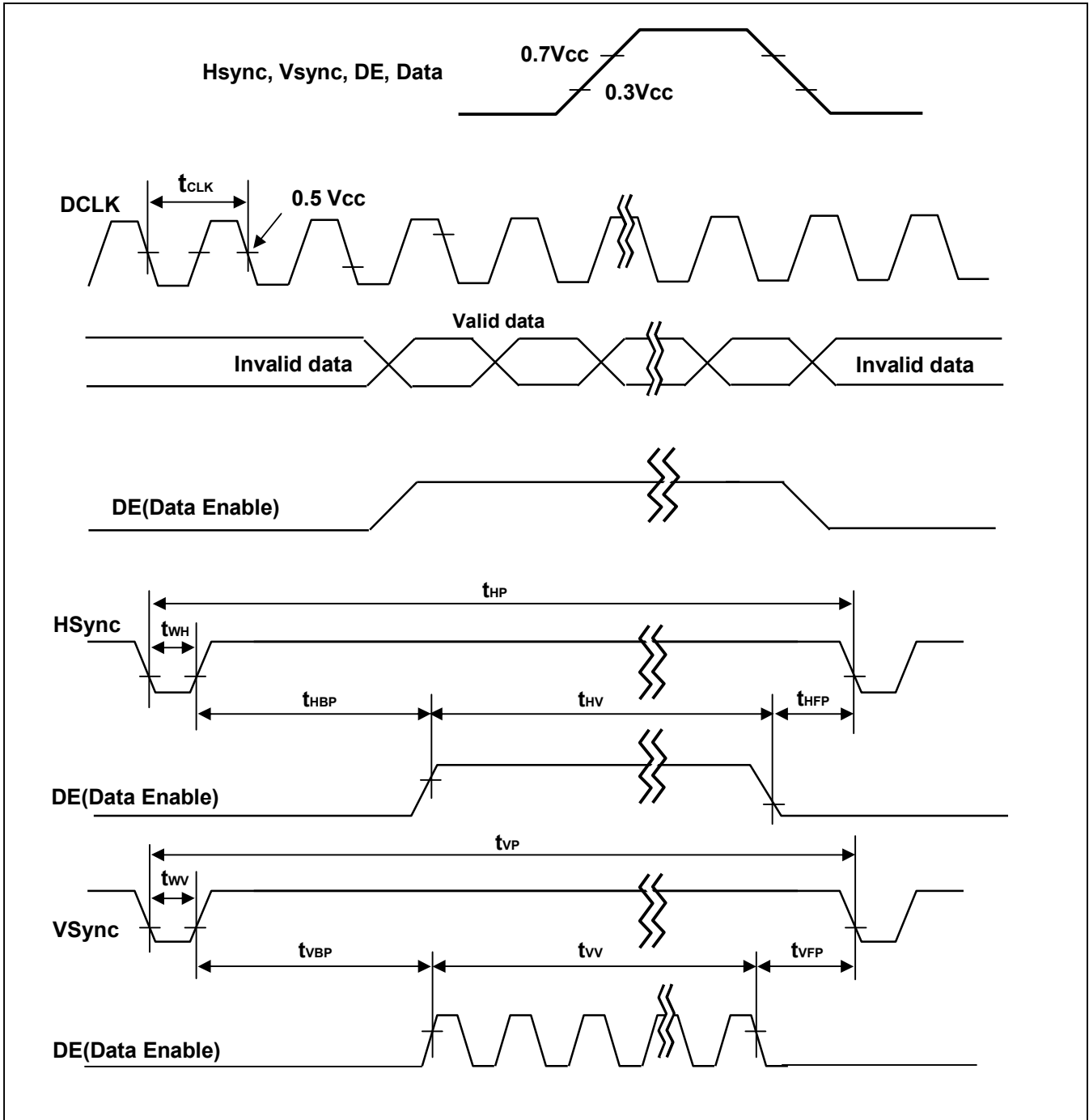

3-5. Color Input Data Reference

The brightness of each primary color (red, green and blue) is based on the 8-bit gray scale data input for the color ; the higher the binary input, the brighter the color. The table below provides a reference for color versus data input.

Table 9. COLOR DATA REFERENCE

Color		Input Color Data																							
		Red								Green								Blue							
		MSB				LSB				MSB				LSB				MSB				LSB			
		R7	R6	R5	R4	R3	R2	R1	R0	G7	G6	G5	G4	G3	G2	G1	G0	B7	B6	B5	B4	B3	B2	B1	B0
Basic Color	Black	0	0	0	0	0	0	0	0	0	0	0	0	0	0	0	0	0	0	0	0	0	0	0	0
	Red (255)	1	1	1	1	1	1	1	1	0	0	0	0	0	0	0	0	0	0	0	0	0	0	0	0
	Green (255)	0	0	0	0	0	0	0	0	1	1	1	1	1	1	1	1	0	0	0	0	0	0	0	0
	Blue (255)	0	0	0	0	0	0	0	0	0	0	0	0	0	0	0	0	1	1	1	1	1	1	1	1
	Cyan	0	0	0	0	0	0	0	0	1	1	1	1	1	1	1	1	1	1	1	1	1	1	1	1
	Magenta	1	1	1	1	1	1	1	1	0	0	0	0	0	0	0	0	1	1	1	1	1	1	1	1
	Yellow	1	1	1	1	1	1	1	1	1	1	1	1	1	1	1	1	0	0	0	0	0	0	0	0
	White	1	1	1	1	1	1	1	1	1	1	1	1	1	1	1	1	1	1	1	1	1	1	1	1
Red	Red(000) Dark	0	0	0	0	0	0	0	0	0	0	0	0	0	0	0	0	0	0	0	0	0	0	0	0
	Red(001)	0	0	0	0	0	0	0	1	0	0	0	0	0	0	0	0	0	0	0	0	0	0	0	0
	Red(002)	0	0	0	0	0	0	1	0	0	0	0	0	0	0	0	0	0	0	0	0	0	0	0	0
	-----	-	-	-	-	-	-	-	-	-	-	-	-	-	-	-	-	-	-	-	-	-	-	-	-
	-----	-	-	-	-	-	-	-	-	-	-	-	-	-	-	-	-	-	-	-	-	-	-	-	-
	Red(253)	1	1	1	1	1	1	0	1	0	0	0	0	0	0	0	0	0	0	0	0	0	0	0	0
	Red(254)	1	1	1	1	1	1	1	0	0	0	0	0	0	0	0	0	0	0	0	0	0	0	0	0
Red(255) Bright	1	1	1	1	1	1	1	1	0	0	0	0	0	0	0	0	0	0	0	0	0	0	0	0	
Green	Green(000) Dark	0	0	0	0	0	0	0	0	0	0	0	0	0	0	0	0	0	0	0	0	0	0	0	0
	Green(001)	0	0	0	0	0	0	0	0	0	0	0	0	0	0	1	0	0	0	0	0	0	0	0	
	Green(002)	0	0	0	0	0	0	0	0	0	0	0	0	0	1	0	0	0	0	0	0	0	0	0	
	-----	-	-	-	-	-	-	-	-	-	-	-	-	-	-	-	-	-	-	-	-	-	-	-	
	-----	-	-	-	-	-	-	-	-	-	-	-	-	-	-	-	-	-	-	-	-	-	-	-	
	Green(253)	0	0	0	0	0	0	0	0	1	1	1	1	1	1	0	1	0	0	0	0	0	0	0	
	Green(254)	0	0	0	0	0	0	0	0	1	1	1	1	1	1	1	0	0	0	0	0	0	0	0	
Green(255) Bright	0	0	0	0	0	0	0	0	1	1	1	1	1	1	1	1	0	0	0	0	0	0	0		
Blue	Blue(000) Dark	0	0	0	0	0	0	0	0	0	0	0	0	0	0	0	0	0	0	0	0	0	0	0	0
	Blue(001)	0	0	0	0	0	0	0	0	0	0	0	0	0	0	0	0	0	0	0	0	0	0	0	1
	Blue(002)	0	0	0	0	0	0	0	0	0	0	0	0	0	0	0	0	0	0	0	0	0	0	1	0
	-----	-	-	-	-	-	-	-	-	-	-	-	-	-	-	-	-	-	-	-	-	-	-	-	
	-----	-	-	-	-	-	-	-	-	-	-	-	-	-	-	-	-	-	-	-	-	-	-	-	
	Blue(253)	0	0	0	0	0	0	0	0	0	0	0	0	0	0	0	1	1	1	1	1	1	1	0	1
	Blue(254)	0	0	0	0	0	0	0	0	0	0	0	0	0	0	0	1	1	1	1	1	1	1	1	0
Blue(255) Bright	0	0	0	0	0	0	0	0	0	0	0	0	0	0	0	1	1	1	1	1	1	1	1	1	

Product Specification

3-6. Power Sequence for Panel

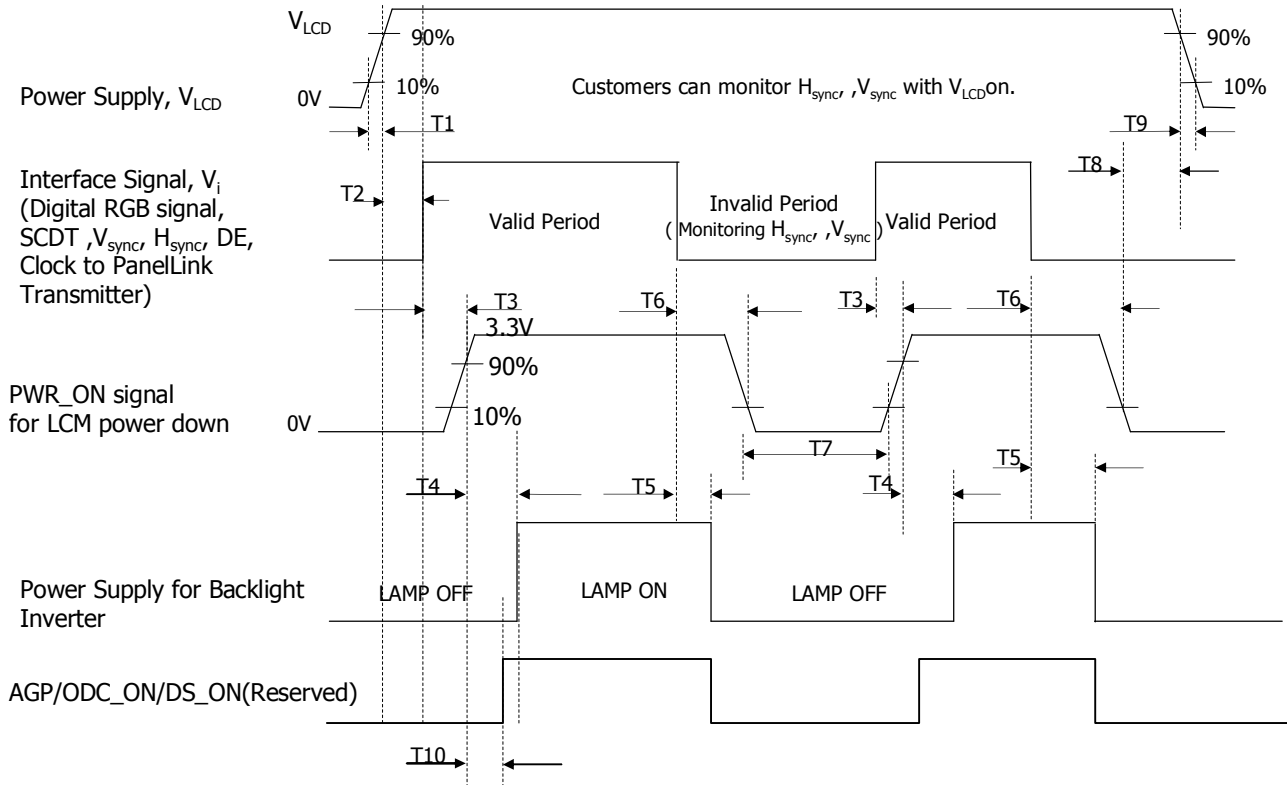

Table 10. Power Sequence

Parameter	Values			Units	Notes
	Min.	Typ.	Max.		
T1	-	-	30	ms	
T2	50	-	-	ms	
T3	-	-	300	ms	
T4	100	-	-	ms	
T5	-	-	T6	ms	
T6	-	-	-	ms	
T7	400	-	-	ms	
T8	50	-	-	ms	
T9	-	-	-	ms	
T10	50	-	-	ms	

- Notes :
1. Please avoid floating state of interface signal at invalid period.
 2. When the interface signal is invalid, be sure to pull down the power supply for LCD V_{LCD} to 0V.
 3. Lamp power must be turn on after power supply for LCD and interface signal are valid.

Product Specification

3-6. Power Sequence for Inverter

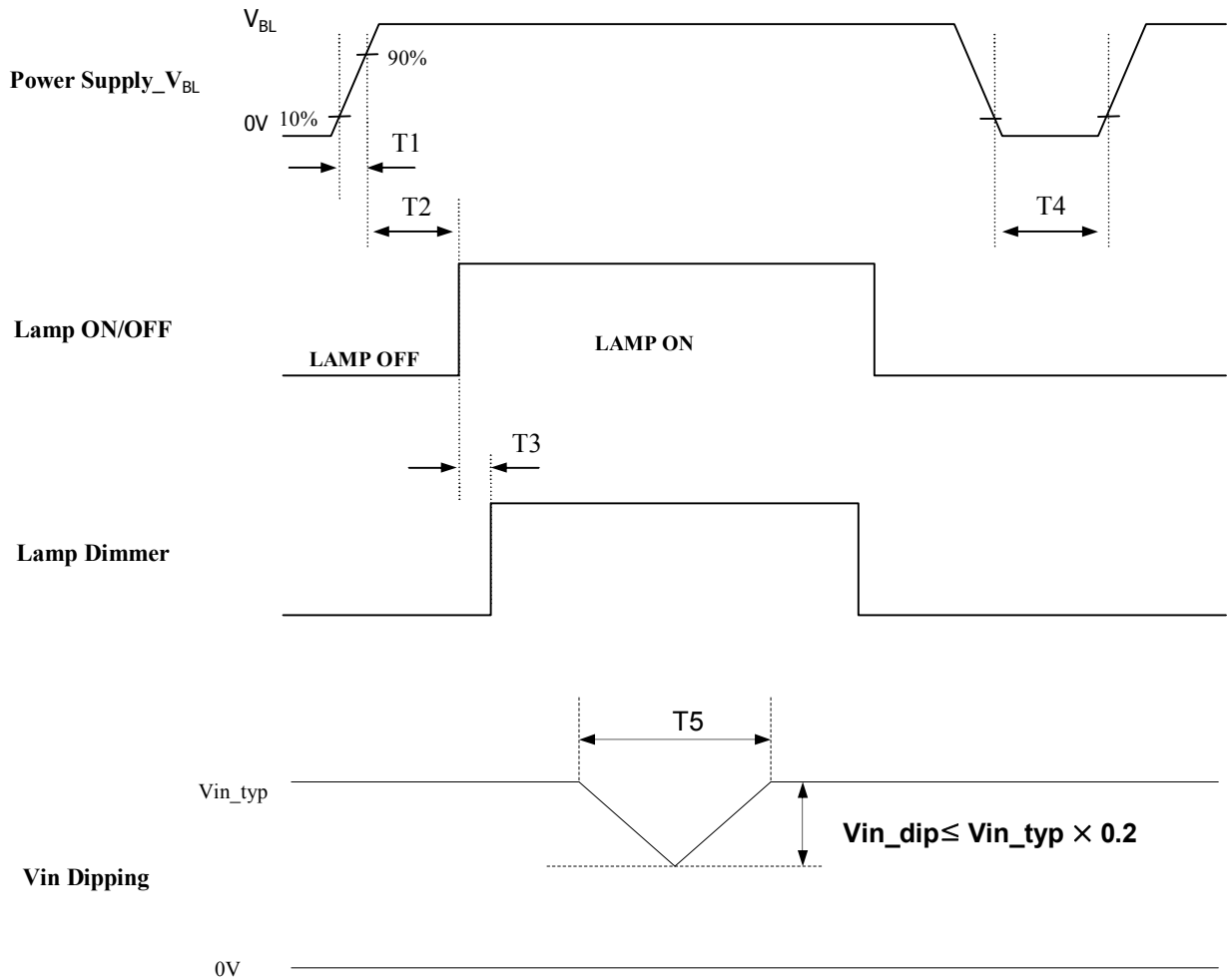

Table 11. Power Sequence

Parameter	Values			Units	Notes
	Min.	Typ.	Max.		
T1	1	-	30	ms	
T2	200	-	-	ms	
T3	-	-	50	ms	
T4	500	-	-	ms	
T5	-	-	10	ms	

4. Optical Specification

Optical characteristics are determined after the unit has been 'ON' and stable for approximately 30 minutes in a dark environment at 25 °C. The values specified are measured at an approximate distance 50cm from the LCD surface at a viewing angle of Φ and θ equal to 0 °.

Figure. 5 presents additional information concerning the measurement equipment and method.

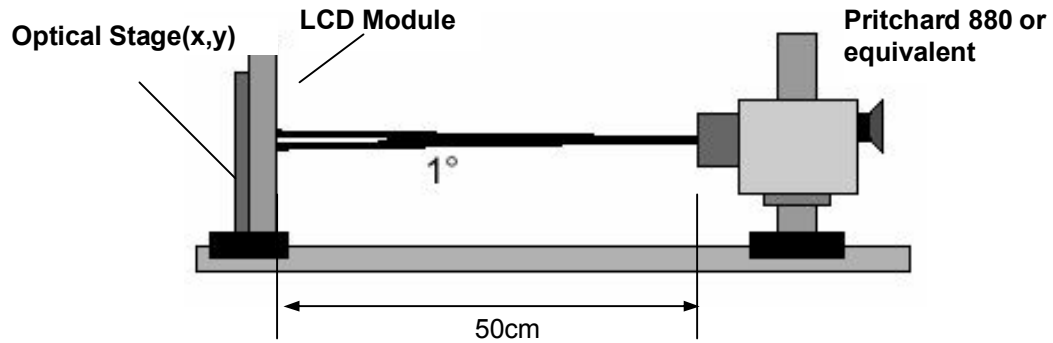

[Figure 5] Optical characteristic measurement equipment and method

Table 12. Optical characteristics (Ta=25±2°C, V_{LCD}=18V, f_V=60Hz, CLK=134.25MHz, I_{OUT}=5.5mA)

Parameter	Symbol	Values			Units	Notes	
		Min	Typ	Max			
Contrast Ratio	CR	(700)	1000			1	
Surface Luminance, white	L _{WH}	(300)	(370)		cd/m ²	2	
Luminance Variation	δ_{WHITE}	70	75	-	%	3	
Luminance Uniformity (angular dependant)		-	-	1.7	TCO '99		
Response Time	Rise Time	T _R	-	6	12	ms	4
	Decay Time	T _D	-	6	12	ms	4
	Gray To Gray	T _{GTG_AVR}	-	5	-	ms	5
		T _{GTG_MAX}	-	17	-	ms	5
Color Coordinates [CIE1931]	RED	R _x		(0.678)			
		R _y		(0.309)			
	GREEN	G _x		(0.210)			
		G _y	Typ -0.03	(0.692)	Typ +0.03		
	BLUE	B _x		(0.146)			
		B _y		(0.055)			
	WHITE	W _x		(0.313)			
	W _y		(0.329)				
Color shift	Horizontal	θ_{CST_H}	-	176	-	degree	6
	Vertical	θ_{CST_V}	-	176	-		
Viewing Angle (CR>10)							
general	Horizontal	θ_H	170	178	-	degree	7
	Vertical	θ_V	170	178	-		
Effective	Horizontal	θ_{GMA_H}	-	176	-	degree	8
	Vertical	θ_{GMA_V}	-	176	-		
Gray Scale			2.0	2.2	2.4		9

Product Specification

Notes 1. Contrast Ratio(CR) is defined mathematically as :

$$\text{Contrast Ratio} = \frac{\text{Surface Luminance with all white pixels}}{\text{Surface Luminance with all black pixels}}$$

2. Surface luminance is luminance value at No.1 point across the LCD surface 50cm from the surface with all pixels displaying white. For more information see FIG 6.

3. The variation in surface luminance , δ WHITE is defined as :

$$\delta_{\text{WHITE}} = \frac{\text{Minimum}(L_{\text{on1}}, L_{\text{on2}}, \dots, L_{\text{on9}})}{\text{Maximum}(L_{\text{on1}}, L_{\text{on2}}, \dots, L_{\text{on9}})} \times 100(\%)$$

Measuring point for surface luminance & measuring point for luminance variation

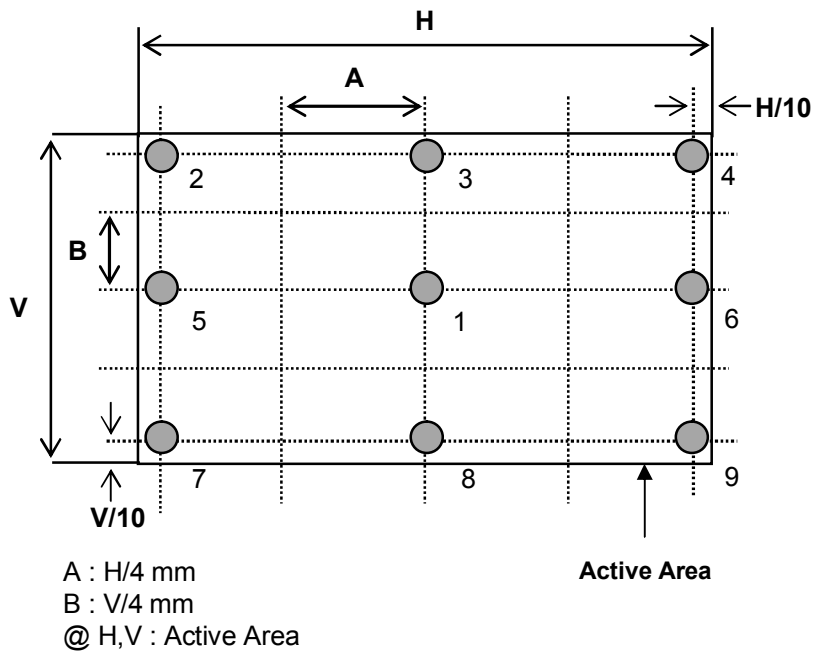

[Figure 6] Measure Point for Luminance

Product Specification

4. **The response time** is defined as the following figure and shall be measured by switching the input signal for “black” and “white”.
Response time is the time required for the display to transition from black to white (Rise Time, TrR) and from white to black (Decay Time, TrD).

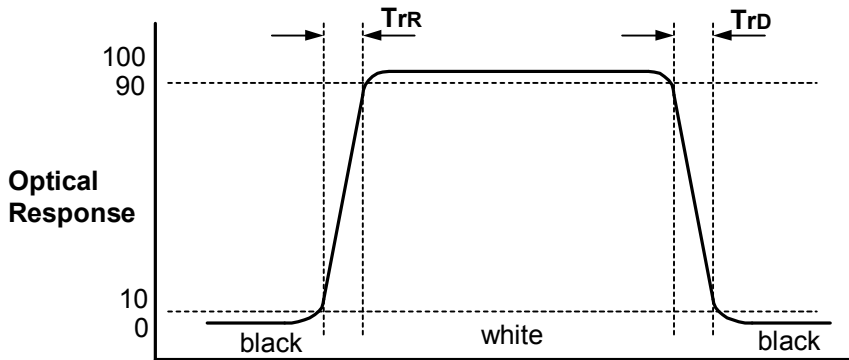

[Figure 7] Response Time

5. **The Gray to Gray response time** is defined as the following figure and shall be measured by switching the input signal for “Gray To Gray “.

- Gray step : 5 Step
- T_{GTG_AVR} is the total average time at rising time and falling time for “Gray To Gray “.
- T_{GTG_MAX} is the max time at rising time or falling time for “Gray To Gray “.

Gray to Gray		Rising Time				
		G255	G191	G127	G63	G0
Falling Time	G255					
	G191					
	G127					
	G63					
	G0					

Product Specification

6. **Color shift** is the angle at which the color difference is lower than 0.04.

- Color difference($\Delta u'v'$)

$$u' = \frac{4x}{-2x + 12y + 3}$$

$$v' = \frac{9y}{-2x + 12y + 3}$$

$$\Delta u'v' = \sqrt{(u'_1 - u'_2)^2 + (v'_1 - v'_2)^2}$$

u'_1, v'_1 : $u'v'$ value at viewing angle direction

u'_2, v'_2 : $u'v'$ value at front($\theta=0$)

- Pattern size : 25% Box size

- Viewing angle direction of color shift : Horizontal, Vertical

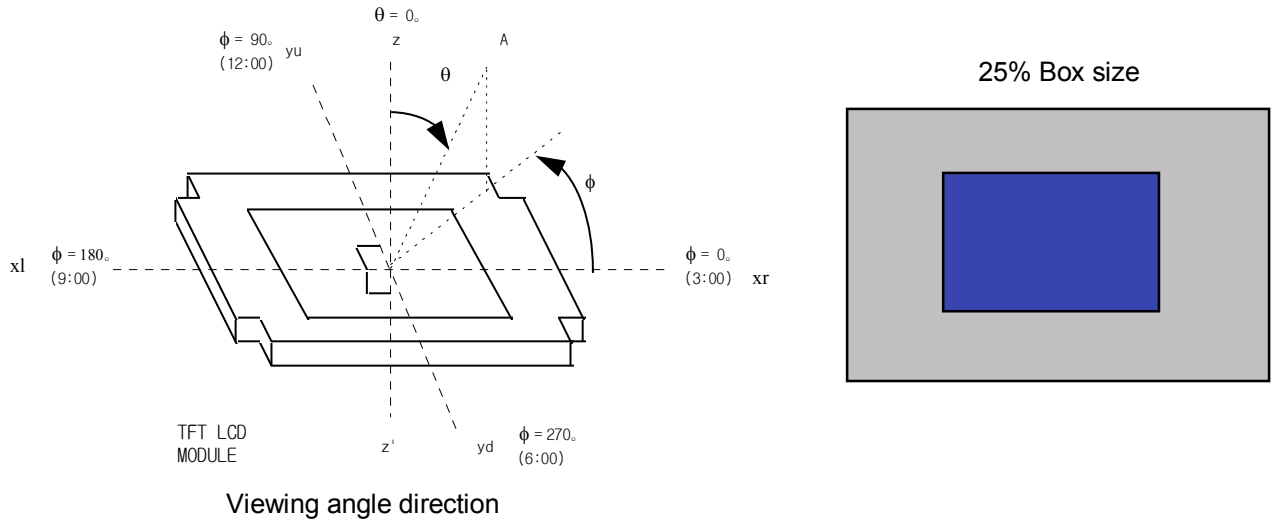

Viewing angle direction

Average RGB values in Bruce RGB for Macbeth Chart

	Dark skin	Light skin	Blue sky	Foliage	Blue flower	Bluish green
R	98	206	85	77	129	114
G	56	142	112	102	118	199
B	45	123	161	46	185	178
	Orange	Purplish blue	Moderate red	Purple	Yellow green	Orange yellow
R	219	56	211	76	160	230
G	104	69	67	39	193	162
B	24	174	87	86	58	29
	Blue	Green	Red	Yellow	Magenta	cyan
R	26	72	197	241	207	35
G	32	148	27	212	62	126
B	145	65	37	36	151	172
	White	Neutral 8	Neutral 6.5	Neutral 5	Neutral 3.5	black
R	240	206	155	110	63	22
G	240	206	155	110	63	22
B	240	206	155	110	63	22

Product Specification

7. **Viewing angle(general)** is the angle at which the contrast ratio is greater than 10.

8. **Effective viewing angle** is the angle at which the gamma shift of gray scale is lower than 0.3.

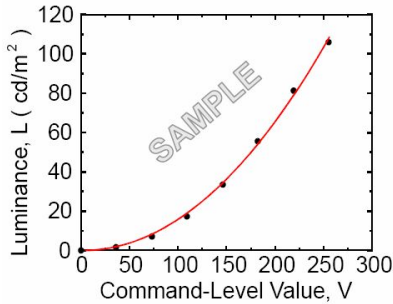

Fig. 1. Sample Luminance vs. gray scale (using a 256 bit gray scale).

$$L = aV^r + L_b$$

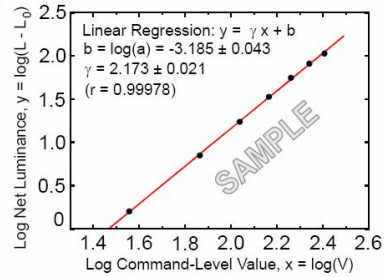

Fig. 2. Sample Log-log plot of luminance vs. gray scale.

$$\log(L - L_b) = r \log(V) + \log(a)$$

Here the Parameter α and γ relate the signal level V to the luminance L .

The GAMMA we calculate from the log-log representation

9. Gray scale specification

Gamma Value is approximately 2.2. For more information see Table 13.

Table 13. Gray Scale Specification

Gray Level	Relative Luminance [%] (Typ.)
0	0.3
31	1.2
63	4.68
95	11.7
127	21.2
159	35.2
191	53.0
223	75.4
255	100

10. TCO '99 item regarding Display characteristic is satisfied.

5. Mechanical Characteristics

The contents provide general mechanical characteristics. In addition the figures in the next page are detailed mechanical drawing of the LCD.

Table 14. Mechanical characteristics

Outline Dimension	Horizontal	677.30 mm
	Vertical	436.80 mm
	Depth	42.30 mm
Bezel Area	Horizontal	646.30 mm
	Vertical	405.80 mm
Active Display Area	Horizontal	641.28 mm
	Vertical	400.8 mm
Weight	5100g (Typ.), 5400g (Max.)	
Surface Treatment	Hard coating(3H) Anti-glare(13%) treatment of the front polarizer	

Notes : Please refer to a mechanic drawing in terms of tolerance at the next page.

Product Specification

<FRONT VIEW>

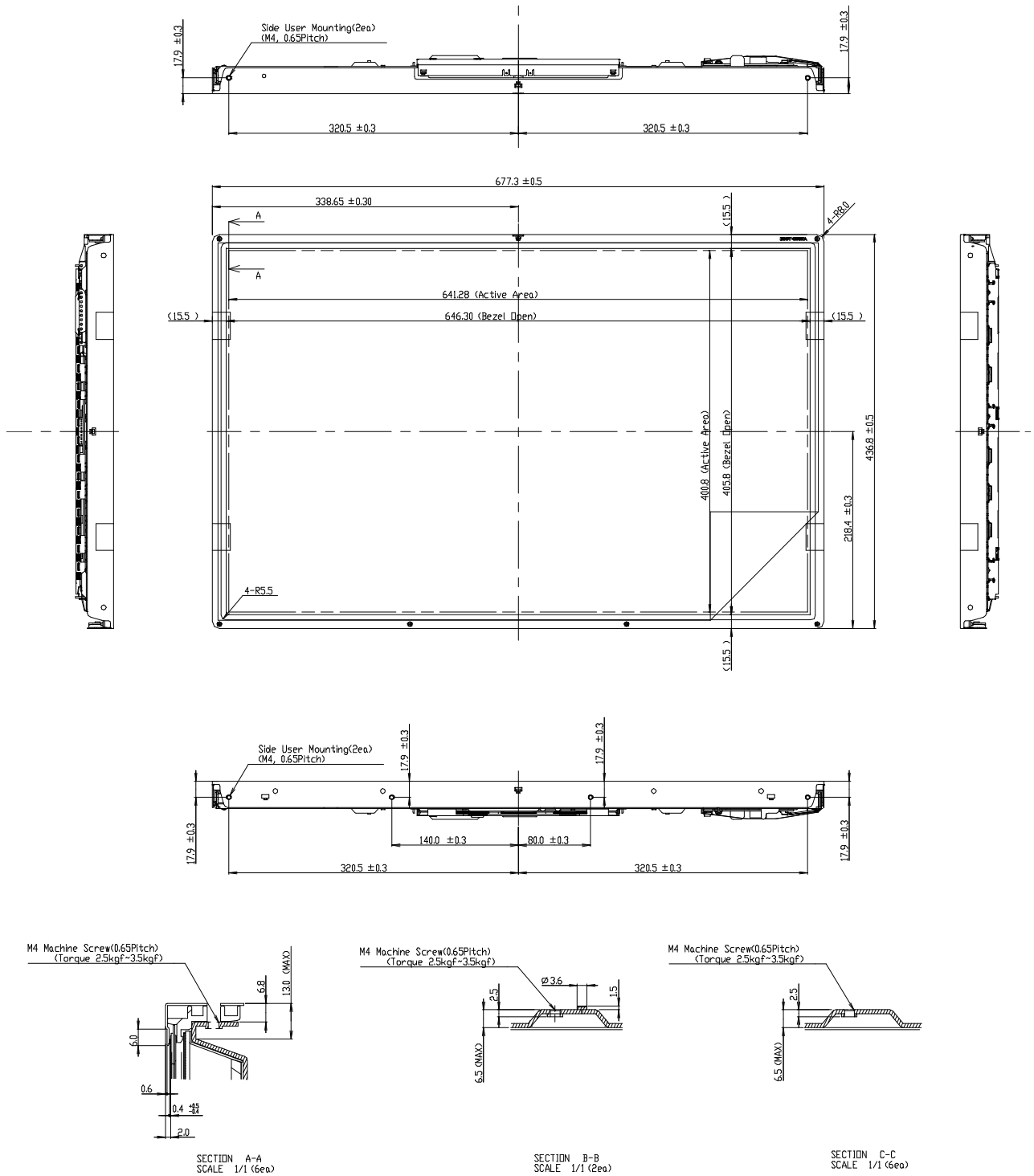

Product Specification

<REAR VIEW>

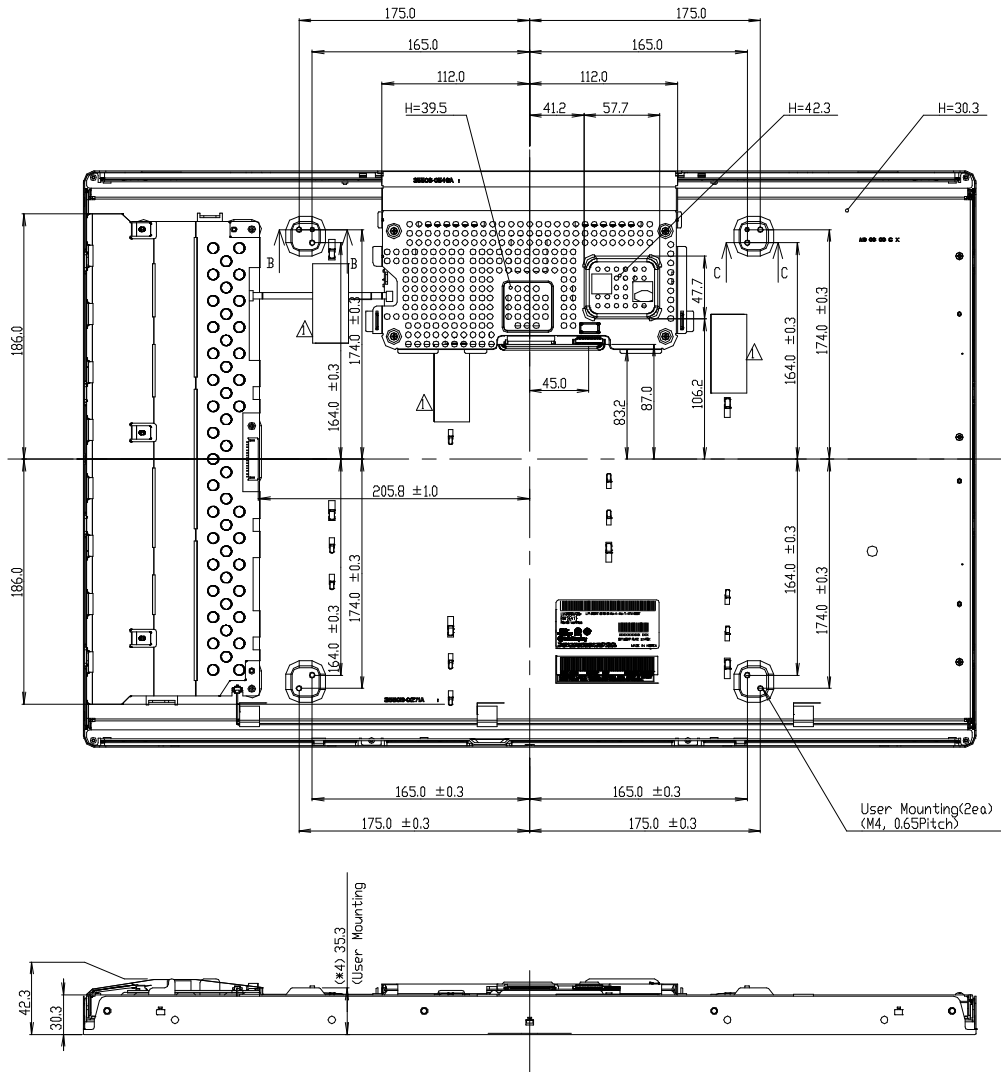

- Notes
1. Unspecified tolerances are to be ±0.5mm.
 2. Both backlight wires and contraction tubes are excluded from outline dimensions.
 3. Tilt and partial disposition tolerance of display area are as following.
 - (1) Y-direction : |A-B| < 1.4mm
 - (2) X-direction : |A-B| < 1.4mm
 4. User Connector Specification : KDF71G-30S-1H
 5. Power Connector Specification : DF19G-20P-1H

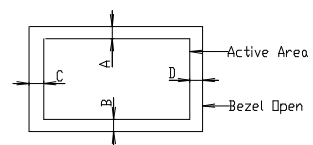

Product Specification

6. Reliability

Environment test condition

No	Test Item	Condition
1	High temperature storage test	Ta= 60°C 240h
2	Low temperature storage test	Ta= -20°C 240h
3	High temperature operation test	Ta= 50°C 50%RH 240h
4	Low temperature operation test	Ta= 0°C 240h
5	Vibration test (non-operating)	Wave form : random Vibration level : 1.0G RMS Bandwidth : 10-300Hz Duration : X,Y,Z, 30 min One time each direction
6	Shock test (non-operating)	Shock level : 120G Waveform : half sine wave, 2ms Direction : ±X, ±Y, ±Z One time each direction
7	Altitude operating storage / shipment	0 - 10,000 feet(3048m) 0 - 40,000 feet(12,192m)

7. International Standards

7-1. Safety

- a) UL 60950-1:2003, First Edition, Underwriters Laboratories, Inc., Standard for Safety of Information Technology Equipment.
- b) CAN/CSA C22.2, No. 60950-1-03 1st Ed. April 1, 2003, Canadian Standards Association, Standard for Safety of Information Technology Equipment.
- c) EN 60950-1:2001, First Edition, European Committee for Electrotechnical Standardization(CENELEC) European Standard for Safety of Information Technology Equipment.

7-2. EMC

- a) ANSI C63.4 "Methods of Measurement of Radio-Noise Emissions from Low-Voltage Electrical and Electrical Equipment in the Range of 9kHz to 40GHz. "American National Standards Institute(ANSI), 1992
- b) C.I.S.P.R. "Limits and Methods of Measurement of Radio Interface Characteristics of Information Technology Equipment." International Special Committee on Radio Interference.
- c) EN 55022 "Limits and Methods of Measurement of Radio Interface Characteristics of Information Technology Equipment." European Committee for Electrotechnical Standardization.(CENELEC), 1998 (Including A1: 2000)

8. Packing

8-1. Designation of Lot Mark

a) Lot Mark

A	B	C	D	E	F	G	H	I	J	K	L	M
---	---	---	---	---	---	---	---	---	---	---	---	---

A,B,C : SIZE(INCH)
E : MONTH

D : YEAR
F ~ M : SERIAL NO.

Note

1. YEAR

Year	2001 2011	2002 2012	2003 2013	2004 2014	2005 2015	2006 2016	2007 2017	2008 2018	2009 2019	2010 2020
Mark	1	2	3	4	5	6	7	8	9	0

2. MONTH

Month	Jan	Feb	Mar	Apr	May	Jun	Jul	Aug	Sep	Oct	Nov	Dec
Mark	1	2	3	4	5	6	7	8	9	A	B	C

b) Location of Lot Mark

Serial No. is printed on the label. The label is attached to the backside of the LCD module.
This is subject to change without prior notice.

8-2. Packing Form

a) Package quantity in one box : 5 pcs

b) Box size : 756mm X 343mm X 515mm.

9. Precautions

Please pay attention to the following when you use this TFT LCD module.

9-1. Mounting Precautions

- (1) You must mount a module using holes (refer 26~27 page)
- (2) You should consider the mounting structure so that uneven force(ex. twisted stress) is not applied to the module.
And the case on which a module is mounted should have sufficient strength so that external force is not transmitted directly to the module.
- (3) Please attach a transparent protective plate to the surface in order to protect the polarizer.
Transparent protective plate should have sufficient strength in order to resist external force.
- (4) You should adopt radiation structure to satisfy the temperature specification.
- (5) Acetic acid type and chlorine type materials for the cover case are not describe because the former generates corrosive gas of attacking the polarizer at high temperature and the latter causes circuit break by electro-chemical reaction.
- (6) Do not touch, push or rub the exposed polarizers with glass, tweezers or anything harder than HB pencil lead. And please do not rub with dust clothes with chemical treatment.
Do not touch the surface of polarizer for bare hand or greasy cloth.(Some cosmetics are determined to the polarizer.)
- (7) When the surface becomes dusty, please wipe gently with absorbent cotton or other soft materials like chamois soaks with petroleum benzene. Normal-hexane is recommended for cleaning the adhesives used to attach front / rear polarizers. Do not use acetone, toluene and alcohol because they cause chemical damage to the polarizer.
- (8) Wipe off saliva or water drops as soon as possible. Their long time contact with polarizer causes deformations and color fading.
- (9) Do not open the case because inside circuits do not have sufficient strength.

9-2. Operating Precautions

- (1) The spike noise causes the mis-operation of circuits. It should be lower than following voltage :
 $V = \pm 200\text{mV}$ (Over and under shoot voltage)
- (2) Response time depends on the temperature.(In lower temperature, it becomes longer.)
- (3) Brightness depends on the temperature. (In lower temperature, it becomes lower.)
And in lower temperature, response time(required time that brightness is stable after turned on) becomes longer.
- (4) Be careful for condensation at sudden temperature change. Condensation makes damage to polarizer or electrical contacted parts. And after fading condensation, smear or spot will occur.
- (5) When fixed patterns are displayed for a long time, remnant image is likely to occur.
- (6) Module has high frequency circuits. Sufficient suppression to the electromagnetic interference shall be done by system manufacturers. Grounding and shielding methods may be important to minimized the interference.
- (7) Please do not give any mechanical and/or acoustical impact to LCM. Otherwise, LCM can not be operated its full characteristics perfectly.
- (8) A screw which is fastened up the steels should be a machine screw (if not, it causes metal foreign material and deal LCM a fatal blow)
- (9) Please do not set LCD on its edge.

9-3. Electrostatic Discharge Control

Since a module is composed of electronic circuits, it is not strong to electrostatic discharge. Make certain that treatment persons are connected to ground through wrist band etc. And don't touch interface pin directly.

9-4. Precautions for Strong Light Exposure

Strong light exposure causes degradation of polarizer and color filter.

9-5. Storage

When storing modules as spares for a long time, the following precautions are necessary.

- (1) Store them in a dark place. Do not expose the module to sunlight or fluorescent light. Keep the temperature between 5°C and 35°C at normal humidity.
- (2) The polarizer surface should not come in contact with any other object.
It is recommended that they be stored in the container in which they were shipped.

9-6. Handling Precautions for Protection Film

- (1) The protection film is attached to the bezel with a small masking tape.
When the protection film is peeled off, static electricity is generated between the film and polarizer. This should be peeled off slowly and carefully by people who are electrically grounded and with well ion-blown equipment or in such a condition, etc.
- (2) When the module with protection film attached is stored for a long time, sometimes there remains a very small amount of glue still on the Bezel after the protection film is peeled off.
- (3) You can remove the glue easily. When the glue remains on the Bezel or its vestige is recognized, please wipe them off with absorbent cotton waste or other soft material like chamois soaked with normal-hexane.