

APT802R4CN	800V	4.5A	2.40Ω
APT752R4CN	750V	4.5A	2.40Ω
APT802R8CN	800V	4.0A	2.80Ω
APT752R8CN	750V	4.0A	2.80Ω

POWER MOS IV™

N-CHANNEL ENHANCEMENT MODE HIGH VOLTAGE POWER MOSFETS

MAXIMUM RATINGS

All Ratings: $T_C = 25^\circ\text{C}$ unless otherwise specified.

Symbol	Parameter	APT 752R4CN	APT 802R4CN	APT 752R8CN	APT 802R8CN	UNIT
V_{DSS}	Drain-Source Voltage	750	800	750	800	Volts
I_D	Continuous Drain Current @ $T_C = 25^\circ\text{C}$	4.5		4.0		Amps
I_{DM}	Pulsed Drain Current ①	18		16		
V_{GS}	Gate-Source Voltage	±30				Volts
P_D	Total Power Dissipation @ $T_C = 25^\circ\text{C}$	125				Watts
	Linear Derating Factor	1.0				W/°C
T_J, T_{STG}	Operating and Storage Junction Temperature Range	-55 to 150				°C
T_L	Lead Temperature: 0.063" from Case for 10 Sec.	300				

STATIC ELECTRICAL CHARACTERISTICS

Symbol	Characteristic / Test Conditions / Part Number	MIN	TYP	MAX	UNIT	
BV_{DSS}	Drain-Source Breakdown Voltage ($V_{GS} = 0V, I_D = 250 \mu\text{A}$)	APT802R4CN / APT802R8CN	800			Volts
		APT752R4CN / APT752R8CN	750			
$I_{D(ON)}$	On State Drain Current ② ($V_{DS} > I_{D(ON)} \times R_{DS(ON)}$ Max, $V_{GS} = 10V$)	APT802R4CN / APT752R4CN	4.5			Amps
		APT802R8CN / APT752R8CN	4.0			
$R_{DS(ON)}$	Drain-Source On-State Resistance ② ($V_{GS} = 10V, 0.5 I_D$ [Cont.])	APT802R4CN / APT752R4CN			2.40	Ohms
		APT802R8CN / APT752R8CN			2.80	
I_{DSS}	Zero Gate Voltage Drain Current ($V_{DS} = V_{DSS}, V_{GS} = 0V$)			250	μA	
	Zero Gate Voltage Drain Current ($V_{DS} = 0.8 V_{DSS}, V_{GS} = 0V, T_C = 125^\circ\text{C}$)			1000		
I_{GSS}	Gate-Source Leakage Current ($V_{GS} = \pm 30V, V_{DS} = 0V$)			±100	nA	
$V_{GS(TH)}$	Gate Threshold Voltage ($V_{DS} = V_{GS}, I_D = 1.0\text{mA}$)	2		4	Volts	

THERMAL CHARACTERISTICS

Symbol	Characteristic	MIN	TYP	MAX	UNIT
$R_{\theta JC}$	Junction to Case			1.00	°C/W
$R_{\theta JA}$	Junction to Ambient			50	

405 S.W. COLUMBIA STREET
BEND, OREGON 97702-1035
U.S.A.

PHONE . . . (503) 382-8028

FAX (503) 388-0364

DYNAMIC CHARACTERISTICS

APT802R4/752R4/802R8/752R8CN

Symbol	Characteristic	Test Conditions	MIN	TYP	MAX	UNIT
C_{DC}	Drain-to-Case Capacitance	$f = 1 \text{ MHz}$		15	22	pF
C_{iss}	Input Capacitance	$V_{GS} = 0V$		790	950	
C_{oss}	Output Capacitance	$V_{DS} = 25V$		116	163	
C_{rss}	Reverse Transfer Capacitance	$f = 1 \text{ MHz}$		44	66	
Q_g	Total Gate Charge ③	$V_{GS} = 10V$		38	55	nC
Q_{gs}	Gate-Source Charge	$V_{DD} = 0.5 V_{DSS}$		4.5	7	
Q_{gd}	Gate-Drain ("Miller") Charge	$I_D = I_D [\text{Cont.}] @ 25^\circ\text{C}$		16	24	
$t_d(\text{on})$	Turn-on Delay Time	$V_{GS} = 15V$		10	20	ns
t_r	Rise Time	$V_{DD} = 0.5 V_{DSS}$		11	22	
$t_d(\text{off})$	Turn-off Delay Time	$I_D = I_D [\text{Cont.}] @ 25^\circ\text{C}$		35	53	
t_f	Fall Time	$R_G = 1.8\Omega$		13	26	

SOURCE-DRAIN DIODE RATINGS AND CHARACTERISTICS

Symbol	Characteristic / Test Conditions	MIN	TYP	MAX	UNIT
I_S	Continuous Source Current (Body Diode)	APT802R4CN / APT752R4CN		4.5	Amps
		APT802R8CN / APT752R8CN		4.0	
I_{SM}	Pulsed Source Current ① (Body Diode)	APT802R4CN / APT752R4CN		18	Amps
		APT802R8CN / APT752R8CN		16	
V_{SD}	Diode Forward Voltage ② ($V_{GS} = 0V, I_S = -I_D [\text{Cont.}]$)			1.3	Volts
t_{rr}	Reverse Recovery Time ($I_S = -I_D [\text{Cont.}], di_S/dt = 100A/\mu s$)	160	320	640	ns
Q_{rr}	Reverse Recovery Charge ($I_S = -I_D [\text{Cont.}], di_S/dt = 100A/\mu s$)	1.5	3.0	6.0	μC

SAFE OPERATING AREA CHARACTERISTICS

Symbol	Characteristic	Test Conditions	MIN	TYP	MAX	UNIT
SOA1	Safe Operating Area	$V_{DS} = 0.4 V_{DSS}, I_{DS} = P_D / 0.4 V_{DSS}, t = 1 \text{ Sec.}$	125			Watts
SOA2	Safe Operating Area	$I_{DS} = I_D [\text{Cont.}], V_{DS} = P_D / I_D [\text{Cont.}], t = 1 \text{ Sec.}$	125			
I_{LM}	Inductive Current Clamped	APT802R4CN / APT752R4CN	18			Amps
		APT802R8CN / APT752R8CN	16			

- ① Repetitive Rating: Pulse width limited by maximum junction temperature. See Transient Thermal Impedance Curve. (Fig. 1)
- ② Pulse Test: Pulse width < 380 μs , Duty Cycle < 2%
- ③ See MIL-STD-750 Method 3471

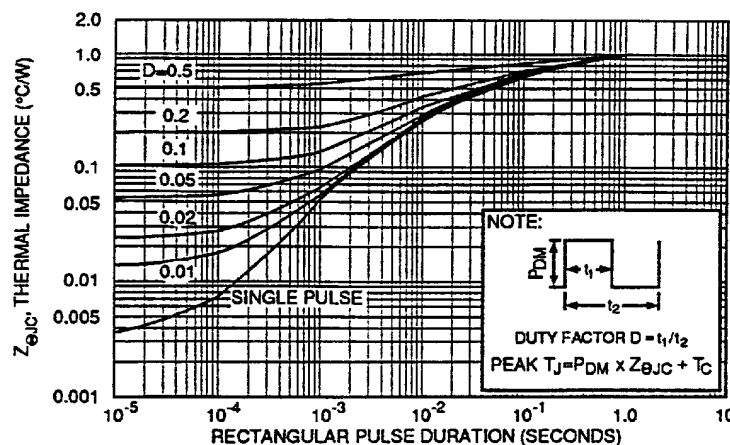

FIGURE 1, MAXIMUM EFFECTIVE TRANSIENT THERMAL IMPEDANCE, JUNCTION-TO-CASE vs PULSE DURATION

APT802R4/752R4/802R8/752R8CN

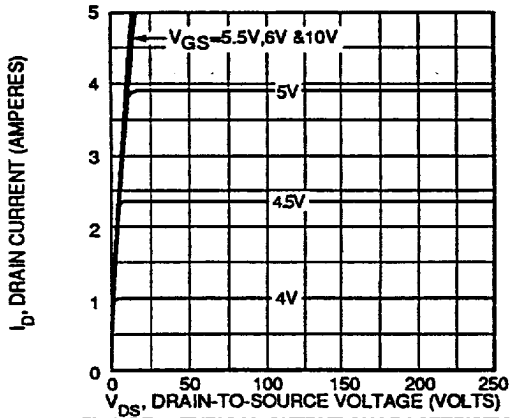

FIGURE 2, TYPICAL OUTPUT CHARACTERISTICS

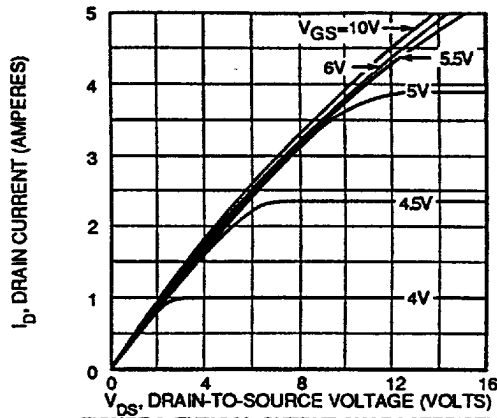

FIGURE 3, TYPICAL OUTPUT CHARACTERISTICS

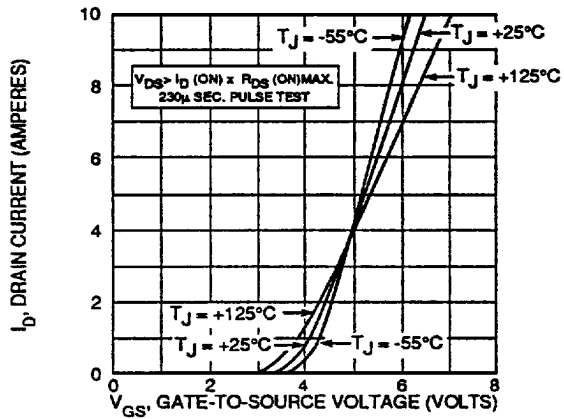

FIGURE 4, TYPICAL TRANSFER CHARACTERISTICS

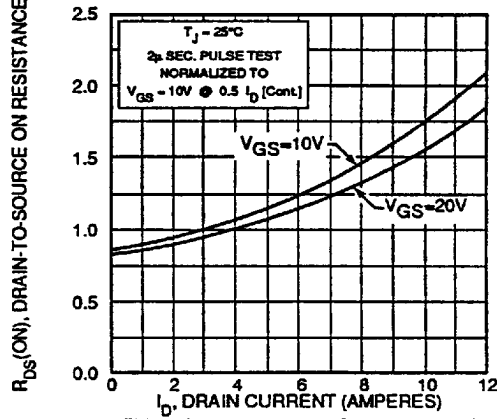

FIGURE 5, $R_{DS(ON)}$ vs DRAIN CURRENT

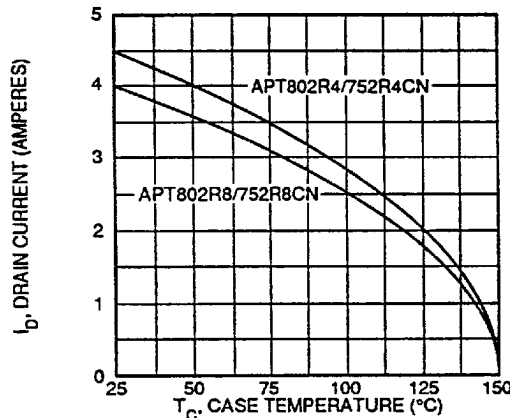

FIGURE 6, MAXIMUM DRAIN CURRENT vs CASE TEMPERATURE

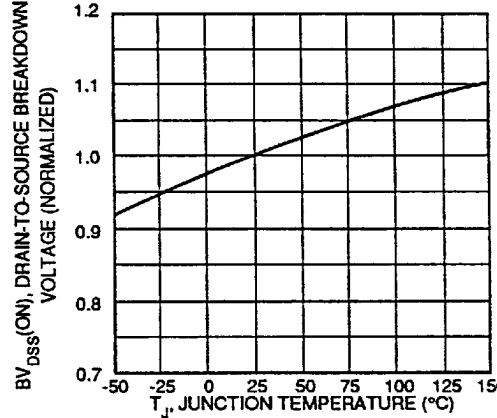

FIGURE 7, BREAKDOWN VOLTAGE vs TEMPERATURE

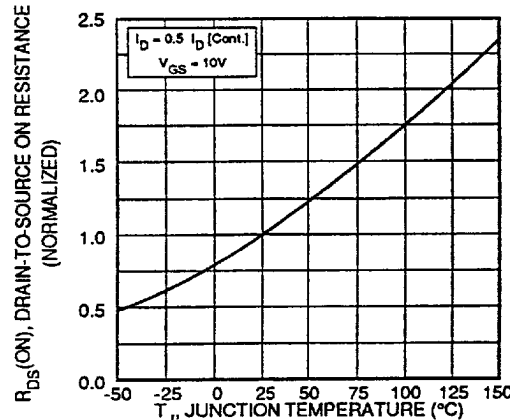

FIGURE 8, ON-RESISTANCE vs. TEMPERATURE

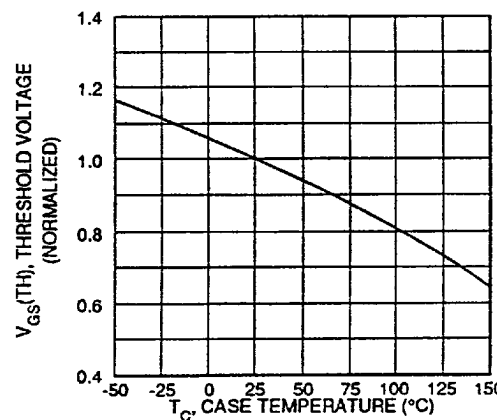

FIGURE 9, THRESHOLD VOLTAGE vs TEMPERATURE

3

APT802R4/752R4/802R8/752R8CN

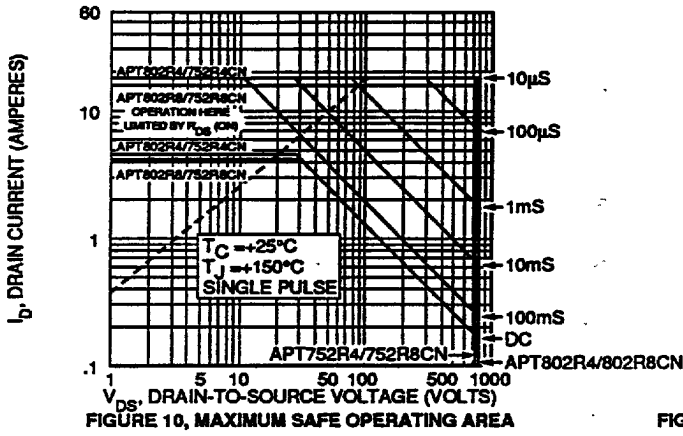

FIGURE 10, MAXIMUM SAFE OPERATING AREA

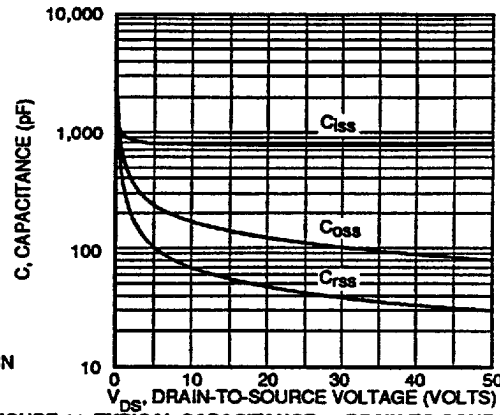

FIGURE 11, TYPICAL CAPACITANCE vs DRAIN-TO-SOURCE VOLTAGE

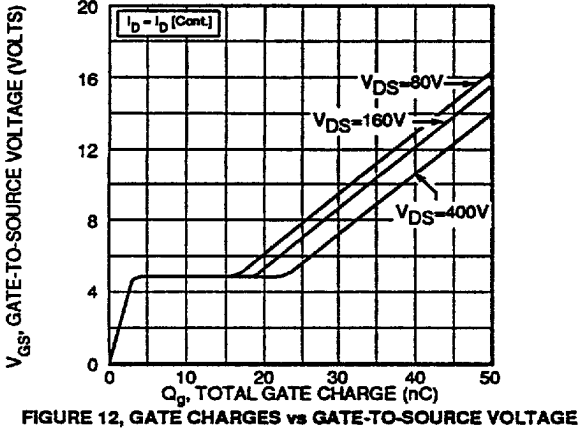

FIGURE 12, GATE CHARGES vs GATE-TO-SOURCE VOLTAGE

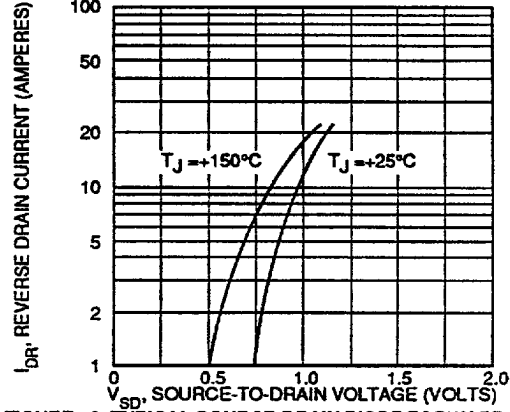
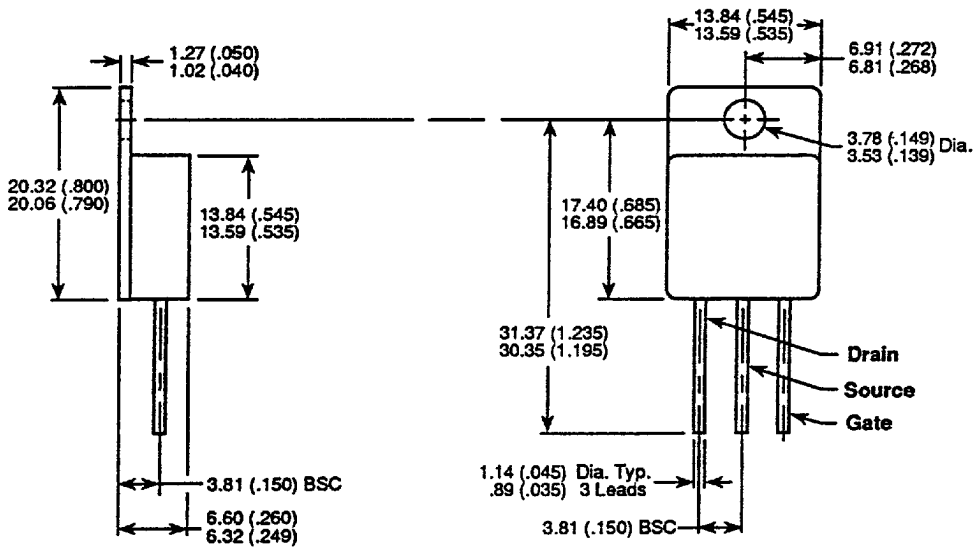

FIGURE 13, TYPICAL SOURCE-DRAIN DIODE FORWARD VOLTAGE

TO-254AA Package Outline



Dimensions in Millimeters and (Inches)

050-8017 Rev A