

PLEASE CHECK WWW.MOLEX.COM FOR LATEST PART INFORMATION

Part Number: [0190710144](#)
Status: **Active**
Description: InsulKrimp™ Ring Tongue Terminal for 8 AWG Wire

Documents:

[Drawing \(PDF\)](#) [RoHS Certificate of Compliance \(PDF\)](#)
[Product Specification PS-19902-009 \(PDF\)](#)

General

Product Family	Ring and Spade Terminals
Series	19071
Crimp Quality Equipment	Yes
Mil-Spec	N/A
Product Name	InsulKrimp™
Type	Ring

Physical

Barrel Type	Closed
Color - Resin	Natural
Insulation	PVC
Material - Plating Mating	Tin
Packaging Type	Bag
Stud Size	5/16" (M8)
Termination Interface: Style	Crimp or Compression
Wire Insulation Diameter	6.70mm (.265") max.
Wire Size AWG	8
Wire Size mm²	0.60 - 10.5

Material Info

Old Part Number	D-650-56X
-----------------	-----------

Reference - Drawing Numbers

Product Specification	PS-19902-009
Sales Drawing	SD-19071-002

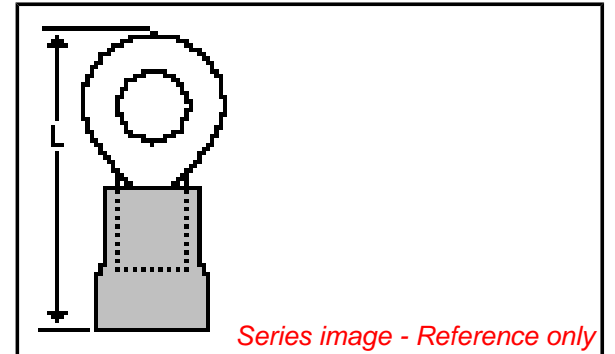

EU RoHS

**ELV and RoHS
Compliant**
REACH SVHC
 Not Reviewed
**Halogen-Free
Status**

China RoHS



**Need more information on product
environmental compliance?**

Email productcompliance@molex.com
 For a multiple part number RoHS Certificate of Compliance, [click here](#)

Please visit the [Contact Us](#) section for any non-product compliance questions.

Search Parts in this Series

[19071Series](#)

Application Tooling | [FAQ](#)

Tooling specifications and manuals are found by selecting the products below. Crimp Height Specifications are then contained in the Application Tooling Specification document.

Global

Description	Product #
Manual Putt Pump Hydraulic System, Die set required	0192860117
Die Set (large) for the HHLS Hydraulic Crimper	0192890001
Hand Crimp Tool	0640013900
Putt Pump Dieless Head System	0192860065

MATERIAL: Copper
 PLATING: Electro-Tin (.0003 Min.)
 INSULATION: PVC Color Coded Red
 STUD SIZES: ("D" ±.005)

INSULKRIMP X

06 - .146"	38 - .390"
08 - .173"	76 - .453"
10 - .198"	12 - .515"
14 - .265"	58 - .656"
56 - .328"	34 - .781"

ASSEMBLY IS ROHS COMPLIANT.

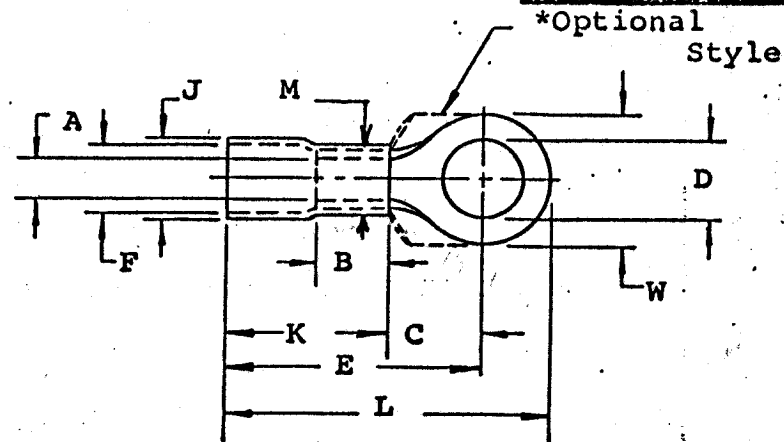

"M" - .375" Maximum

Part Number	"W"	"C" Min.	"E" Max.	"K" Max.	"L" Max.	"A" Min. Avg.	"F" (MWID)	THICKNESS REF	"J" Max.	"B" Min.	Available Stud Size
D-650-X	.478 .458	.363	1.088	.675	1.306	.165	.385	.045	.475	.315	06, 08, 10, 14, 56
D-651-X	.593 .573	.428	1.148	.675	1.427	.165	.385	.045	.475	.315	10, 14, 56, 38, 76
D-652-X	.822 .798	.611	1.336	.675	1.728	.165	.385	.050	.475	.315	10, 14, 56, 38, 76, 12, 58
D-653-X	1.137 1.113	.986	1.715	.675	2.278	.165	.385	.050	.475	.315	14, 56, 38, 76, 12 58, 34
D-656-X	.384 .364	.363	1.088	.675	1.265	.165	.385	.045	.475	.315	06, 08, 10, 14

NOTE: (MWID) denotes maximum wire insulation diameter.



TITLE: CUSTOMER DRAWING
 #8 WIRE RANGE (D)
 RING TONGUE TERMINAL

DIMENSIONAL TOLERANCE UNLESS OTHERWISE SPECIFIED		
FRAC.	DEC.	ANG.
±	±	±

REVISION	
A	8 MIN WAS 300 FP 7-20-89
B	ETC2007-0019

SCALE: _____	DATE
DRWN. BY: JTK	1-21-70
CHKD. BY:	
APPRD. BY:	
DRAWING NO.:	