

SKT 12,4 Qu RG bond.

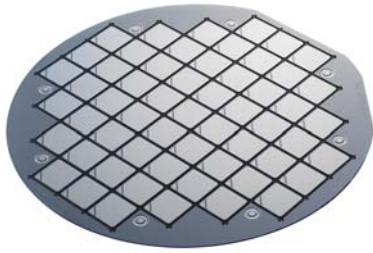

THYRISTOR

$$I_{T(DC)} = 165 \text{ A}$$

$$V_{RRM} = 1600 \text{ V}$$

Size: 12,4 mm x 12,4 mm

Corner gate

SKT 12,4 Qu RG bond.

Features

- high current density due to double mesa technology
- high surge current
- compatible to thick wire bonding
- compatible to all standard solder processes

Typical Applications*

- controlled rectifier circuits
- solid state relays



SKT

Absolute Maximum Ratings			
Symbol	Conditions	Values	Unit
V_{RRM}	$T_j = 25 \text{ }^\circ\text{C}$, $I_R = 0.45 \text{ mA}$	1600	V
V_{DRM}	$T_j = 25 \text{ }^\circ\text{C}$, $I_D = 0.45 \text{ mA}$	1600	V
$I_{T(AV)}$	$T_c = 80 \text{ }^\circ\text{C}$, $T_j = 130 \text{ }^\circ\text{C}$	130	A
I_{TSM}	$T_j = 130 \text{ }^\circ\text{C}$, 10 ms, sin 180°	1800	A
i^2t	$T_j = 130 \text{ }^\circ\text{C}$, 10 ms, sin 180°	16200	A ² s
T_{jmax}		130	°C

Electrical Characteristics					
Symbol	Conditions	min.	typ.	max.	Unit
V_T	$T_j = 130 \text{ }^\circ\text{C}$, $I_T = 165 \text{ A}$			1.2	V
$V_{T(TO)}$	$T_j = 130 \text{ }^\circ\text{C}$			0.85	V
r_T	$T_j = 130 \text{ }^\circ\text{C}$			2.2	mΩ
I_{GT}	$T_j = 25 \text{ }^\circ\text{C}$			100	mA
V_{GT}	$T_j = 25 \text{ }^\circ\text{C}$			1.98	V
I_{GD}	$T_j = 115 \text{ }^\circ\text{C}$	6			mA
V_{GD}	$T_j = 130 \text{ }^\circ\text{C}$	0.25			V
I_H	$T_j = 25 \text{ }^\circ\text{C}$			220	mA
I_L	$T_j = 25 \text{ }^\circ\text{C}$			550	mA

Dynamic Characteristics					
Symbol	Conditions	min.	typ.	max.	Unit
t_q	$T_j = 130 \text{ }^\circ\text{C}$		150		μs
$(di/dt)_{cr}$	$T_j = 130 \text{ }^\circ\text{C}$			100	A/μs
$(dv/dt)_{cr}$	$T_j = 130 \text{ }^\circ\text{C}$			1000	V/μs

Thermal Characteristics					
Symbol	Conditions	min.	typ.	max.	Unit
T_j		-40		130	°C
T_{stg}		-40		130	°C
T_{solder}				255	°C
$R_{th(j-c)}$	Semipack 1 assembly		0.25		K/W

Mechanical Characteristics			
Symbol	Conditions	Values	Unit
Raster size		12.4 x 12.4	mm ²
Area total		153.8	mm ²
Anode		solderable (Ag/Ni)	
Gate and Cathode		bondable (Al)	
Wire bond		Al, diameter ≤ 500μm	
Package		tray	
Chips / Package		36	pcs

SKT 12,4 Qu RG bond.

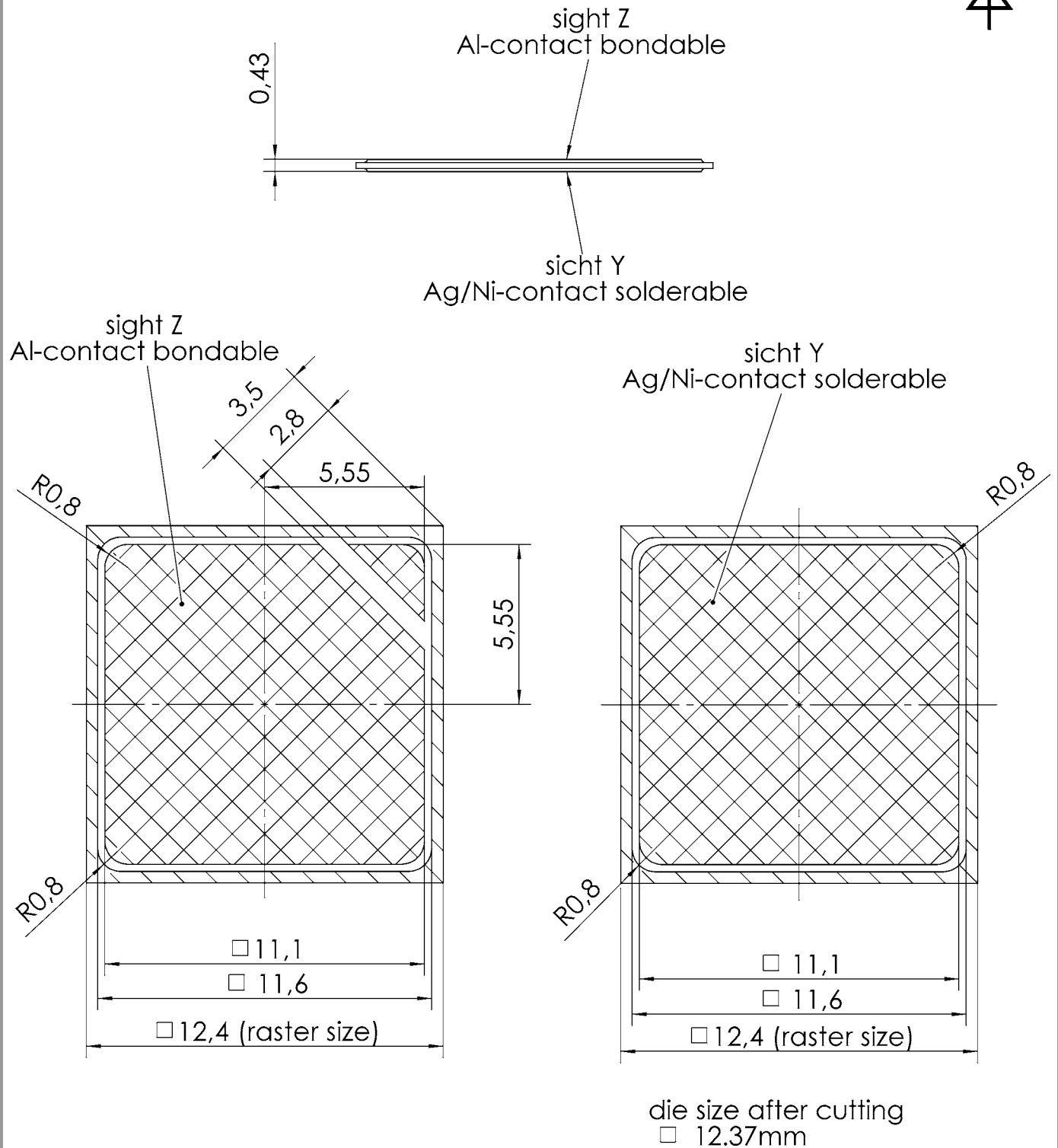

This is an electrostatic discharge sensitive device (ESDS), international standard IEC 60747-1, Chapter IX

* The specifications of our components may not be considered as an assurance of component characteristics. Components have to be tested for the respective application. Adjustments may be necessary. The use of SEMIKRON products in life support appliances and systems is subject to prior specification and written approval by SEMIKRON. We therefore strongly recommend prior consultation of our personal.