

SHINDENGEN

Super Fast Recovery Rectifiers

Single

M1FL40

400V 1.5A

FEATURES

- Small SMT
- Low noise
- trr50ns

APPLICATION

- Switching power supply
- DC/DC converter
- Fry Wheel
- Home Appliances, Office Equipment
- Telecommunication, Factory Automation

OUTLINE DIMENSIONS

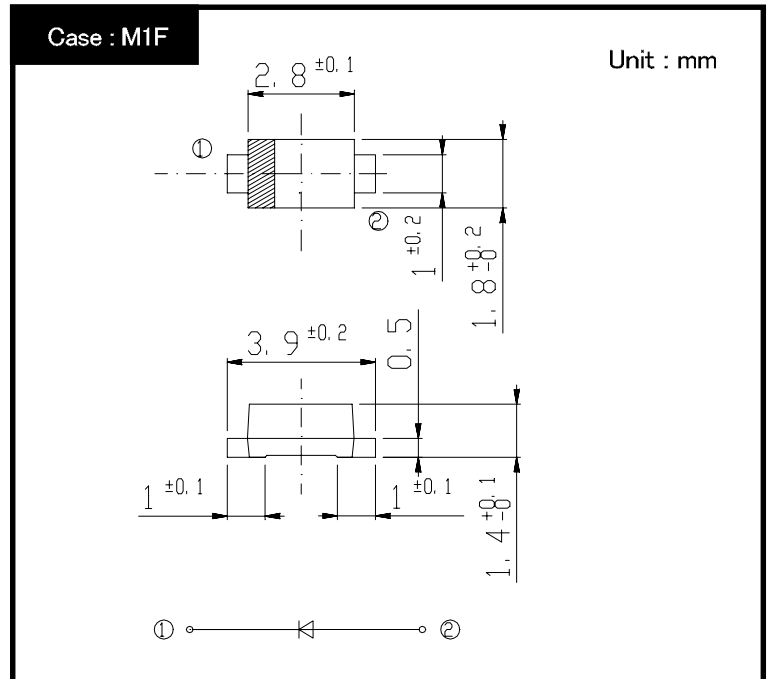

RATINGS

● Absolute Maximum Ratings (If not specified Tc=25°C)

Item	Symbol	Conditions	Ratings	Unit
Storage Temperature	Tstg		-55 ~ 150	°C
Operating Junction Temperature	Tj		150	°C
Maximum Reverse Voltage	V _{RM}		400	V
Average Rectified Forward Current	I _O	50Hz sine wave, R-load, Tc=104°C	1.5	A
		50Hz sine wave, R-load, Ta=25°C On glass-epoxy substrate	1.0	
Peak Surge Forward Current	I _{FSM}	50Hz sine wave, Non-repetitive 1 cycle peak value, Tj=25°C	25	A

● Electrical Characteristics (If not specified Tc=25°C)

Item	Symbol	Conditions	Ratings	Unit
Forward Voltage	V _F	I _F = 1A, Pulse measurement	Max 1.3	V
Reverse Current	I _R	V _R = V _{RM} , Pulse measurement	Max 10	μA
Reverse Recovery Time	trr	I _F = 0.5A, I _R = 1.0A	Max 50	ns
Junction Capacitance	C _j	f = 1MHz, V _R = 10V	TYP 9	pF
Thermal Resistance	θ _{jc}	junction to case	Max 18	°C/W
	θ _{jl}	junction to lead	Max 20	
	θ _{ja}	junction to ambient On glass-epoxy substrate	Max 80	

M1FL40 Forward Voltage

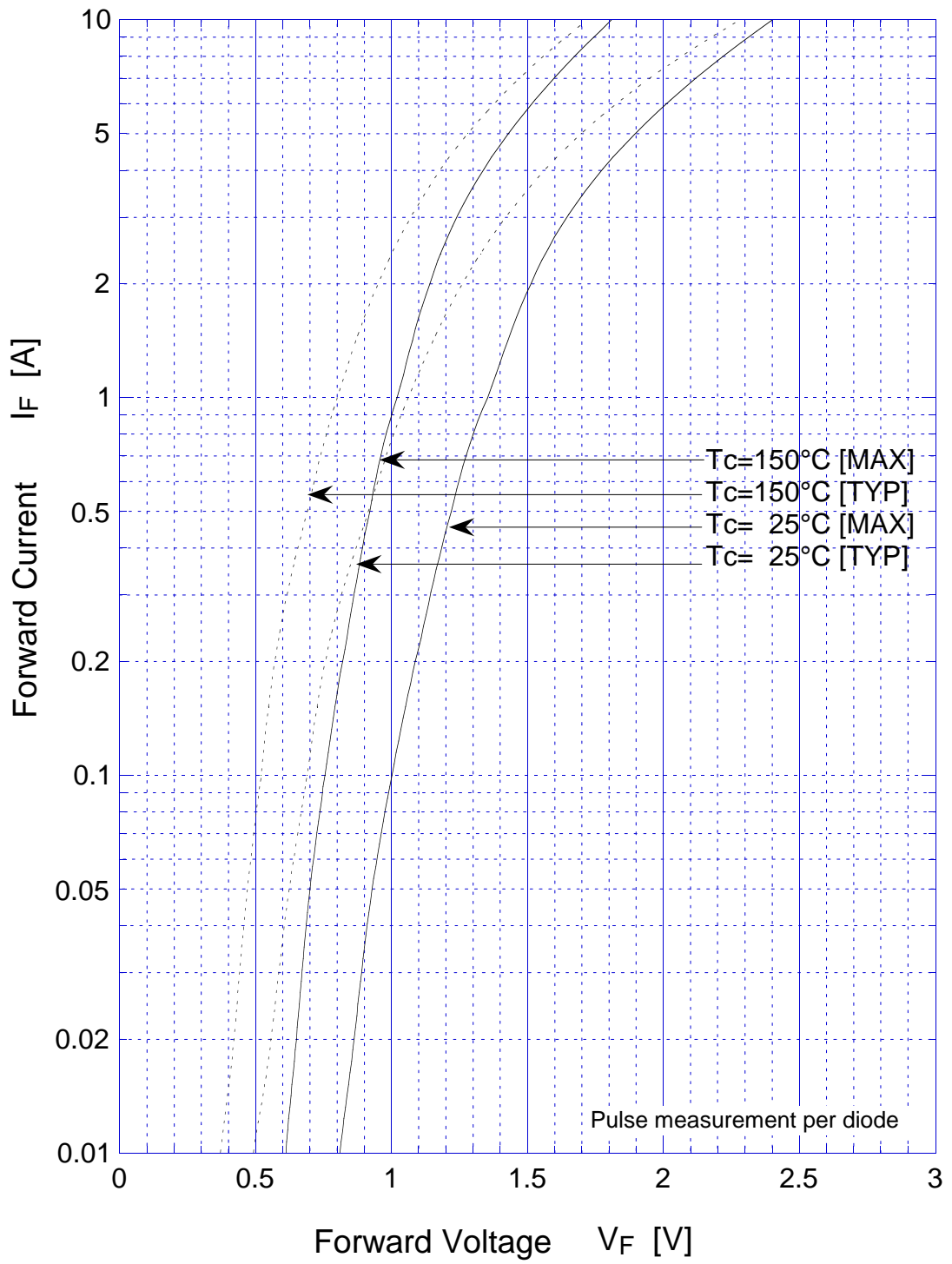

M1FL40 Forward Power Dissipation

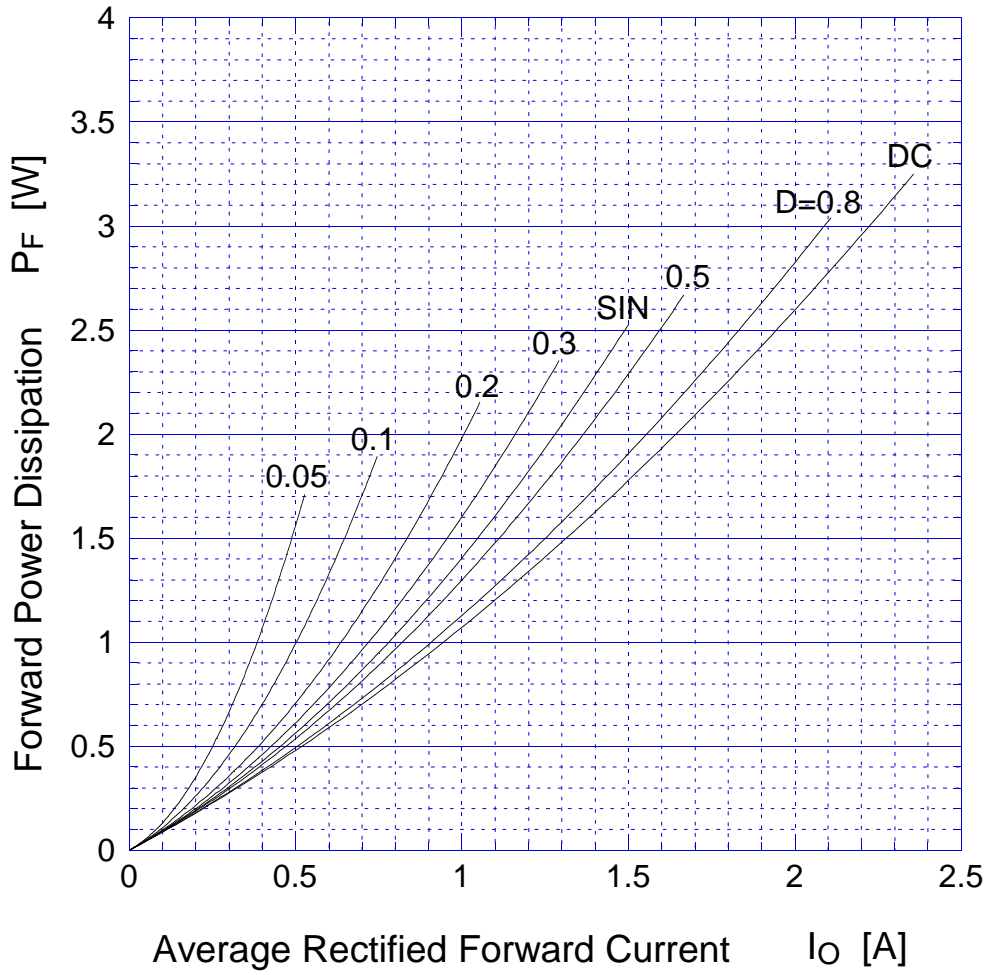

$T_j = 150^\circ\text{C}$

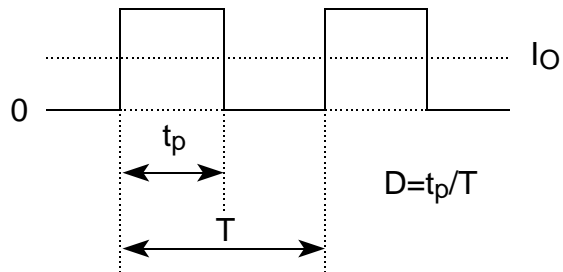

M1FL40

Derating Curve

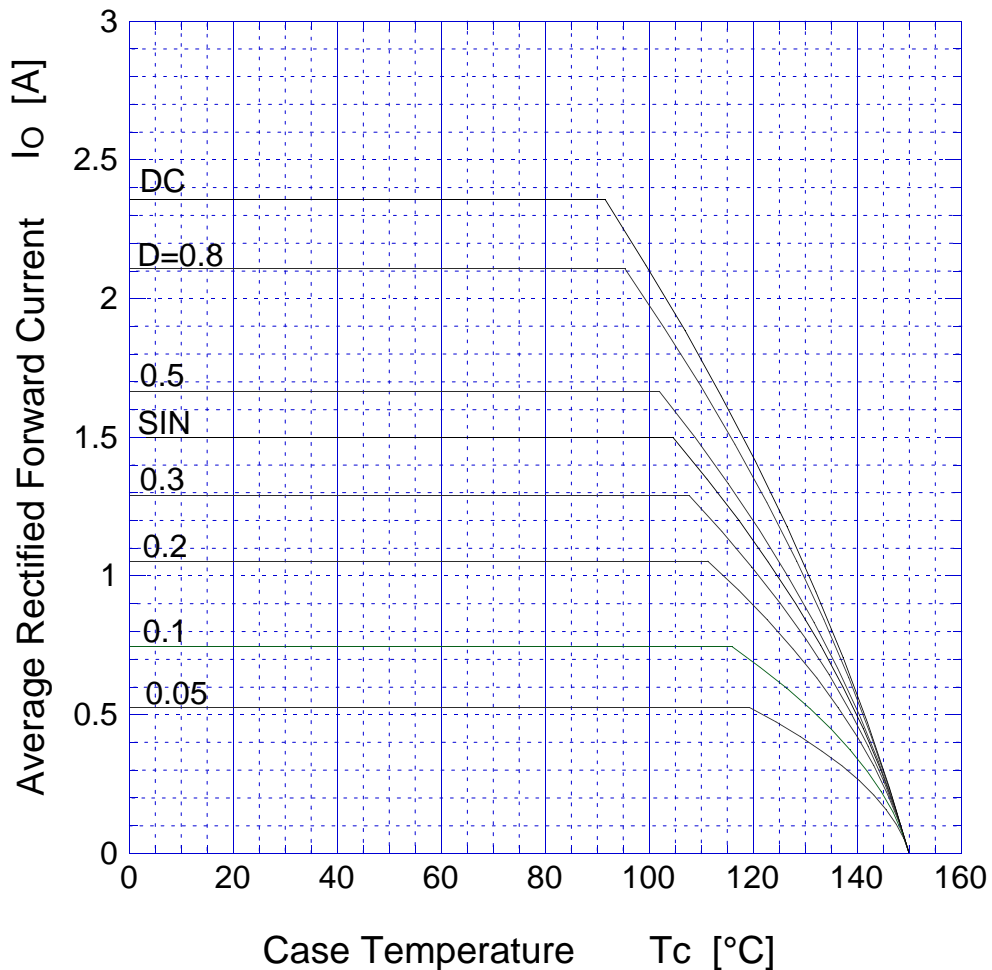

$$V_R = V_{RM}$$

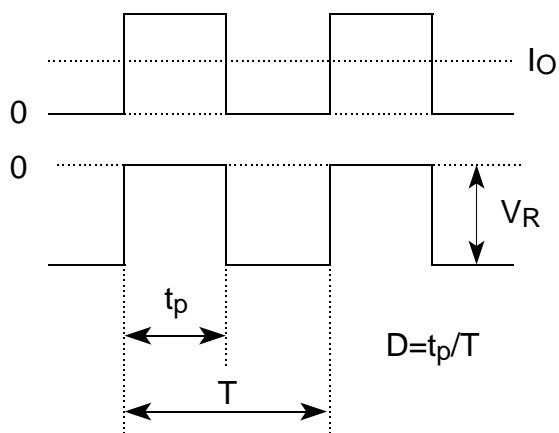

M1FL40

Derating Curve

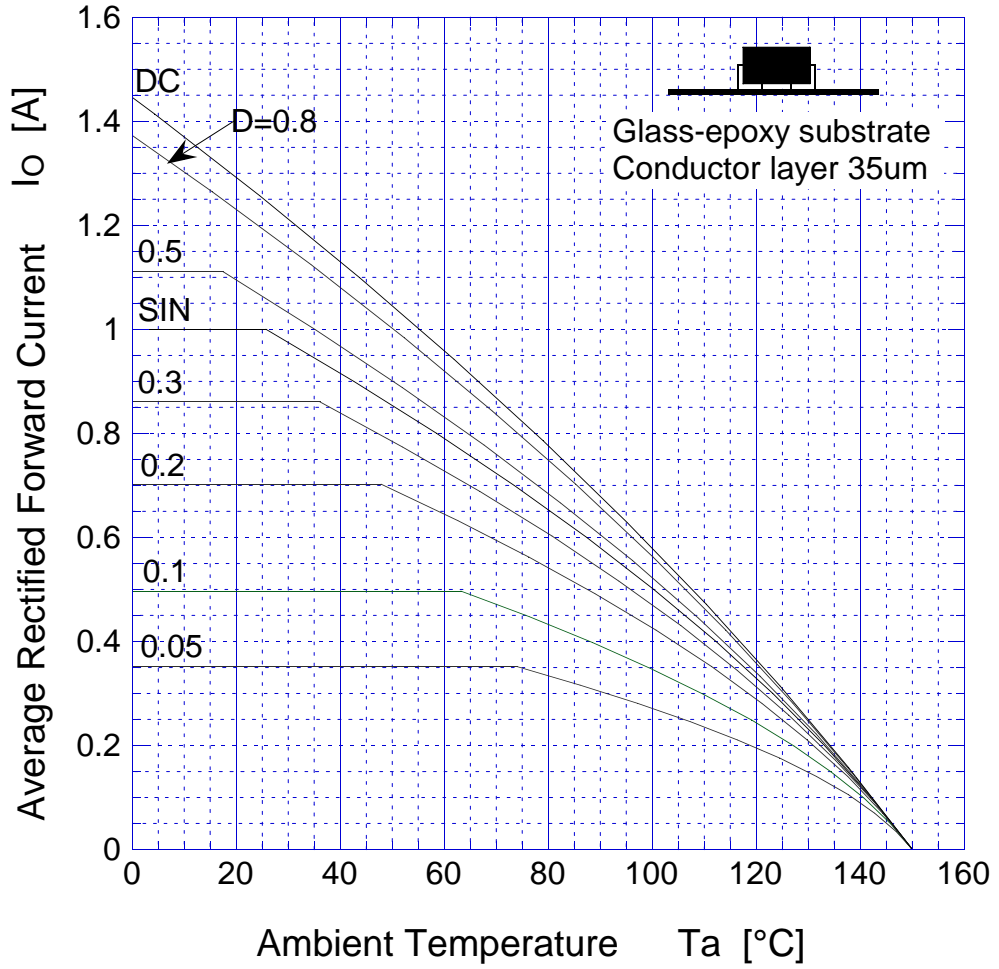

$$V_R = V_{RM}$$

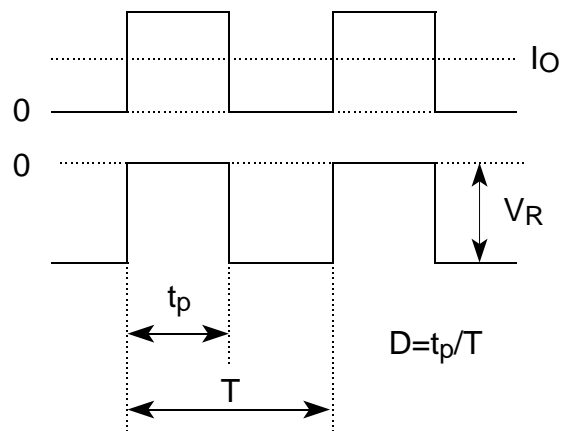

M1FL40 Peak Surge Forward Capability

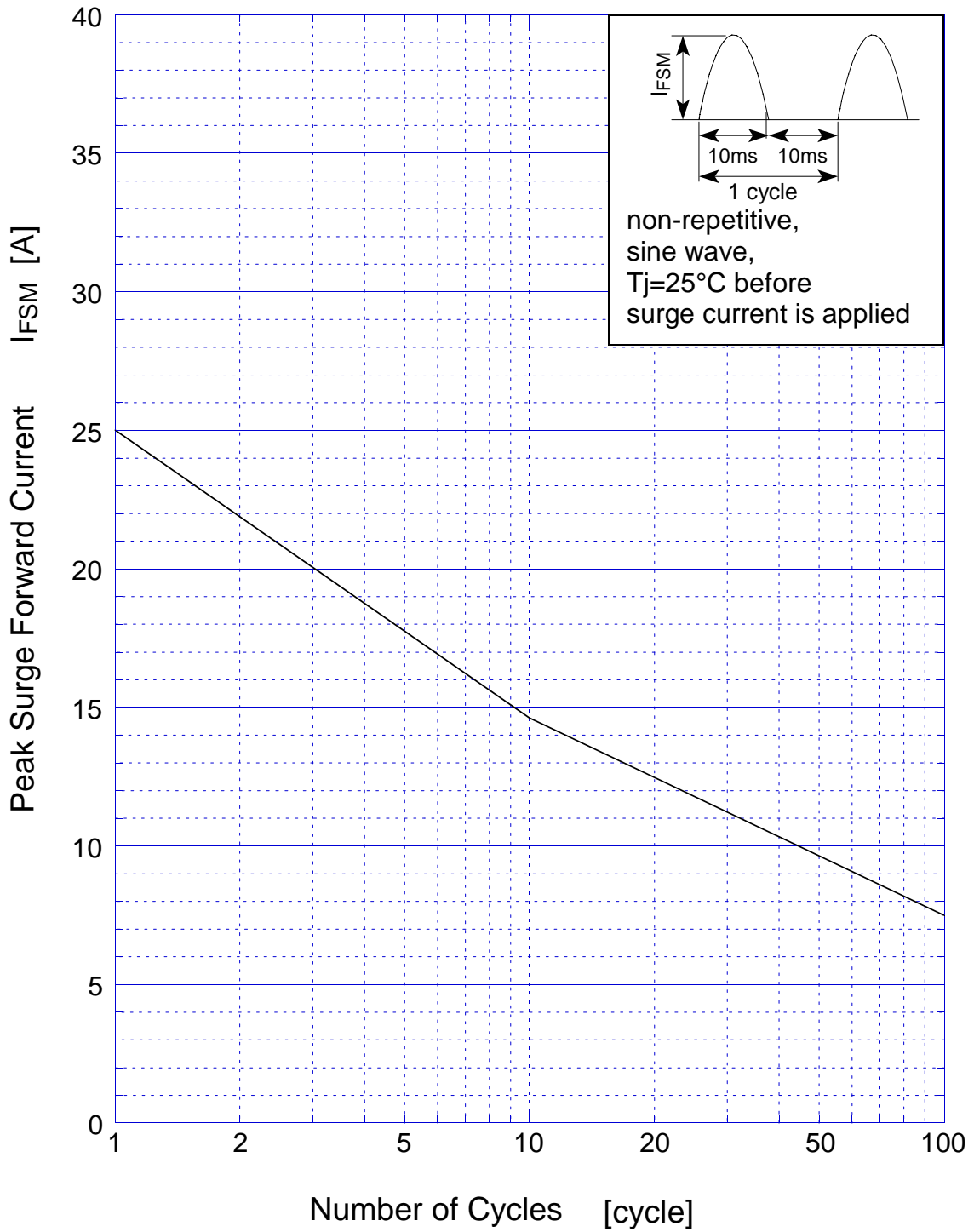

M1FL40 Junction Capacitance

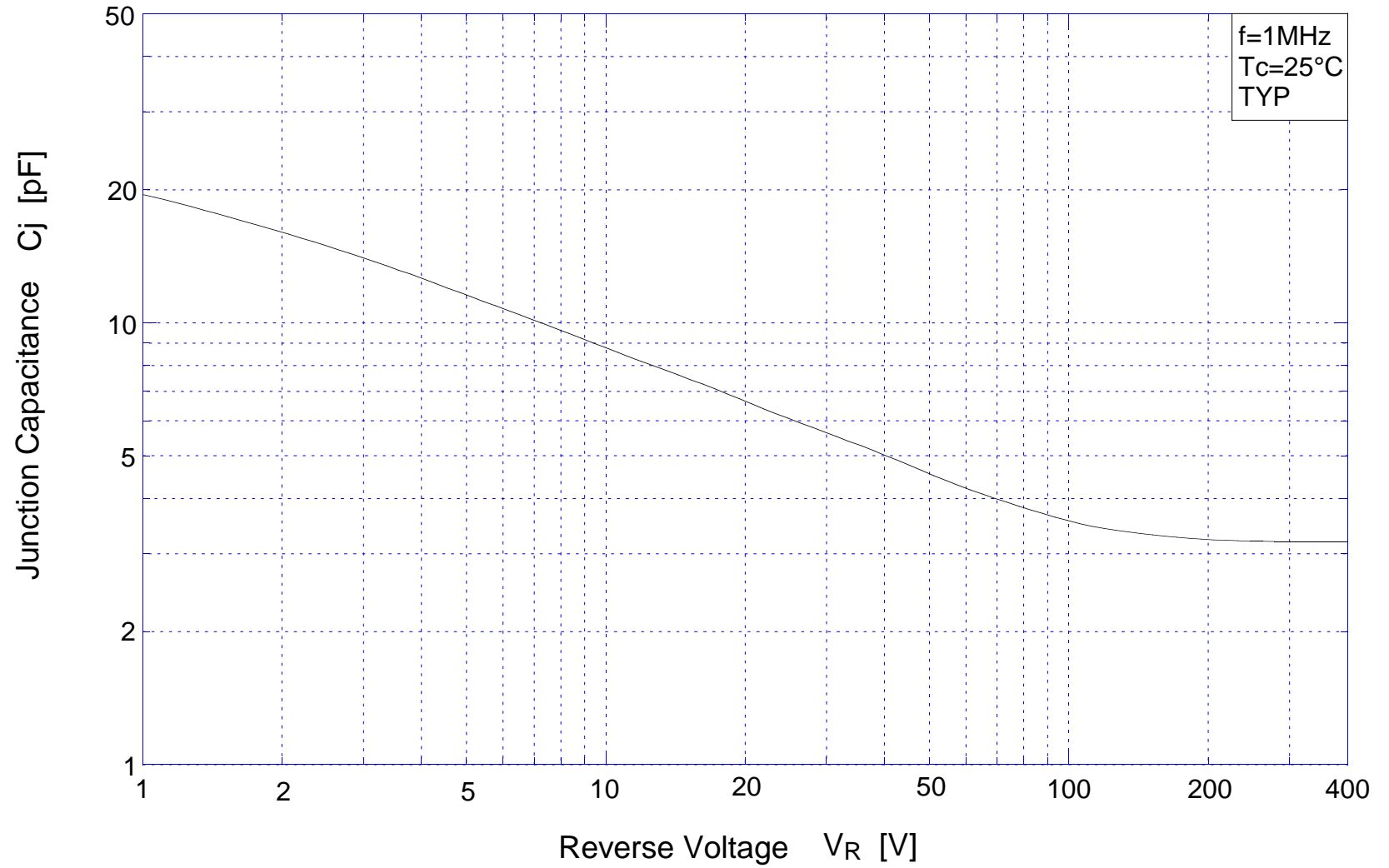

M1FL40 Transient Thermal Impedance

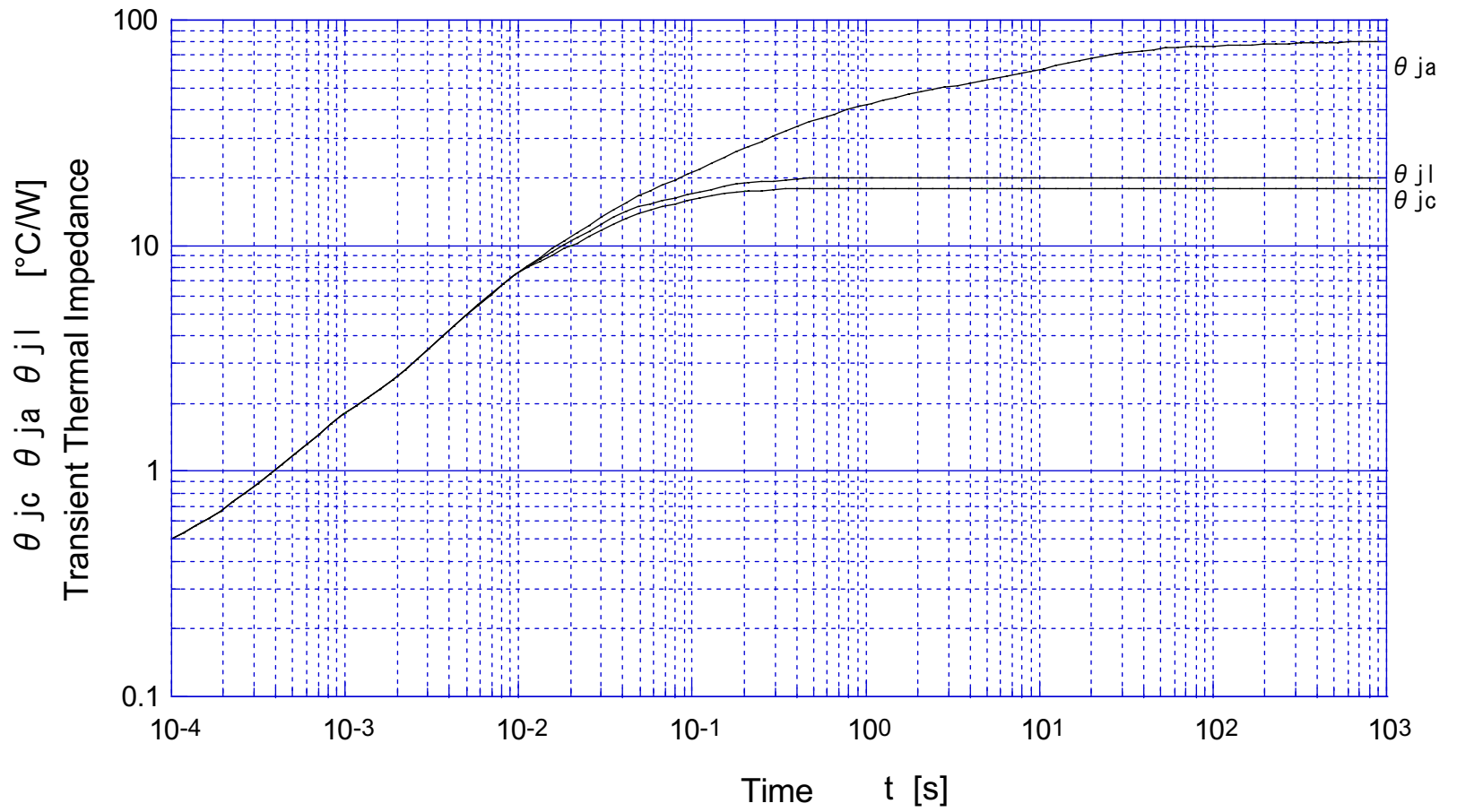

M1FL40 θ_{ja} - Conductor pattern area

