

FSA4157, FSA4157A Low Voltage 1Ω SPDT Analog Switch

Features

- FSA4157A features lower I_{CC} when the S input is lower than V_{CC}
- Maximum 1.15Ω On Resistance (R_{ON}) at 4.5V V_{CC}
- 0.3Ω max R_{ON} flatness at 4.5V V_{CC}
- Space saving 6-lead Pb-Free MicroPak™ and SC70 6-lead surface mount packages
- Broad V_{CC} operating range:
 - FSA4157: 1.65V to 5.5V
 - FSA4157A: 2.7V to 5.5V
- Fast turn-on and turn-off time
- Break-before-make enable circuitry
- Over-voltage tolerant TTL compatible control circuitry

General Description

FSA4157 and FSA4157A are high performance Single Pole/Double Throw (SPDT) analog switches. Both devices feature ultra low R_{ON} of 1.15Ω maximum at 4.5V V_{CC} and will operate over the wide V_{CC} range of 1.65V to 5.5V for FSA4157, and 2.7V to 5.5V for FSA4157A. The device is fabricated with sub-micron CMOS technology to achieve fast switching speeds and is designed for break-before-make operation. The select input is TTL level compatible.

The FSA4157A features very low quiescent current even when the control voltage is lower than the V_{CC} supply. This feature services the mobile handset applications very well allowing for the direct interface with baseband processor general purpose I/Os.

Technology Description

The Fairchild Switch family derives from and embodies Fairchild's proven switch technology used for several years in its 74LVXL384 (FST3384) bus switch product.

Ordering Information

Order Number	Package Number	Product Code Top Mark	Package Description	Supplied As
FSA4157P6	MAA06A	A57	6-Lead SC70, EIAJ SC88, 1.25mm Wide	250 Units on Tape and Reel
FSA4157P6X	MAA06A	A57	6-Lead SC70, EIAJ SC88, 1.25mm Wide	3k Units on Tape and Reel
FSA4157P6X_NL ⁽¹⁾	MAA06A	A57	Pb-Free 6-Lead SC70, EIAJ SC88, 1.25mm Wide	3k Units on Tape and Reel
FSA4157L6X	MAC06A	EG	Pb-Free 6-Lead MicroPak, 1.0mm Wide	5k Units on Tape and Reel
FSA4157AP6	MAA06A	B57	6-Lead SC70, EIAJ SC88, 1.25mm Wide	250 Units on Tape and Reel
FSA4157AP6X	MAA06A	B57	6-Lead SC70, EIAJ SC88, 1.25mm Wide	3k Units on Tape and Reel
FSA4157AP6X_NL ⁽¹⁾	MAA06A	B57	Pb-Free 6-Lead SC70, EIAJ SC88, 1.25mm Wide	3k Units on Tape and Reel
FSA4157AL6X	MAC06A	EU	Pb-Free 6-Lead MicroPak, 1.0mm Wide	5k Units on Tape and Reel

Pb-Free package per JEDEC J-STD-020B.

Note:

1. "_NL" indicates lead-free package (per JEDEC J-STD-020B). Device available in Tape and Reel only.

MicroPak™ is a trademark of Fairchild Semiconductor Corporation.

Analog Symbols

Pin Assignment for SC70

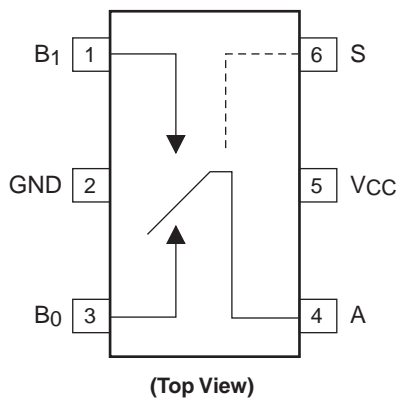

Pin Assignment for MicroPak

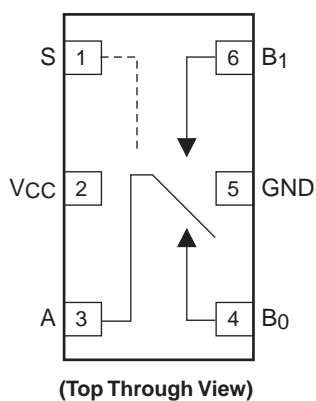

Truth Table

Control Input(s)	Function
L	B ₀ Connected to A
H	B ₁ Connected to A

H = HIGH Logic Level

L = LOW Logic Level

Pin Descriptions

Pin Names	Function
A, B ₀ , B ₁	Data Ports
S	Control Input

Absolute Maximum Ratings

The “Absolute Maximum Ratings” are those values beyond which the safety of the device cannot be guaranteed. The device should not be operated at these limits. The parametric values defined in the Electrical Characteristics tables are not guaranteed at the absolute maximum ratings. The “Recommended Operating Conditions” table will define the conditions for actual device operation.

Symbol	Parameter	Rating
V _{CC}	Supply Voltage	–0.5V to +6.0V
	DC Switch Voltage ⁽²⁾	–0.5V to V _{CC} +0.5V
V _{IN}	DC Input Voltage ⁽²⁾	–0.5V to +6.0V
	DC Input Diode Current	–50mA
	Switch Current	200mA
	Peak Switch Current (Pulse at 1mS duration, <10% Duty Cycle)	400mA
P _D	Power Dissipation @ 85°C	
	SC70 6L Package MicroPak 6L Package	180mW 180mW
T _{STG}	Storage Temperature Range	–65°C to +150°C
T _J	Maximum Junction Temperature	+150°C
T _L	Lead Temperature (Soldering, 10 seconds)	+260°C
	ESD (Human Body Model) FSA4157A	7500V

Recommended Operating Conditions⁽³⁾

Symbol	Parameter	Rating
V _{CC}	Supply Voltage	
	FSA4157 FSA4157A	1.65V to 5.5V 2.7V to 5.5V
	Control Input Voltage	0V to V _{CC}
	Switch Input Voltage	0V to V _{CC}
	Operating Temperature	–40°C to +85°C
	Thermal Resistance θ_{JA} in still air	
	SC70 6L Package MicroPak 6L Package	350°C/W 330°C/W (estimated)

Notes:

- The input and output negative ratings may be exceeded if the input and output diode current ratings are observed.
- Control input must be held HIGH or LOW and it must not float.

DC Electrical Characteristics

(All typical values are @ 25°C unless otherwise specified)

Symbol	Parameter	Conditions	V _{CC} (V)	T _A =					Units
				+25°C			-40°C to +85°C		
				Min.	Typ.	Max.	Min.	Max.	
V _{IH}	Input Voltage High		2.7 to 3.6	–	–	–	2.0	–	V
			4.5 to 5.5	–	–	–	2.4	–	
V _{IL}	Input Voltage Low	(FSA4157A Only)	2.7 to 3.6	–	–	–	–	0.4	V
			2.7 to 3.6	–	–	–	–	0.6	
			4.5 to 5.5	–	–	–	–	0.8	
I _{IN}	Control Input Leakage	V _{IN} = 0V to V _{CC}	2.7 to 3.6	–	–	–	–1.0	1.0	μA
			4.5 to 5.5	–	–	–	–1.0	1.0	
I _{NO(OFF)} , I _{NC(OFF)}	OFF Leakage Current of Port B ₀ and B ₁	A = 1V, 4.5V, B ₀ or B ₁ = 4.5V, 1V	5.5	–2.0	–	2.0	–20.0	20.0	nA
I _{A(ON)}	ON Leakage Current of Port A	A = 1V, 4.5V, B ₀ or B ₁ = 1V, 4.5V or Floating	5.5	–4.0	–	4.0	–40.0	40.0	nA
R _{ON}	Switch ON Resistance ⁽⁴⁾	I _{OUT} = 100mA, B ₀ or B ₁ = 1.5V	2.7	–	2.6	4.0	–	4.3	Ω
		I _{OUT} = 100mA, B ₀ or B ₁ = 3.5V	4.5	–	0.95	1.15	–	1.3	
ΔR _{ON}	On Resistance Matching Between Channels ⁽⁵⁾	I _{OUT} = 100mA, B ₀ or B ₁ = 1.5V	4.5	–	0.06	0.12	–	0.15	Ω
R _{FLAT(ON)}	On Resistance Flatness ⁽⁶⁾	I _{OUT} = 100mA, B ₀ or B ₁ = 0V, 0.75V, 1.5V	2.7	–	1.4	–	–	–	Ω
		I _{OUT} = 100mA, B ₀ or B ₁ = 0V, 1V, 2V	4.5	–	0.2	0.3	–	0.4	
I _{CC}	Quiescent Supply Current	V _{IN} = 0V or V _{CC} , I _{OUT} = 0V	3.6	–	0.1	0.5	–	1.0	μA
			5.5	–	0.1	0.5	–	1.0	
ΔI _{CC}	Increase in I _{CC} per Input	One Input at 2.7V, others at V _{CC} or GND (FSA4157A only)	4.3	–	0.2	–	–	10.0	μA

Notes:

- Measured by the voltage drop between A and B pins at the indicated current through the switch. On Resistance is determined by the lower of the voltage on the two (A or B Ports).
- ΔR_{ON} = R_{ON max} – R_{ON min} measured at identical V_{CC}, temperature and voltage.
- Flatness is defined as the difference between the maximum and minimum value of On Resistance over the specified range of conditions.

AC Electrical Characteristics

(All typical values are @ 25°C unless otherwise specified)

Symbol	Parameter	Conditions	V _{CC} (V)	T _A =					Units	Figure
				+25°C			-40°C to +85°C			
				Min.	Typ.	Max.	Min.	Max.		
t _{ON}	Turn ON Time	B ₀ or B ₁ = 1.5V, R _L = 50Ω, C _L = 35pF (FSA4157A only)	2.7 to 3.6	-	-	60.0	-	65.0	ns	Figure 6
		B ₀ or B ₁ = 1.5V, R _L = 50Ω, C _L = 35pF	2.7 to 3.6	-	-	50.0	-	60.0		
		B ₀ or B ₁ = 3V, R _L = 50Ω, C _L = 35pF	4.5 to 5.5	-	-	35.0	-	40.0		
t _{OFF}	Turn OFF Time	B ₀ or B ₁ = 1.5V, R _L = 50Ω, C _L = 35pF	2.7 to 3.6	-	-	20.0	-	30.0	ns	Figure 6
		B ₀ or B ₁ = 3V, R _L = 50Ω, C _L = 35pF	4.5 to 5.5	-	-	15.0	-	20.0		
t _{B-M}	Break Before Make Time	(FSA4157A only)	2.7 to 3.6	-	-	-	-	-	ns	Figure 10
			4.5 to 5.5	-	20.0	-	-	-		
			4.5 to 5.5	-	25.0	-	-	-		
Q	Charge Injection	C _L = 1.0nF, V _{GE} = 0V, R _{GEN} = 0Ω	2.7 to 3.6	-	10.0	-	-	-	pC	Figure 9
			4.5 to 5.5	-	20.0	-	-	-		
OIRR	OFF-Isolation	f = 1MHz, R _L = 50Ω	2.7 to 3.6	-	-70.0	-	-	-	dB	Figure 8
			4.5 to 5.5	-	-70.0	-	-	-		
Xtalk	Crosstalk	f = 1MHz, R _L = 50Ω	2.7 to 3.6	-	-70.0	-	-	-	dB	Figure 8
			4.5 to 5.5	-	-70.0	-	-	-		
BW	-3db Bandwidth	R _L = 50Ω	2.7 to 3.6	-	300	-	-	-	MHz	Figure 11
			4.5 to 5.5	-	300	-	-	-		
THD	Total Harmonic Distortion	R _L = 600Ω, V _{IN} = 0.5V P.P, f = 20Hz to 20kHz	2.7 to 3.6	-	0.002	-	-	-	%	Figure 12
			4.5 to 5.5	-	0.002	-	-	-		

Capacitance

Symbol	Parameter	Conditions	V _{CC} (V)	T _A =					Units	Figure Number
				+25°C			40°C to +85°C			
				Min.	Typ.	Max.	Min.	Max.		
C _{IN}	Control Pin Input Capacitance	f = 1MHz	0.0	-	3.5	-	-	-	pF	Figure 10
C _{OFF}	B Port OFF Capacitance	f = 1MHz	4.5	-	12.0	-	-	-	pF	Figure 10
C _{ON}	ON Capacitance	f = 1MHz	4.5	-	40.0	-	-	-	pF	Figure 10

Typical Performance Characteristics

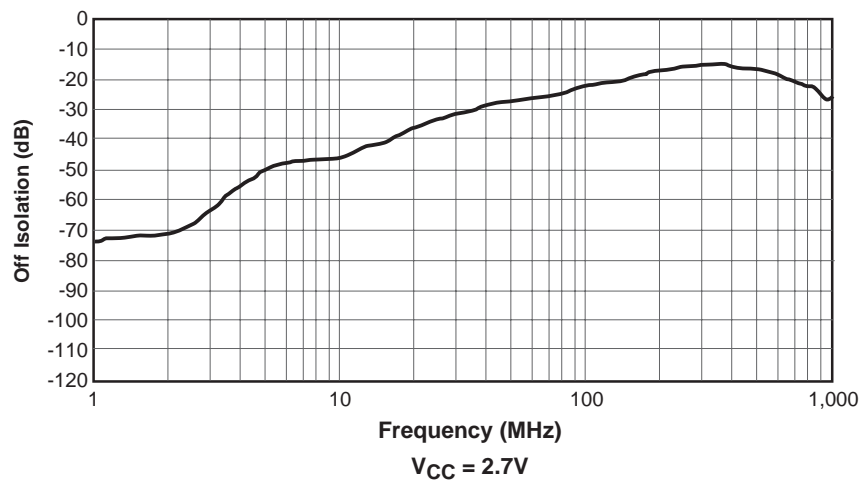

Figure 1. Off-Isolation, $V_{CC} = 2.7V$ to 5.5V

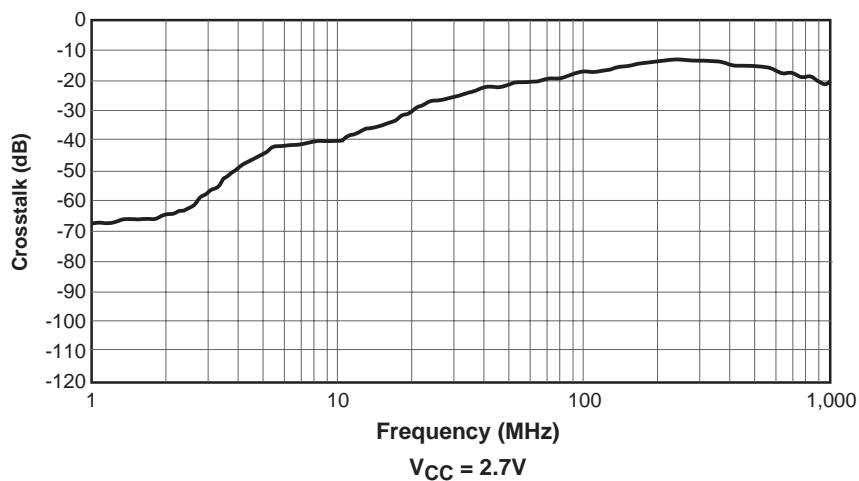

Figure 2. Crosstalk, $V_{CC} = 2.7V$ to 5.5V

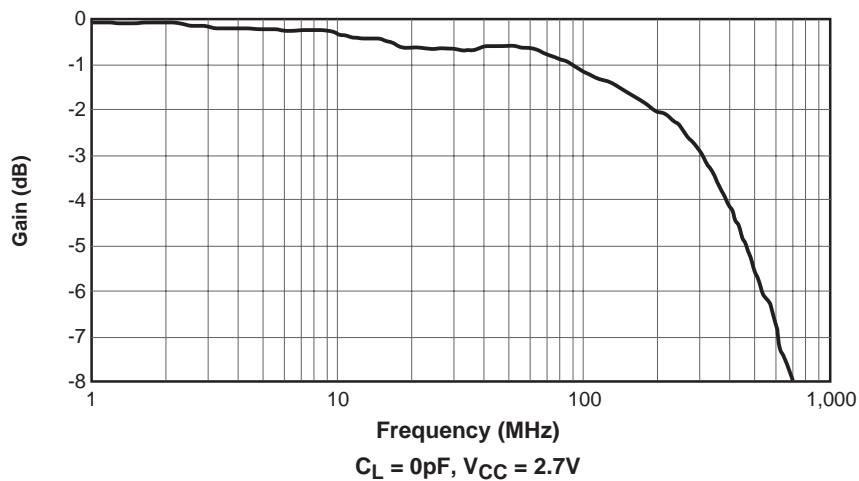

Figure 3. Bandwidth, $V_{CC} = 2.7V$ to 5.5V

Typical Characteristics

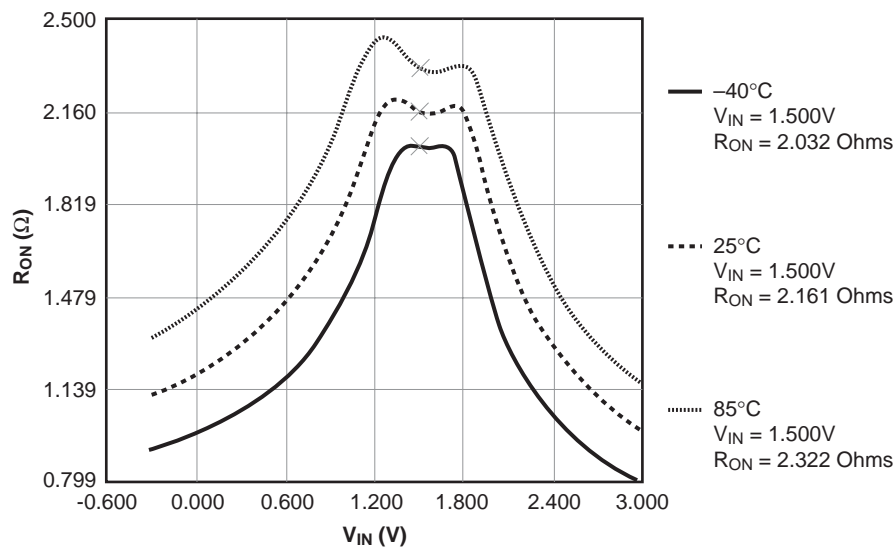

Figure 4. R_{ON} Switch On Resistance, $I_{ON} = 100\text{mA}$, $V_{CC} = 2.7\text{V}$

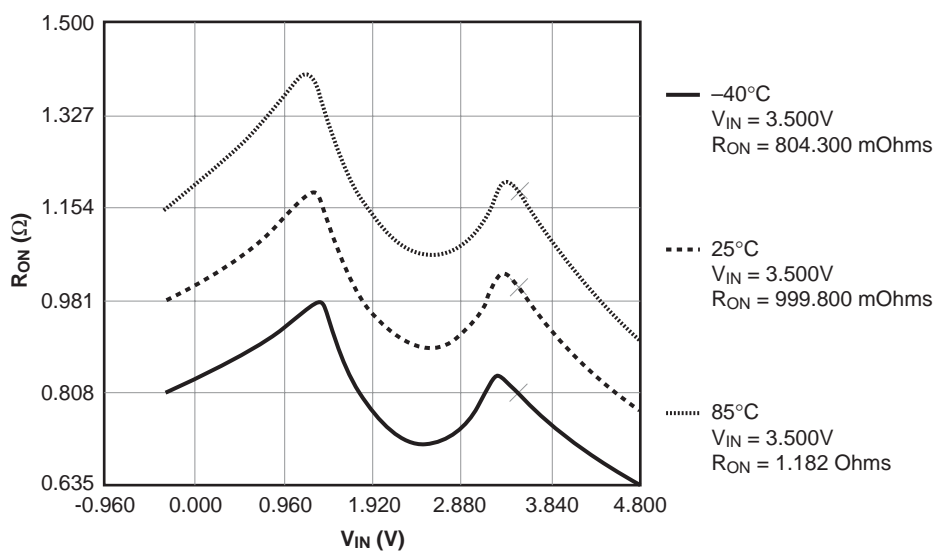

Figure 5. R_{ON} Switch On Resistance, $I_{ON} = 100\text{mA}$, $V_{CC} = 4.5\text{V}$

AC Loading and Waveforms

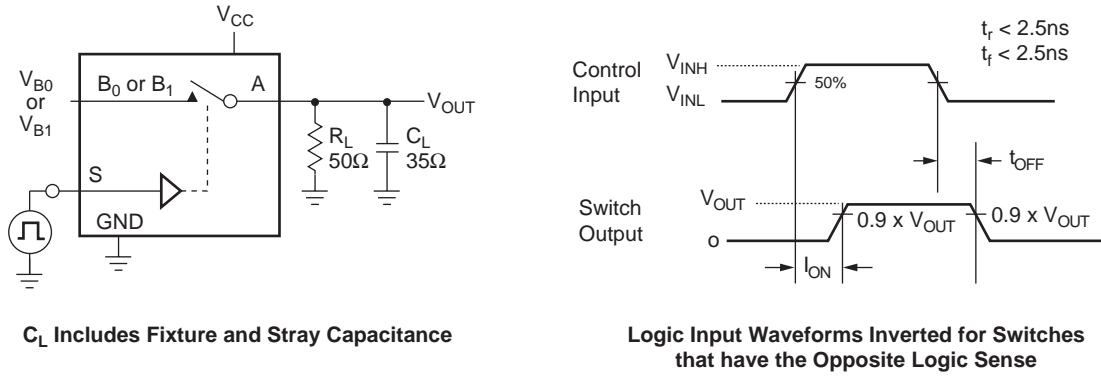

Figure 6. Turn-ON/OFF Timing

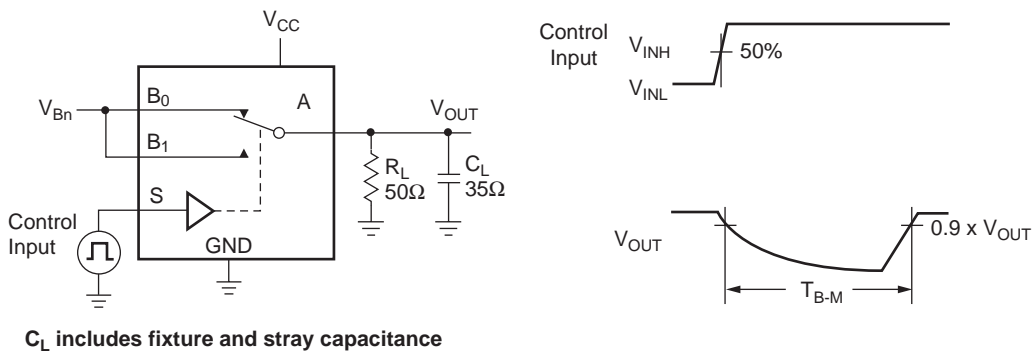

Figure 7. Break Before Make Timing

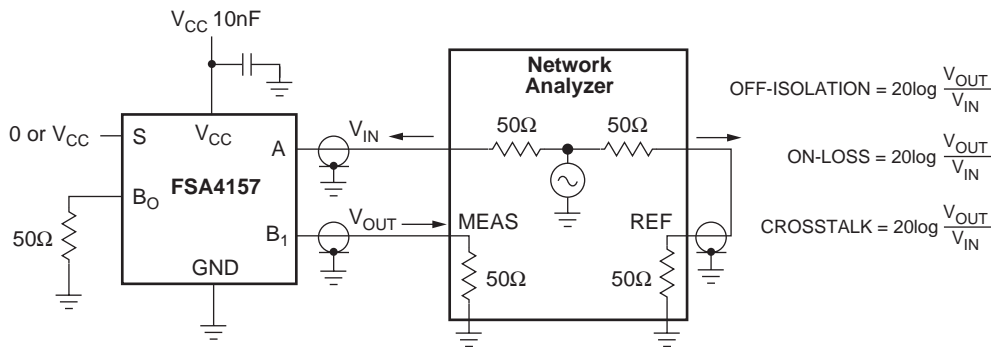

Figure 8. OFF Isolation and Crosstalk

AC Loading and Waveforms (Continued)

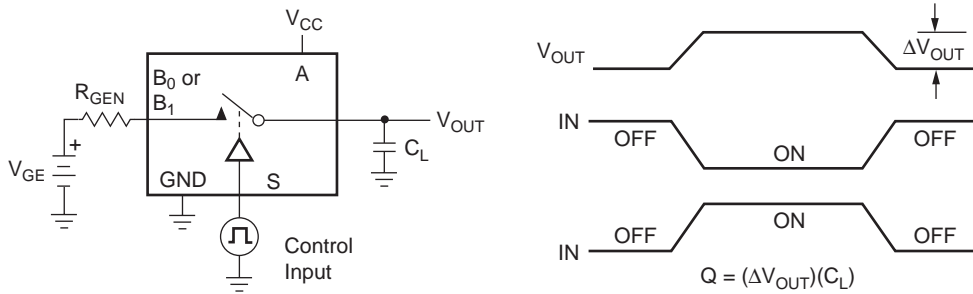

Figure 9. Charge Injection

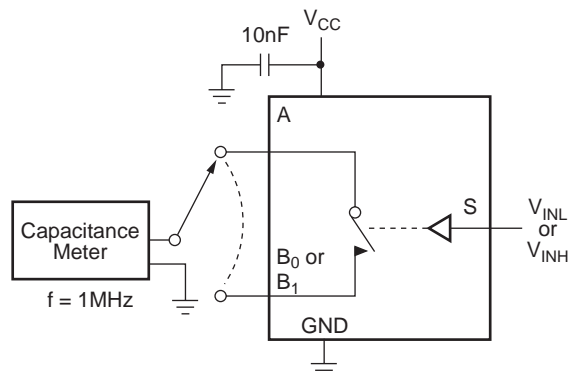

Figure 10. ON/OFF Capacitance Measurement Setup

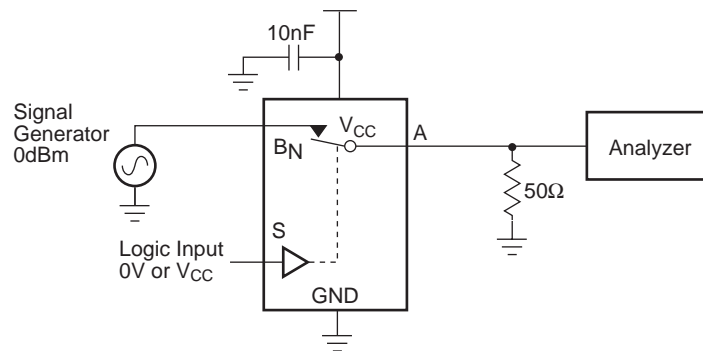

Figure 11. Bandwidth

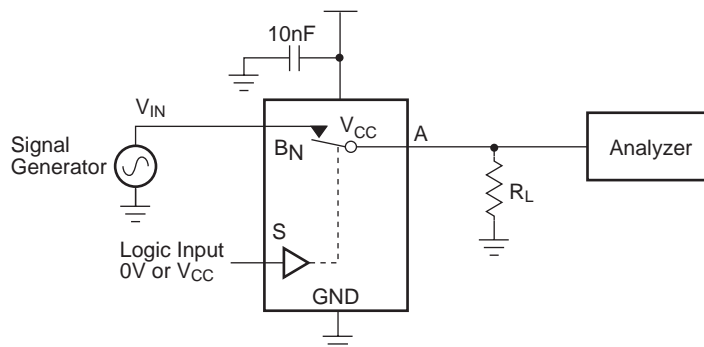
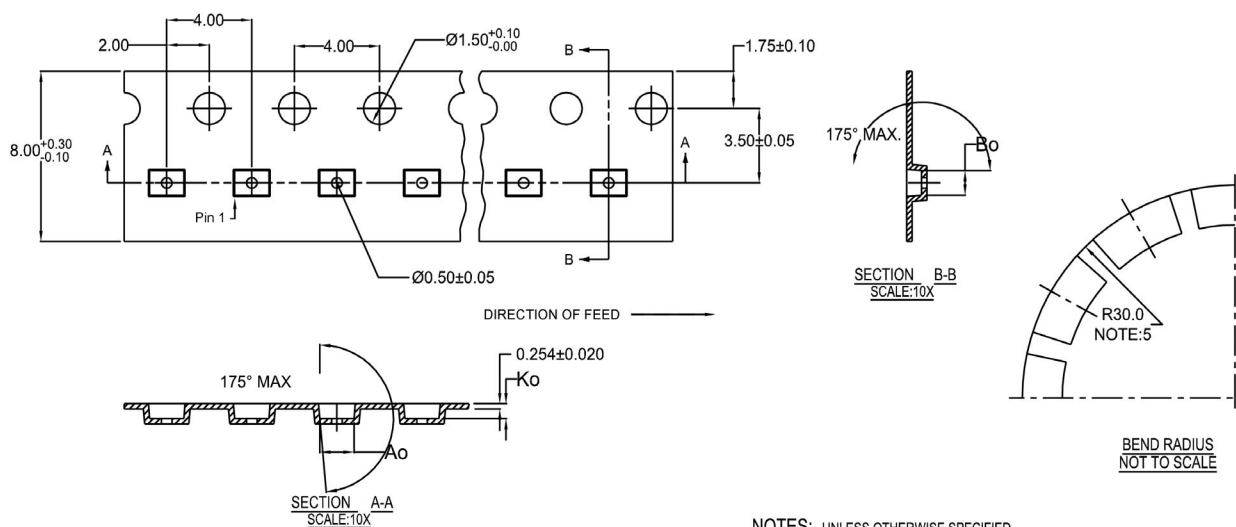

Figure 12. Harmonic Distortion

Tape Specification

Tape Format For Micropak 6

Package Designator	Tape Section	Number Cavities	Cavity Status	Cover Tape Status
L6X	Leader (Start End)	125 (typ)	Empty	Sealed
	Carrier	5000	Filled	Sealed
	Trailer (Hub End)	75 (typ)	Empty	Sealed



10	300056	2.30±0.05	1.78±0.05	0.68±0.05
8	300038	1.78±0.05	1.78±0.05	0.68±0.05
6	300033	1.60±0.05	1.15±0.05	0.70±0.05

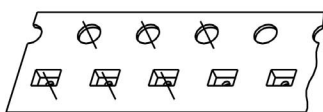

SCALE: 6X

NOTES: UNLESS OTHERWISE SPECIFIED

1. ACCUMULATED 50 SPROCKETS, SPROCKET HOLE PITCH IS 200.00 ±0.30MM
2. NO INDICATED CORNER RADIUS IS 0.127MM
3. CAMBER NOT TO EXCEED 1MM IN 100MM
4. SMALLEST ALLOWABLE BENDING RADIUS
5. POCKET POSITION RELATIVE TO SPROCKET HOLE MEASURED AS TRUE POSITION OF POCKET, NOT POCKET HOLE

Reel Dimensions for Micropack 6 inches (millimeters)

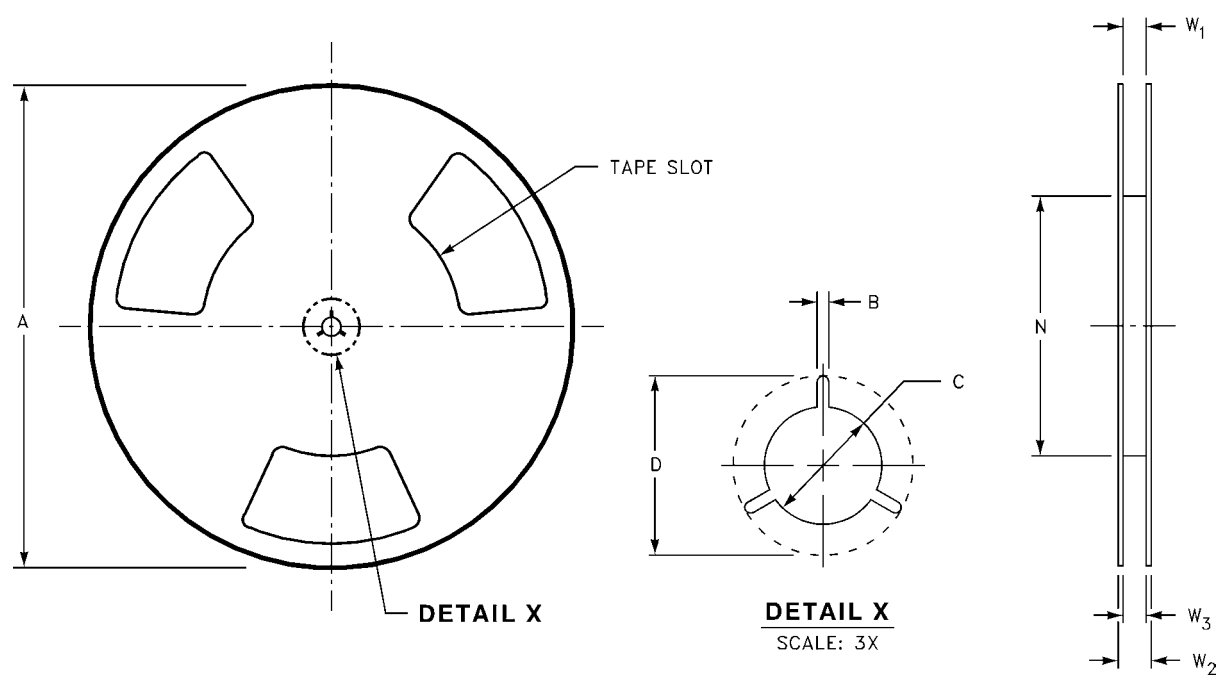

Tape Size	A	B	C	D	N	W1	W2	W3
8 mm	7.0 (177.8)	0.059 (1.50)	0.512 (13.00)	0.795 (20.20)	2.165 (55.00)	0.331 +0.059 / -0.000 (8.40 +1.50 / -0.00)	0.567 (14.40)	W1 +0.078 / -0.039 (W1 +2.00 / -1.00)

Physical Dimensions millimeters unless otherwise noted

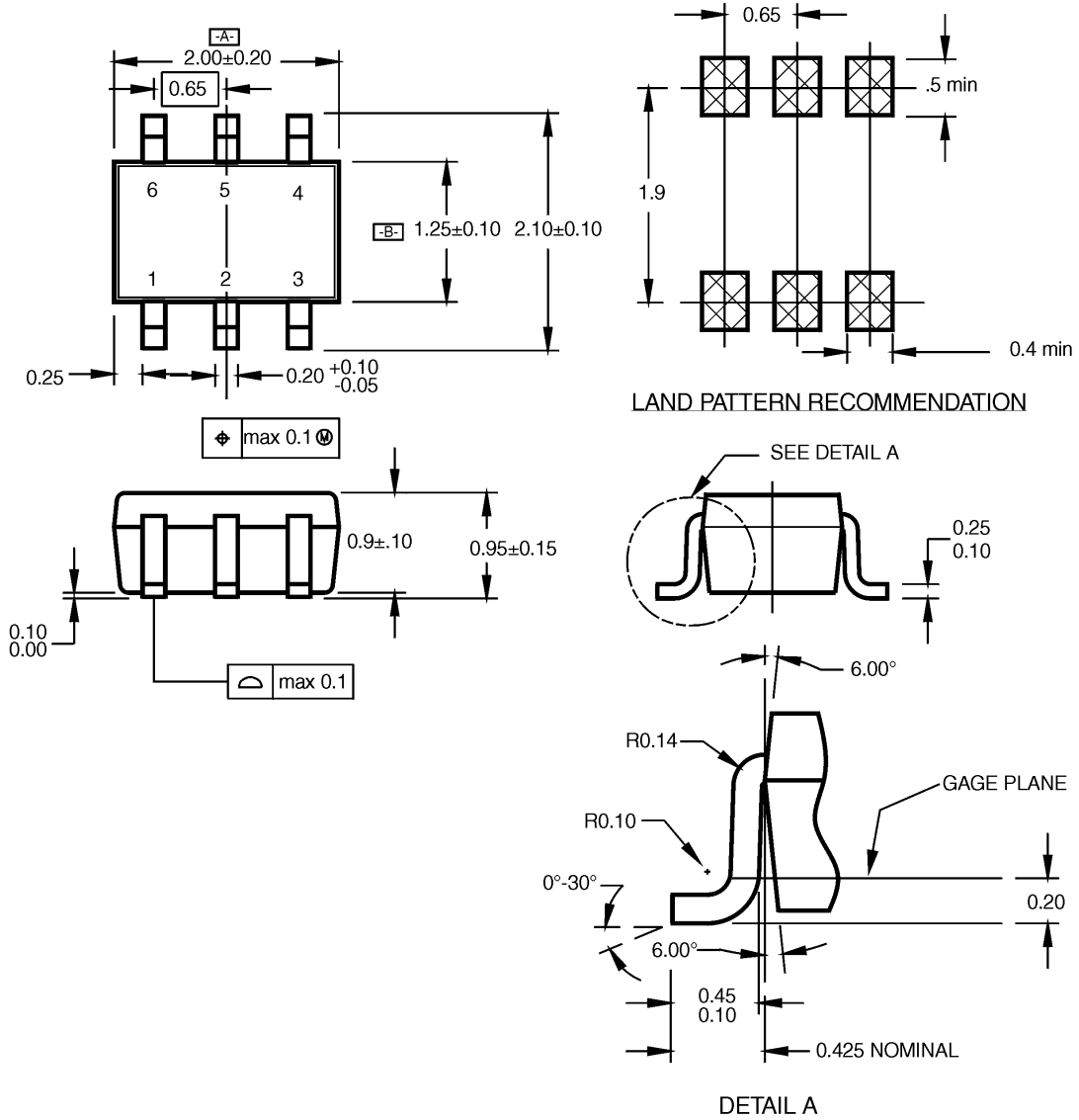

NOTES:

- A. CONFORMS TO EIAJ REGISTERED OUTLINE DRAWING SC88.
- B. DIMENSIONS DO NOT INCLUDE BURRS OR MOLD FLASH.
- C. DIMENSIONS ARE IN MILLIMETERS.

MAA06ARevC

**Pb-Free 6-Lead SC70, EIAJ SC88, 1.25mm Wide
Package Number MAA06A**

Physical Dimensions millimeters unless otherwise noted

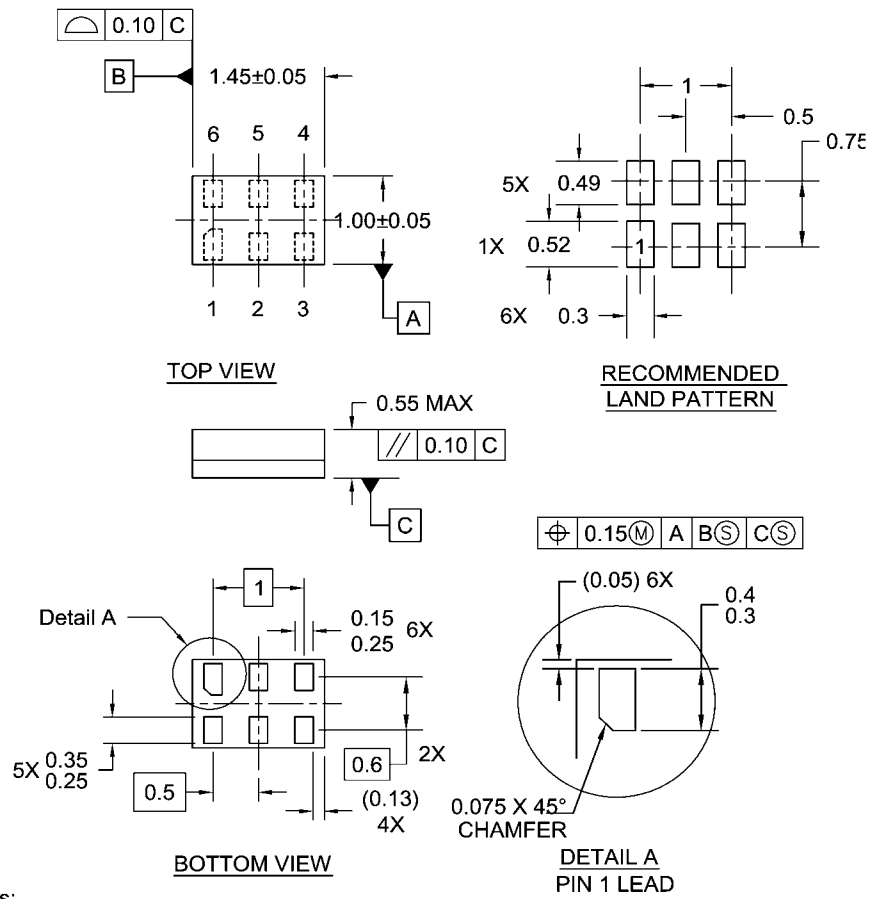

- Notes:
1. JEDEC PACKAGE REGISTRATION IS ANTICIPATED
 2. DIMENSIONS ARE IN MILLIMETERS
 3. DRAWING CONFORMS TO ASME Y14.5M-1994

MAC06ARevB

**Pb-Free 6-Lead MicroPak, 1.0mm Wide
Package Number MAC06A**

TRADEMARKS

The following are registered and unregistered trademarks Fairchild Semiconductor owns or is authorized to use and is not intended to be an exhaustive list of all such trademarks.

ACEx™	FAST®	ISOPLANAR™	PowerSaver™	SuperSOT™-6
ActiveArray™	FASTr™	LittleFET™	PowerTrench®	SuperSOT™-8
Bottomless™	FPST™	MICROCOUPLER™	QFET®	SyncFET™
Build it Now™	FRFET™	MicroFET™	QS™	TCM™
CoolFET™	GlobalOptoisolator™	MicroPak™	QT Optoelectronics™	TinyLogic®
CROSSVOLT™	GTO™	MICROWIRE™	Quiet Series™	TINYOPTO™
DOMET™	HiSeC™	MSX™	RapidConfigure™	TruTranslation™
EcoSPARK™	I ² C™	MSXPro™	RapidConnect™	UHC™
E ² CMOSTM	i-Lo™	OCX™	μSerDes™	UltraFET®
EnSigna™	ImpliedDisconnect™	OCXPro™	ScalarPump™	UniFET™
FACT™	IntelliMAX™	OPTOLOGIC®	SILENT SWITCHER®	VCX™
FACT Quiet Series™		OPTOPLANAR™	SMART START™	Wire™
Across the board. Around the world.™		PACMAN™	SPM™	
The Power Franchise®		POP™	Stealth™	
Programmable Active Droop™		Power247™	SuperFET™	
		PowerEdge™	SuperSOT™-3	

DISCLAIMER

FAIRCHILD SEMICONDUCTOR RESERVES THE RIGHT TO MAKE CHANGES WITHOUT FURTHER NOTICE TO ANY PRODUCTS HEREIN TO IMPROVE RELIABILITY, FUNCTION OR DESIGN. FAIRCHILD DOES NOT ASSUME ANY LIABILITY ARISING OUT OF THE APPLICATION OR USE OF ANY PRODUCT OR CIRCUIT DESCRIBED HEREIN; NEITHER DOES IT CONVEY ANY LICENSE UNDER ITS PATENT RIGHTS, NOR THE RIGHTS OF OTHERS.

LIFE SUPPORT POLICY

FAIRCHILD'S PRODUCTS ARE NOT AUTHORIZED FOR USE AS CRITICAL COMPONENTS IN LIFE SUPPORT DEVICES OR SYSTEMS WITHOUT THE EXPRESS WRITTEN APPROVAL OF FAIRCHILD SEMICONDUCTOR CORPORATION. As used herein:

1. Life support devices or systems are devices or systems which, (a) are intended for surgical implant into the body, or (b) support or sustain life, or (c) whose failure to perform when properly used in accordance with instructions for use provided in the labeling, can be reasonably expected to result in significant injury to the user.
2. A critical component is any component of a life support device or system whose failure to perform can be reasonably expected to cause the failure of the life support device or system, or to affect its safety or effectiveness.

PRODUCT STATUS DEFINITIONS

Definition of Terms

Datasheet Identification	Product Status	Definition
Advance Information	Formative or In Design	This datasheet contains the design specifications for product development. Specifications may change in any manner without notice.
Preliminary	First Production	This datasheet contains preliminary data, and supplementary data will be published at a later date. Fairchild Semiconductor reserves the right to make changes at any time without notice in order to improve design.
No Identification Needed	Full Production	This datasheet contains final specifications. Fairchild Semiconductor reserves the right to make changes at any time without notice in order to improve design.
Obsolete	Not In Production	This datasheet contains specifications on a product that has been discontinued by Fairchild semiconductor. The datasheet is printed for reference information only.

Rev. 118