



0.7Ω, Low-Voltage, Quad 2:1 Analog Multiplexers

MAX4780/MAX4784

General Description

The MAX4780/MAX4784 are low on-resistance, low-voltage, quad 2:1 analog multiplexers that operate from a single +1.6V to +4.2V supply. These devices have fast switching speeds ($t_{ON} = 20ns$, $t_{OFF} = 8ns$), handle rail-to-rail analog signals, and consume less than $1\mu W$ of quiescent power.

When powered from a +2.7V supply, the MAX4780/MAX4784 feature low 0.7Ω on-resistance (R_{ON}), and 0.1Ω R_{ON} flatness (+2.7V Supply).

The MAX4780/MAX4784 are available in 16-pin TSSOP and 3mm x 3mm thin QFN packages.

Applications

- Power Routing
- Battery-Powered Systems
- Audio and Video Signal Routing
- Low-Voltage Data-Acquisition Systems
- Communications Circuits
- PCMCIA Cards
- Cellular Phones
- Modems
- Hard Drives

Features

- ◆ Single-Supply Operation from 1.6V to 4.2V
- ◆ Low R_{ON}
 0.7Ω (+2.7V Supply)
 2Ω (+1.8V Supply)
- ◆ 0.1Ω R_{ON} Flatness (+2.7V Supply)
- ◆ 3mm x 3mm Thin QFN Package
- ◆ +1.8V CMOS Logic Compatible
- ◆ Fast Switching: $t_{ON} = 20ns$, $t_{OFF} = 8ns$

Ordering Information

PART	TEMP RANGE	PIN-PACKAGE
MAX4780ETE	-40°C to +85°C	16 Thin QFN
MAX4780EUE	-40°C to +85°C	16 TSSOP
MAX4784ETE	-40°C to +85°C	16 Thin QFN
MAX4784EUE	-40°C to +85°C	16 TSSOP

Pin Configurations/Functional Diagrams/Truth Tables

TOP VIEW

THIN QFN

MAX4780		
A0	ON SWITCH	
0	NC1, NC2	
1	NO1, NO2	
MAX4784		
EN	A0	ON SWITCH
1	X	NONE
0	0	COM1-NC1 COM2-NC2 COM3-NC3 COM4-NC4
0	1	COM1-NO1 COM2-NO2 COM3-NO3 COM4-NO4

THIN QFN

Pin Configurations/Functional Diagrams/Truth Tables continued at end of data sheet.

0.7 Ω , Low-Voltage, Quad 2:1 Analog Multiplexers

ABSOLUTE MAXIMUM RATINGS

Voltages Referenced to GND

V+, A ₋ , $\overline{\text{EN}}$	-0.3V to +4.6V
COM ₋ , NO ₋ , NC ₋ (Note 1)	-0.3V to (V+ + 0.3V)
Continuous Current COM ₋ , NO ₋ , NC ₋	$\pm 300\text{mA}$
Peak Current COM ₋ , NO ₋ , NC ₋ (pulsed at 1ms 10% duty cycle)	$\pm 500\text{mA}$

Continuous Power Dissipation (T_A = +70°C)

16-Pin Thin QFN (derate 14.7mW/°C above +70°C)	1176.5mW
16-Pin TSSOP (derate 9.4mW/°C above +70°C)	755mW
Operating Temperature Range	-40°C to +85°C
Maximum Junction Temperature	+150°C
Storage Temperature Range	-65°C to +150°C

Note 1: Signals on COM₋, NO₋, or NC₋ exceeding V+ or GND are clamped by internal diodes. Limit forward current to maximum current rating.

Stresses beyond those listed under "Absolute Maximum Ratings" may cause permanent damage to the device. These are stress ratings only, and functional operation of the device at these or any other conditions beyond those indicated in the operational sections of the specifications is not implied. Exposure to absolute maximum rating conditions for extended periods may affect device reliability.

ELECTRICAL CHARACTERISTICS—Single +3V Supply

(V+ = +2.7V to +4.2V, V_{IH} = +1.4V, V_{IL} = +0.5V, T_A = T_{MIN} to T_{MAX}, unless otherwise specified. Typical values are at V+ = +3.0V, T_A = +25°C.) (Notes 2, 3)

PARAMETER	SYMBOL	CONDITIONS	T _A	MIN	TYP	MAX	UNITS
ANALOG SWITCH							
Analog Signal Range	V _{COM-} , V _{NO-} , V _{NC-}			0		V+	V
On-Resistance (Note 4)	R _{ON}	V+ = 2.7V, I _{COM-} = 100mA, V _{NO-} or V _{NC-} = 1.5V	+25°C		0.7	1	Ω
			T _{MIN} to T _{MAX}			1.2	
On-Resistance Match Between Channels (Notes 4, 5)	ΔR_{ON}	V+ = 2.7V, I _{COM-} = 100mA, V _{NO-} or V _{NC-} = 1.5V	+25°C		0.1	0.15	Ω
			T _{MIN} to T _{MAX}			0.2	
On-Resistance Flatness (Note 6)	R _{FLAT(ON)}	V+ = 2.7V, I _{COM-} = 100mA, V _{NO-} or V _{NC-} = 1V, 1.5V, 2V	+25°C		0.1	0.2	Ω
			T _{MIN} to T _{MAX}			0.3	
NO ₋ or NC ₋ Off-Leakage Current (Note 7)	I _{NO-(OFF)} , I _{NC-(OFF)}	V+ = 3.6V, V _{COM-} = 0.3V, 3.3V, V _{NO-} or V _{NC-} = 3.3V, 0.3V	+25°C	-1	± 0.002	+1	nA
			T _{MIN} to T _{MAX}		-5		
COM ₋ Off-Leakage Current (MAX4784 Only) (Note 7)	I _{COM-(OFF)}	V+ = 3.6V, V _{COM-} = 0.3V, 3.3V, V _{NO-} or V _{NC-} = 3.3V, 0.3V, or floating	+25°C	-1	± 0.002	+1	nA
			T _{MIN} to T _{MAX}		-5		
COM ₋ On-Leakage Current (Note 7)	I _{COM-(ON)}	V+ = 3.6V, V _{COM-} = 3.3V, 0.3V, V _{NO-} or V _{NC-} = 3.3V, 0.3V, or floating	+25°C	-2	± 0.002	+2	nA
			T _{MIN} to T _{MAX}		-10		

0.7Ω, Low-Voltage, Quad 2:1 Analog Multiplexers

MAX4780/MAX4784

ELECTRICAL CHARACTERISTICS—Single +3V Supply (continued)

(V₊ = +2.7V to +4.2V, V_{IH} = +1.4V, V_{IL} = +0.5V, T_A = T_{MIN} to T_{MAX}, unless otherwise specified. Typical values are at V₊ = +3.0V, T_A = +25°C.) (Notes 2, 3)

PARAMETER	SYMBOL	CONDITIONS	T _A	MIN	TYP	MAX	UNITS
SWITCH DYNAMIC CHARACTERISTICS							
Turn-On Time	t _{ON}	V _{NO_} , V _{NC_} = 1.5V, R _L = 50Ω, C _L = 35pF, Figure 1	+25°C		20	25	ns
			T _{MIN} to T _{MAX}			30	
Turn-Off Time	t _{OFF}	V _{NO_} , V _{NC_} = 1.5V, R _L = 50Ω, C _L = 35pF, Figure 1	+25°C		8	10	ns
			T _{MIN} to T _{MAX}			18	
Break-Before-Make (Note 8)	t _{BBM}	V _{NO_} , V _{NC_} = 1.5V, R _L = 50Ω, C _L = 35pF, Figure 2	+25°C		7		ns
			T _{MIN} to T _{MAX}		1		
Charge Injection	Q	V _{GEN} = 0, R _{GEN} = 0, C _L = 1.0nF, Figure 3	+25°C		5		pC
NO_ or NC_ Off-Capacitance	C _{OFF}	f = 1MHz, Figure 4	+25°C		33		pF
COM_ Off-Capacitance	C _{COM_(OFF)}	f = 1MHz, Figure 4	+25°C		60		pF
COM_ On-Capacitance	C _{COM_(ON)}	f = 1MHz, Figure 4	+25°C		85		pF
-3dB On-Channel Bandwidth	BW	Signal = 0, R _{IN} = R _{OUT} = 50Ω, C _L = 5pF, Figure 5			123		MHz
Off-Isolation (Note 9)	V _{ISO}	f = 1MHz, V _{COM_} = 1V _{P-P} , R _L = 50Ω, C _L = 5pF, Figure 5	+25°C		-67		dB
Crosstalk (Note 10)	V _{CT}	f = 1MHz, V _{COM_} = 1V _{P-P} , R _L = 50Ω, C _L = 5pF, Figures 4, 5	+25°C		-95		dB
Total Harmonic Distortion	THD	f = 20Hz to 20kHz, V _{COM_} = 2V _{P-P} , R _L = 32Ω	+25°C		0.008		%
LOGIC INPUT (A_, EN)							
Input Logic High	V _{IH}			1.8			V
Input Logic Low	V _{IL}					0.5	V
Input Leakage Current	I _{IN}	V _{EN} = 0 or +3.6V, V _{A0} = 0 or +3.6V		-1	0.005	+1	μA
POWER SUPPLY							
Power-Supply Range	V ₊			1.6		3.6	V
Positive Supply Current	I ₊	V ₊ = 3.6V, EN, A0 = 0 or V ₊ , all channels on or off	T _{MIN} to T _{MAX}			2	μA

0.7Ω, Low-Voltage, Quad 2:1 Analog Multiplexers

ELECTRICAL CHARACTERISTICS—Single +1.8V Supply

(V_F = +1.8V, V_{IH} = +1.0V, V_{IL} = +0.4V, T_A = T_{MIN} to T_{MAX}, unless otherwise specified. Typical values are at T_A = +25°C.)
(Notes 2, 3)

PARAMETER	SYMBOL	CONDITIONS	T _A	MIN	TYP	MAX	UNITS
ANALOG SWITCH							
Analog Signal Range	V _{COM_} , V _{NO_} , V _{NC_}			0		V+	V
On-Resistance	R _{ON}	I _{COM_} = 10mA, V _{NO_} or V _{NC_} = 1.0V	+25°C	2	3		Ω
			T _{MIN} to T _{MAX}			5	
NO_ or NC_ Off-Leakage Current (Note 7)	I _{NO_(OFF)} , I _{NC_(OFF)}	V _{COM_} = 0.3V, 1.5V, V _{NO_} or V _{NC_} = 1.5V, 0.3V	+25°C	-1		+1	nA
			T _{MIN} to T _{MAX}	-5		+5	
COM_ Off-Leakage Current (MAX4784 Only) (Note 7)	I _{COM_(OFF)}	V _{COM_} = 0.3V, 1.5V, V _{NO_} or V _{NC_} = 1.5V, 0.3V	+25°C	-1		+1	nA
			T _{MIN} to T _{MAX}	-5		+5	
COM_ On-Leakage Current (Note 7)	I _{COM_(ON)}	V _{COM_} = 0.3V, 1.5V, V _{NO_} or V _{NC_} = 0.3V, 1.5V, or floating	+25°C	-2		+2	nA
			T _{MIN} to T _{MAX}	-10		+10	
SWITCH DYNAMIC CHARACTERISTICS							
Turn-On Time	t _{ON}	V _{NO_} , V _{NC_} = 1.0V, R _L = 50Ω, C _L = 35pF, Figure 1	+25°C	25	30		ns
			T _{MIN} to T _{MAX}			35	
Turn-Off Time	t _{OFF}	V _{NO_} , V _{NC_} = 1.0V, R _L = 50Ω, C _L = 35pF, Figure 1	+25°C	10	15		ns
			T _{MIN} to T _{MAX}			20	
Break-Before-Make (Note 8)	t _{BBM}	V _{NO_} , V _{NC_} = 1.0V, R _L = 50Ω, C _L = 35pF, Figure 2	+25°C	10			ns
			T _{MIN} to T _{MAX}	1			
Charge Injection	Q	V _{GEN} = 0, R _{GEN} = 0, C _L = 1nF, Figure 3	+25°C		5		pC

0.7Ω, Low-Voltage, Quad 2:1 Analog Multiplexers

MAX4780/MAX4784

ELECTRICAL CHARACTERISTICS—Single +1.8V Supply (continued)

www.datasheet4u.com

($V_+ = +1.8V$, $V_{IH} = +1.0V$, $V_{IL} = +0.4V$, $T_A = T_{MIN}$ to T_{MAX} , unless otherwise specified. Typical values are at $T_A = +25^\circ C$.) (Notes 2, 3)

PARAMETER	SYMBOL	CONDITIONS	T_A	MIN	TYP	MAX	UNITS
LOGIC INPUT (A₋, \overline{EN})							
Input Logic High	V_{IH}			1.8			V
Input Logic Low	V_{IL}					0.4	V
Input Leakage Current	I_{IN}	$V_{\overline{EN}} = 0$ or $+3.6V$, $V_{A0} = 0$ or $+3.6V$		-1		+1	μA

- Note 2:** The algebraic convention, where the most negative value is a minimum and the most positive value is a maximum, is used in this data sheet.
- Note 3:** $-40^\circ C$ specifications are guaranteed by design.
- Note 4:** R_{ON} and ΔR_{ON} matching specifications for QFN packaged parts are guaranteed by design.
- Note 5:** $\Delta R_{ON} = R_{ON(MAX)} - R_{ON(MIN)}$.
- Note 6:** Flatness is defined as the difference between the maximum and the minimum value of on-resistance as measured over the specified analog signal ranges.
- Note 7:** Leakage parameters are 100% tested at $T_A = +85^\circ C$, and guaranteed by correlation over the full rated temperature range.
- Note 8:** Guaranteed by design.
- Note 9:** Off-isolation = $20 \log_{10}(V_{COM_}/V_{NO_})$, $V_{COM_}$ = output, $V_{NO_}$ = input to off switch.
- Note 10:** Between two switches.
- Note 11:** Parts are guaranteed to 1 million cycles of operation. (Cycle = switch on → switch off → switch on.)
- Note 12:** The minimum load resistance is 8Ω . (See the *Typical Application Circuit*.)

Typical Operating Characteristics

($T_A = +25^\circ C$, unless otherwise noted.)

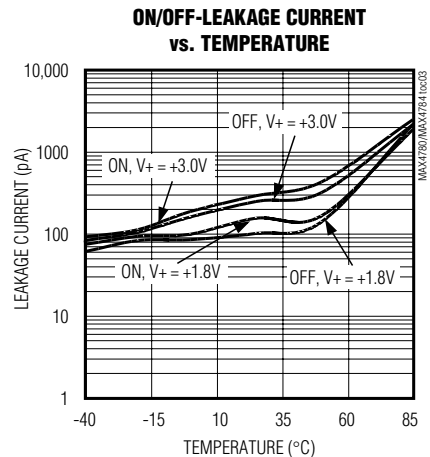
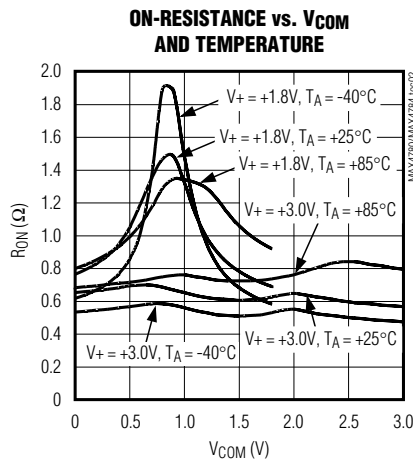
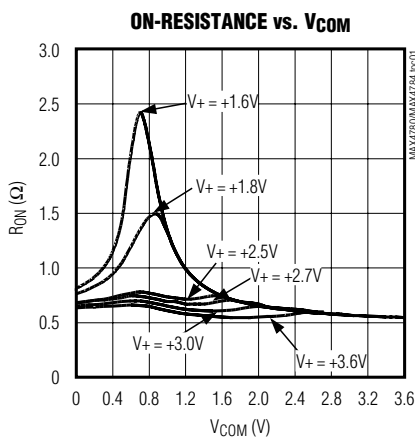

0.7Ω, Low-Voltage, Quad 2:1 Analog Multiplexers

Typical Operating Characteristics (continued)

($T_A = +25^\circ\text{C}$, unless otherwise noted.)

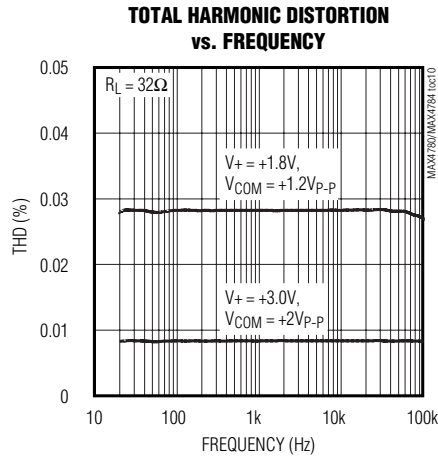
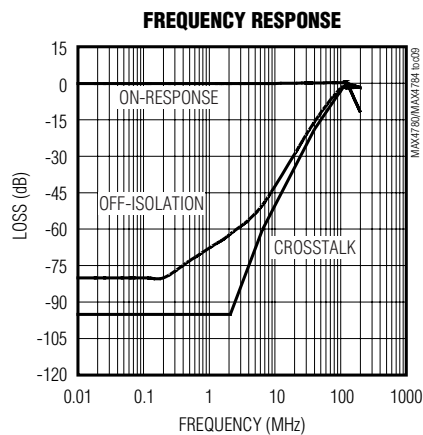
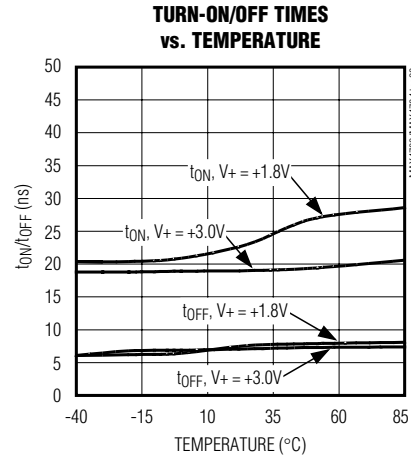
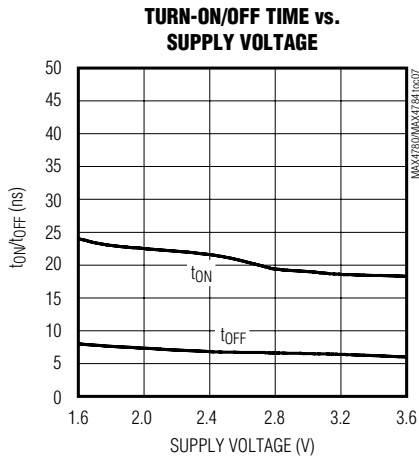
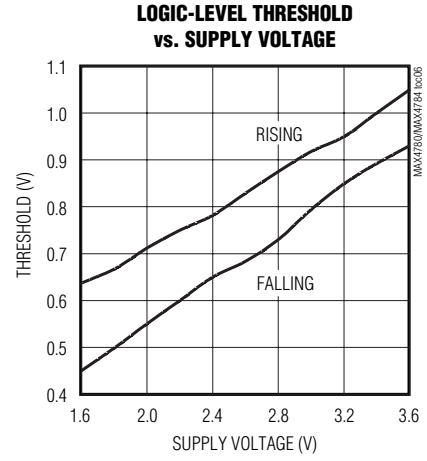
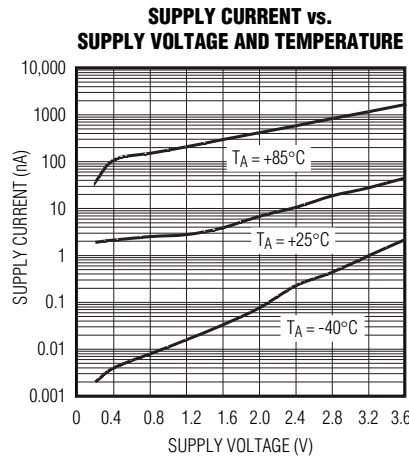
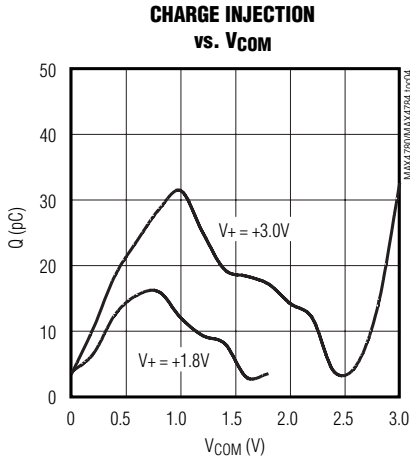

0.7Ω, Low-Voltage, Quad 2:1 Analog Multiplexers

Pin Description

www.datasheet4u.com

MAX4780/MAX4784

PIN				NAME	FUNCTION
MAX4780		MAX4784			
TSSOP	THIN QFN	TSSOP	THIN QFN		
1	15	1	15	A0	Address Input
2	16	2	16	NC1	Normally Closed Terminal
3	1	3	1	NO1	Normally Open Terminal
4	2	4	2	COM1	Analog Switch Common Terminal
5	3	5	3	NC2	Normally Closed Terminal
6	4	6	4	NO2	Normally Open Terminal
7	5	7	5	COM2	Analog Switch Common Terminal
8	6	8	6	GND	Ground
9	7	9	7	COM3	Analog Switch Common Terminal
10	8	10	8	NO3	Normally Open Terminal
11	9	11	9	NC3	Normally Closed Terminal
12	10	12	10	COM4	Analog Switch Common Terminal
13	11	13	11	NO4	Normally Open Terminal
14	12	14	12	NC4	Normally Closed Terminal
15	13	—	—	A1	Address Input
—	—	15	13	\overline{EN}	Enable. Connect to GND for normal operation. Connect to logic-level high to turn all switches off.
16	14	16	14	V+	Positive Supply Voltage

Detailed Description

The MAX4780/MAX4784 are low 0.7Ω (at V+ = +2.7V) on-resistance, low-voltage, quad 2:1 analog multiplexers/demultiplexers that operate from a +1.6V to +4.2V single supply. CMOS switch construction allows switching analog signals that are within the supply voltage range (GND to V+).

When powered from a +2.7V supply, the 0.7Ω RON allows high continuous currents to be switched in a variety of applications.

Applications Information

Proper power-supply sequencing is recommended for all CMOS devices. Do not exceed the absolute maximum ratings, because stresses beyond the listed ratings can cause permanent damage to the devices. Always sequence V+ on first, followed by NO_, NC_, or COM_.

Although it is not required, power-supply bypassing improves noise margin and prevents switching noise propagation from the V+ supply to other components. A 0.1μF capacitor, connected from V+ to GND, is adequate for most applications.

Typical Application Circuit

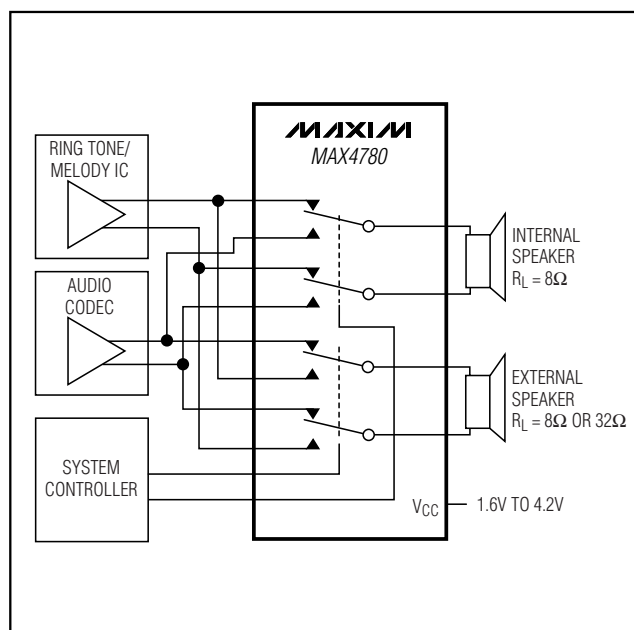

0.7Ω, Low-Voltage, Quad 2:1 Analog Multiplexers

Logic Inputs

The MAX4780/MAX4784 logic inputs can be driven up to +4.2V regardless of the supply voltage. For example, with a +1.8V supply, A₋ and $\overline{\text{EN}}$ may be driven low to GND and high to +4.2V. Driving A₋ and $\overline{\text{EN}}$ rail-to-rail minimizes power consumption. Drive $\overline{\text{EN}}$ low to enable the COM₋ outputs. When $\overline{\text{EN}}$ is high, the COM₋ outputs are high impedance.

Analog Signal Levels

Analog signals that range over the entire supply voltage (V₊ to GND) can be passed with very little change in on-

resistance (see the *Typical Operating Characteristics*). The switches are bidirectional, so the NO₋, NC₋, and COM₋ pins can be used as either inputs or outputs.

Layout

High-speed switches require proper layout and design procedures for optimum performance. Reduce stray inductance and capacitance by keeping traces short and wide. Ensure that bypass capacitors are as close to the device as possible. Use large ground planes where possible.

Test Circuits/Timing Diagrams

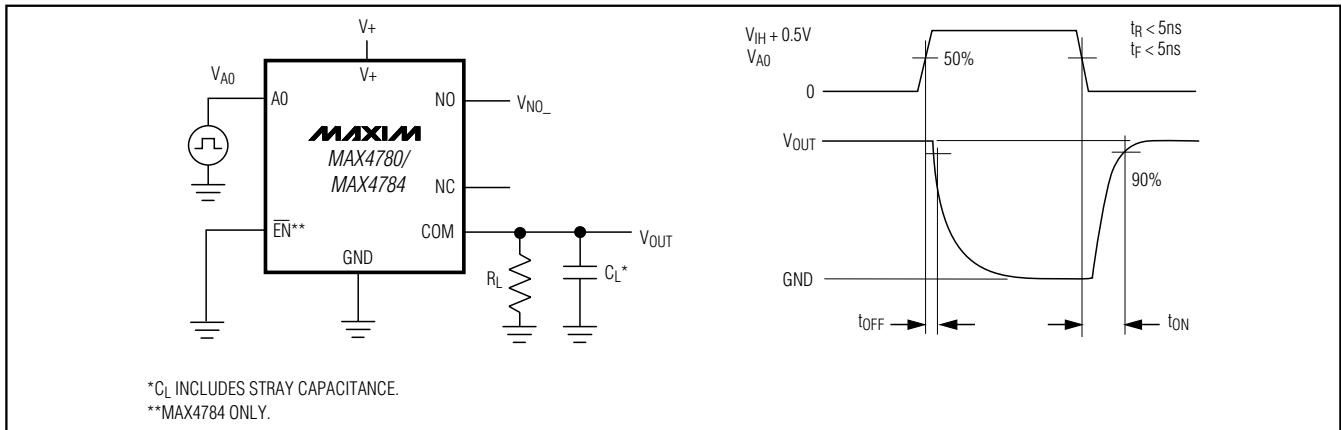

Figure 1. Turn-On and Turn-Off Times

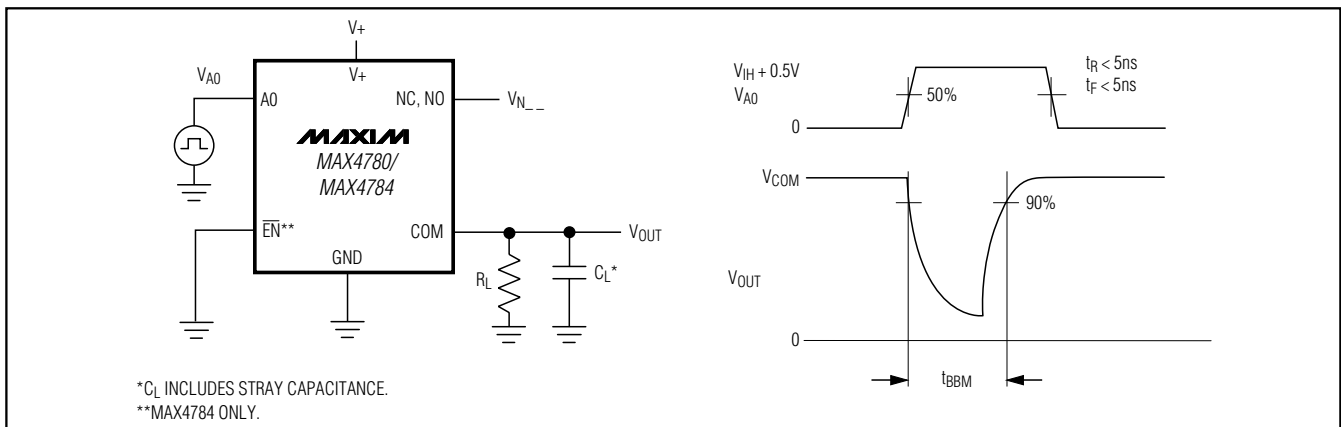

Figure 2. Break-Before-Make Interval

0.7Ω, Low-Voltage, Quad 2:1 Analog Multiplexers

Test Circuits/Timing Diagrams (continued)

MAX4780/MAX4784

www.datasheet4u.com

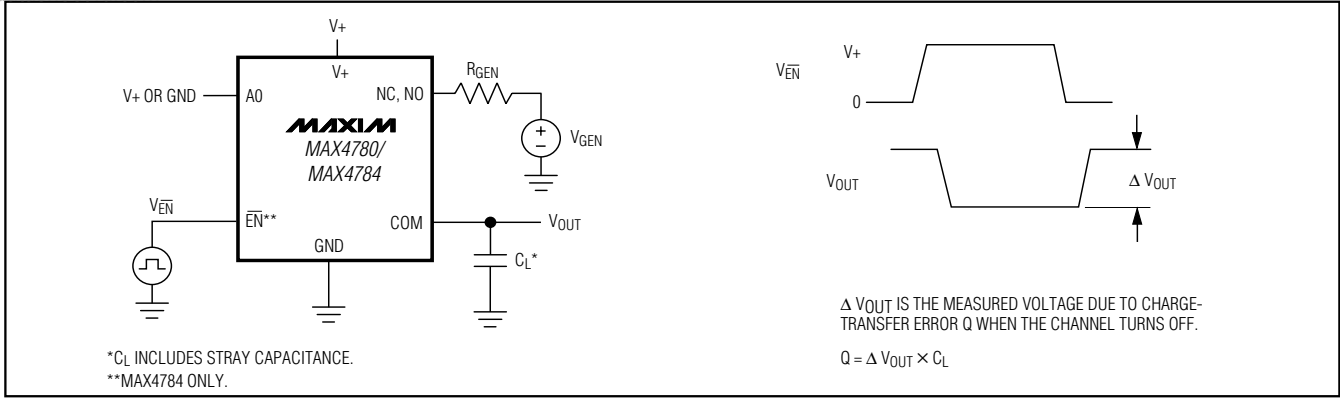

Figure 3. Charge Injection

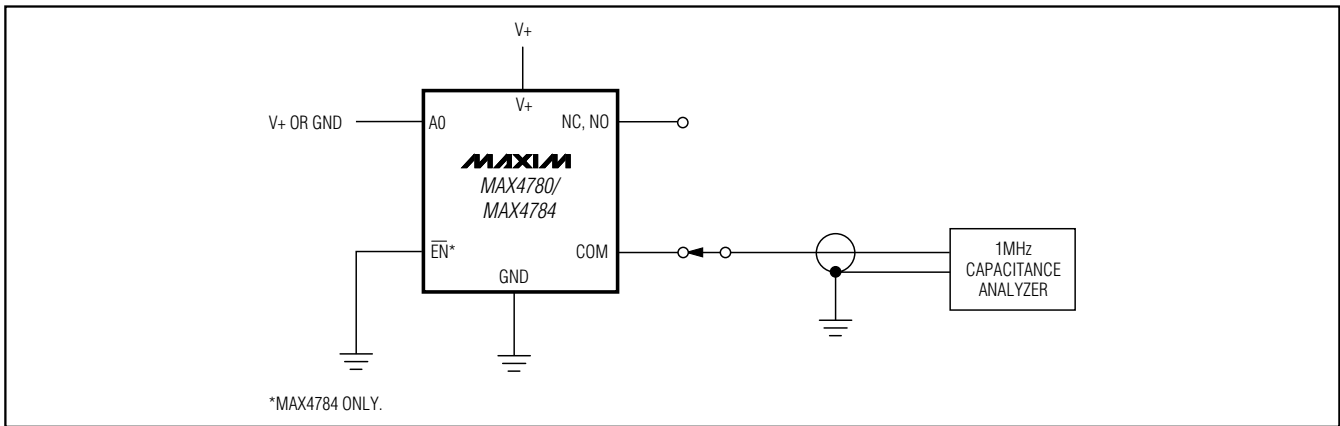

Figure 4. Capacitance

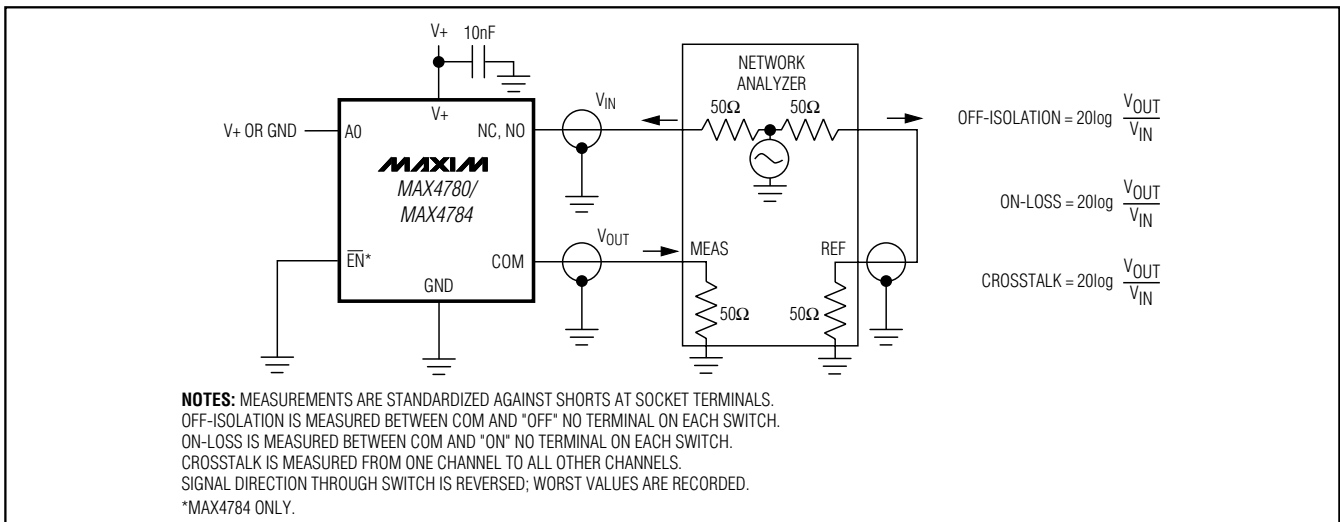
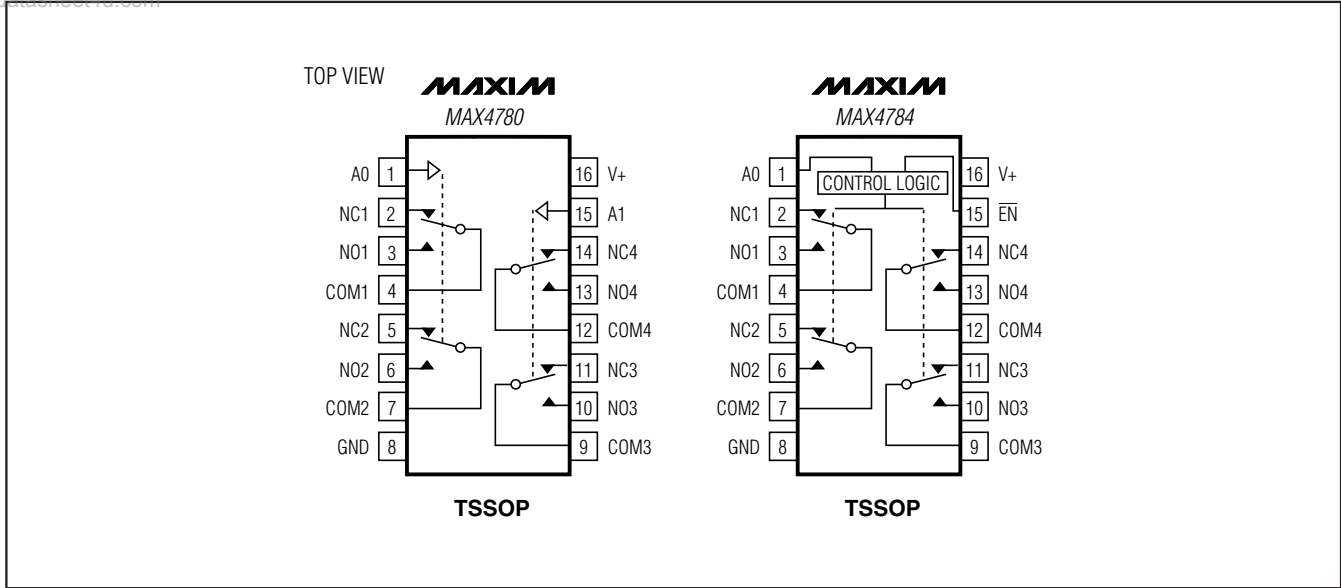

Figure 5. Off-Isolation, On-Loss, and Crosstalk

0.7Ω, Low-Voltage, Quad 2:1 Analog Multiplexers

Pin Configurations/Functional Diagrams/Truth Tables (continued)



Chip Information

TRANSISTOR COUNT: 543
 PROCESS: CMOS

0.7Ω, Low-Voltage, Quad 2:1 Analog Multiplexers

Package Information

(The package drawing(s) in this data sheet may not reflect the most current specifications. For the latest package outline information, go to www.maxim-ic.com/packages.)

SYMBOL	COMMON DIMENSIONS			
	MILLIMETERS		INCHES	
	MIN.	MAX.	MIN.	MAX.
A	—	1.10	—	.043
A ₁	0.05	0.15	.002	.006
A ₂	0.85	0.95	.033	.037
b	0.19	0.30	.007	.012
b ₁	0.19	0.25	.007	.010
c	0.09	0.20	.004	.008
c ₁	0.09	0.14	.004	.006
D	SEE VARIATIONS		SEE VARIATIONS	
E	4.30	4.50	.169	.177
e	0.65 BSC		.026 BSC	
H	6.25	6.55	.246	.258
L	0.50	0.70	.020	.028
N	SEE VARIATIONS		SEE VARIATIONS	
α	0°	8°	0°	8°

JEDEC	N	MILLIMETERS	INCHES			
			MIN.	MAX.		
AB-1	14	D	4.90	5.10	.193	.201
AB	16	D	4.90	5.10	.193	.201
AC	20	D	6.40	6.60	.252	.260
AD	24	D	7.70	7.90	.303	.311
AE	28	D	9.60	9.80	.378	.386

NOTES:

- DIMENSIONS D AND E DO NOT INCLUDE FLASH
- MOLD FLASH OR PROTRUSIONS NOT TO EXCEED 0.15mm PER SIDE
- CONTROLLING DIMENSION: MILLIMETER
- MEETS JEDEC OUTLINE MD-153. SEE JEDEC VARIATIONS TABLE
- "N" REFERS TO NUMBER OF LEADS
- THE LEAD TIPS MUST LIE WITHIN A SPECIFIED ZONE. THIS TOLERANCE ZONE IS DEFINED BY TWO PARALLEL PLANES. ONE PLANE IS THE SEATING PLANE, DATUM [-C-]; THE OTHER PLANE IS AT THE SPECIFIED DISTANCE FROM [-C-] IN THE DIRECTION INDICATED

TSSOP4.40mm.EPS

MAX4780/MAX4784

0.7Ω, Low-Voltage, Quad 2:1 Analog Multiplexers

Package Information (continued)

www.data-sheet4u.com

(The package drawing(s) in this data sheet may not reflect the most current specifications. For the latest package outline information, go to www.maxim-ic.com/packages.)

MAX4780/MAX4784

PKG REF.	12L 3x3			16L 3x3		
	MIN.	NOM.	MAX.	MIN.	NOM.	MAX.
A	0.70	0.75	0.80	0.70	0.75	0.80
b	0.20	0.25	0.30	0.20	0.25	0.30
D	2.90	3.00	3.10	2.90	3.00	3.10
E	2.90	3.00	3.10	2.90	3.00	3.10
e	0.50 BSC.			0.50 BSC.		
L	0.45	0.55	0.65	0.30	0.40	0.50
N	12			16		
ND	3			4		
NE	3			4		
A1	0	0.02	0.05	0	0.02	0.05
A2	0.20 REF			0.20 REF		
k	0.25	-	-	0.25	-	-

PKG. CODES	EXPOSED PAD VARIATIONS						PIN ID	JEDEC	DOWN BOND ALLOWED
	D2			E2					
	MIN.	NOM.	MAX.	MIN.	NOM.	MAX.			
T1233-1	0.95	1.10	1.25	0.95	1.10	1.25	0.35 x 45°	WEED-1	NO
T1233-3	0.95	1.10	1.25	0.95	1.10	1.25	0.35 x 45°	WEED-1	YES
T1633-1	0.95	1.10	1.25	0.95	1.10	1.25	0.35 x 45°	WEED-2	NO
T1633-2	0.95	1.10	1.25	0.95	1.10	1.25	0.35 x 45°	WEED-2	YES
T1633F-3	0.65	0.80	0.95	0.65	0.80	0.95	0.225 x 45°	WEED-2	N/A
T1633-4	0.95	1.10	1.25	0.95	1.10	1.25	0.35 x 45°	WEED-2	NO

NOTES:

- DIMENSIONING & TOLERANCING CONFORM TO ASME Y14.5M-1994.
- ALL DIMENSIONS ARE IN MILLIMETERS. ANGLES ARE IN DEGREES.
- N IS THE TOTAL NUMBER OF TERMINALS.
- THE TERMINAL #1 IDENTIFIER AND TERMINAL NUMBERING CONVENTION SHALL CONFORM TO JEDEC 95-1 SPP-012. DETAILS OF TERMINAL #1 IDENTIFIER ARE OPTIONAL, BUT MUST BE LOCATED WITHIN THE ZONE INDICATED. THE TERMINAL #1 IDENTIFIER MAY BE EITHER A MOLD OR MARKED FEATURE.
- DIMENSION b APPLIES TO METALLIZED TERMINAL AND IS MEASURED BETWEEN 0.20 mm AND 0.25 mm FROM TERMINAL TIP.
- ND AND NE REFER TO THE NUMBER OF TERMINALS ON EACH D AND E SIDE RESPECTIVELY.
- DEPOPULATION IS POSSIBLE IN A SYMMETRICAL FASHION.
- COPLANARITY APPLIES TO THE EXPOSED HEAT SINK SLUG AS WELL AS THE TERMINALS.
- DRAWING CONFORMS TO JEDEC MO220 REVISION C.

 	
<small>PROPRIETARY INFORMATION</small>	
TITLE: PACKAGE OUTLINE 12, 16L, THIN QFN, 3x3x0.8mm	
APPROVAL	DOCUMENT CONTROL NO. 21-0136
REV. E	2/2

Maxim cannot assume responsibility for use of any circuitry other than circuitry entirely embodied in a Maxim product. No circuit patent licenses are implied. Maxim reserves the right to change the circuitry and specifications without notice at any time.

Maxim Integrated Products, 120 San Gabriel Drive, Sunnyvale, CA 94086 408-737-7600 13