



NXP ARM Cortex-M0™ microcontrollers LPC1200

Up to 128 KB Flash and configurable peripherals for industrial control

Powered by the smallest, most energy-efficient Cortex-M0 core, the LPC1200 provides compelling solutions for industrial control. The series includes up to 128 KB Flash and 8 KB SRAM, and offers configurable peripherals ideally suited for energy-efficient controls and appliances.

Key features

- ▶ ARM Cortex-M0 processor
 - Up to 30 MHz CPU frequency with zero wait state from Flash
 - Nested Vectored Interrupt Controller (NVIC) supports 32 vectored interrupts with fast and deterministic latency
 - Three reduced-power modes: Sleep, Deep-sleep, and Deep power-down
- ▶ Memories
 - Up to 8 KB SRAM
 - Up to 128 KB Flash memory with 512 Byte page erase
- ▶ Serial communication interfaces
 - Two UARTs with fractional baud-rate generation and internal FIFO plus RS-485, modem, and IrDA supports
 - I²C with Fast-mode Plus for twice the devices on one bus and longer transmission distances
- ▶ SSP (SPI) controller with FIFO and multi-protocol capabilities
- ▶ Analog peripherals
 - 10-bit Analog-to-Digital Converter (ADC) with eight channels and conversion rates up to 400 ksp/s
 - Two comparators, each with up to six selectable external sources, fully configurable on either positive or negative comparator input channels
- ▶ Other peripherals
 - Direct Memory Access (DMA) controller with 21 channels supports onboard UART, SPI, ADC, RTC, counters/timers, comparators, I²C, and GPIO
 - Cyclic Redundancy Check (CRC) engine with programmable polynomial settings and support for several CRC standards
 - Two 32-bit general-purpose counter/timers with four capture inputs and four match outputs
 - Two 16-bit general-purpose counter/timers with two capture inputs and two match outputs
 - Windowed Watchdog Timer (WDT) designed to comply with IEC 60730 Class B safety requirements
 - 32-bit Real-time Clock (RTC)
 - Up to 55 general-purpose I/O (GPIO) pins, all with configurators and a digital filter

Applications

- ▶ White goods
- ▶ Industrial control
- ▶ Home automation
- ▶ Power conversion
- ▶ UPS



- ▶ Lighting
- ▶ Alarm systems
- ▶ PC peripherals
- ▶ POS

General description

The LPC1200 series extends NXP's 32-bit ARM microcontroller continuum by targeting a wide range of industrial applications in the areas of factory and home automation. The series offers a wide range of Flash memory sizes, from 32 to 128 KB, with 512 Bytes page erase. Benefitting from the ARM Cortex-M0 Thumb instruction set, the LPC1200 has up to 50% higher code density compared to common 8/16-bit MCUs performing typical tasks. The LPC1200 also features an optimized ROM-based divide library for Cortex-M0, which offers code size saving and several times the arithmetic performance of software based libraries. The high efficiency of the Cortex-M0 core also helps the LPC1200 achieve lower average power for similar applications. The LPC1200 has up to 55 GPIO and new onboard peripherals including DMA, CRC, comparators, an RTC, and a 1% internal oscillator, which provides the accuracy needed for Baud rate generation.

Development tools

The easy-to-use LPCXpresso IDE for the LPC1200 series is priced under \$30. Other development tools from IAR, Keil, Hitex, and Code Red can be found at www.nxp.com/microcontrollers. All NXP's Cortex-M microcontrollers are upwardly binary compatible and offer all the advantages of a single development toolchain. Users can easily migrate their designs between Cortex-M0 and Cortex-M3 with minimum effort.

Additional features

- ▶ Programmable high-current output driver on four pins
- ▶ Processor wake-up from Deep-sleep mode via 12 port pins or peripherals interrupts
- ▶ Power-On Reset (POR)
- ▶ Brownout detect with four separate thresholds for interrupt and forced reset
- ▶ 12 MHz internal RC oscillator trimmed to 1% accuracy that can also be used as a system clock or Baud rate generator
- ▶ PLL allows CPU operation up to the maximum CPU rate without the need for a high-frequency crystal. Can be run from the main oscillator, the internal RC oscillator, or the Watchdog oscillator
- ▶ Clock generation unit with divider that can reflect the main oscillator clock, IRC clock, CPU clock, and Watchdog clock.
- ▶ Available in 48- or 64-pin LQFP package

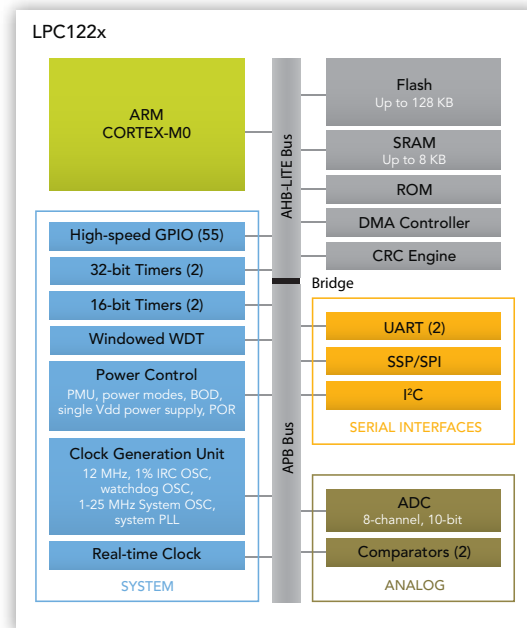

Selection guide

Type	f _{max} (MHz)	FLASH (KB)	RAM (KB)	I/O pins	DMA	CRC	RS-485	UART	I ² C/FM+	SPI	ADC
LPC1227FBD64/301	30	128	8	55	1	1	1	2	1	1	1
LPC1226FBD64/301	30	96	8	55	1	1	1	2	1	1	1
LPC1225FBD64/321	30	80	8	55	1	1	1	2	1	1	1
LPC1225FBD64/301	30	64	8	55	1	1	1	2	1	1	1
LPC1224FBD64/121	30	48	4	55	1	1	1	2	1	1	1
LPC1224FBD64/101	30	32	4	55	1	1	1	2	1	1	1
LPC1227FBD48/301	30	128	8	39	1	1	1	2	1	1	1
LPC1226FBD48/301	30	96	8	39	1	1	1	2	1	1	1
LPC1225FBD48/321	30	80	8	39	1	1	1	2	1	1	1
LPC1225FBD48/301	30	64	8	39	1	1	1	2	1	1	1
LPC1224FBD48/121	30	48	4	39	1	1	1	2	1	1	1
LPC1224FBD48/101	30	32	4	39	1	1	1	2	1	1	1

www.nxp.com

© 2011 NXP Semiconductors N.V.

All rights reserved. Reproduction in whole or in part is prohibited without the prior written consent of the copyright owner. The information presented in this document does not form part of any quotation or contract, is believed to be accurate and reliable and may be changed without notice. No liability will be accepted by the publisher for any consequence of its use. Publication thereof does not convey nor imply any license under patent- or other industrial or intellectual property rights.

Date of release: February 2011

Document order number: 9397 750 17026

Printed in the Netherlands