

2.50mm (0.098") PITCH CONNECTOR

Wire-to-Wire
Plug

25045HP Series

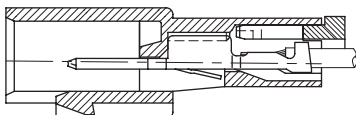
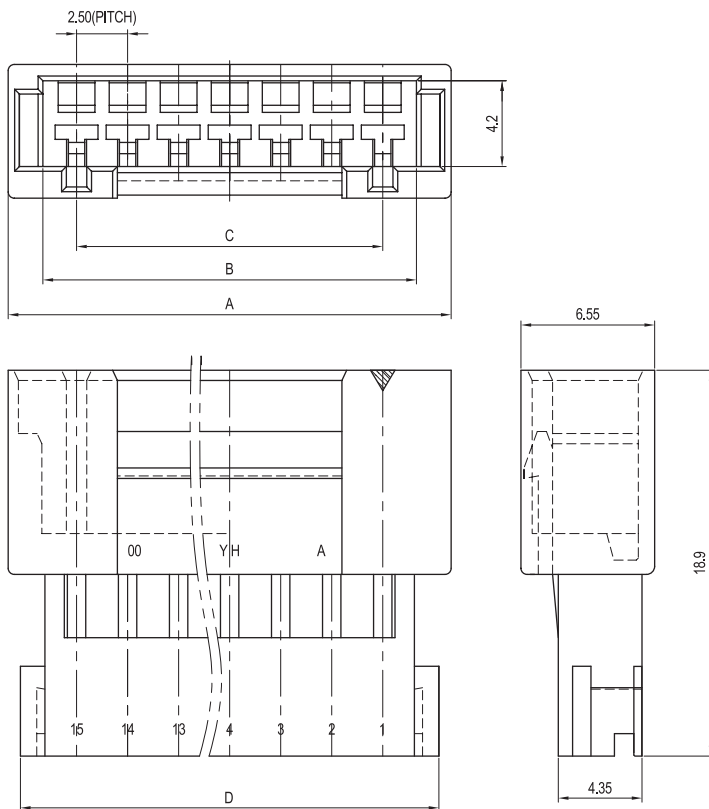
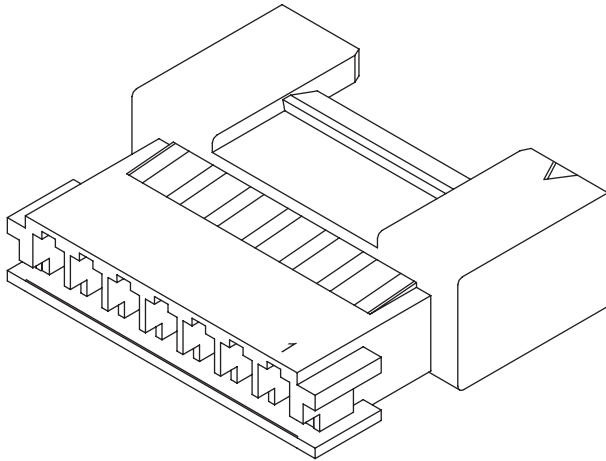

TERMINAL ASSEMBLY DRAWING

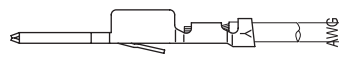

AWG : #22 ~ #28

Material

I/NO	DESCRIPTION	TITLE	MATERIAL
1	PLUG	25045HP	PA66, UL94 V Grade

Available Pin

PARTS NO.	A	B	C	D
25045HP-02000	9.2	5.8	2.5	8.0
25045HP-03000	11.7	8.3	5.0	10.5
25045HP-04000	14.2	10.8	7.5	13.0
25045HP-05000	16.7	13.3	10.0	15.5
25045HP-06000	19.2	15.8	12.5	18.0
25045HP-07000	21.7	18.3	15.0	20.5
25045HP-08000	24.2	20.8	17.5	23.0
25045HP-09000	26.7	23.3	20.0	25.5
25045HP-10000	29.2	25.8	22.5	28.0
25045HP-11000	31.7	28.3	25.0	30.5
25045HP-12000	34.2	30.8	27.5	33.0
25045HP-13000	36.7	33.3	30.0	35.5
25045HP-14000	39.2	35.8	32.5	38.0
25045HP-15000	41.7	38.3	35.0	40.5

Specification

ITEM	SPEC
Voltage Rating	AC/DC 250V
Current Rating	AC/DC 2A
Operating Temperature	-25°C~+85°C
Contact Resistance	30mΩ MAX
Withstanding Voltage	AC1000V/1min
Insulation Resistance	1000MΩ MIN
Applicable Wire	AWG #22~#28
Applicable P.C.B	1.2~1.6mm
Applicable FPC/FFC	-
Solder Height	-
Crimp Tensile Strength	-
UL FILE NO	-

Application Terminal : 25045TP, 25048TP