

规格书编号

SPEC NO :

产品规格书

SPECIFICATION

CUSTOMER 客户: _____
PRODUCT 产品: **SAW FILTER**
MODEL NO 型号: **HD F4521**
PREPARED 编制: _____ CHECKED 审核: **Houshihong**
APPROVED 批准: **CHARLES** DATE 日期: **2007-01-25**

客户确认 CUSTOMER RECEIVED:		
审核 CHECKED	批准 APPROVED	日期 DATE

无锡市好达电子有限公司
Shoulder Electronics Limited

1.Features

- _ RF bandpass filter
- _ High attenuation
- _ Usable bandwidth 5MHz
- _ No matching 50Ω single-ended operation
- _ Ceramic Surface Mounted Device (SMD) Package

2. ELECTRICAL SPECIFICATION

Parameter	Rating	Unit
Operating Temperature Range	-30~85	°C
Storage Temperature Range	-40~85	°C
DC Voltage VDC	10	V
Power Handling Capability	30	dBm

Electronic Characteristics

2-1. Typical frequency response

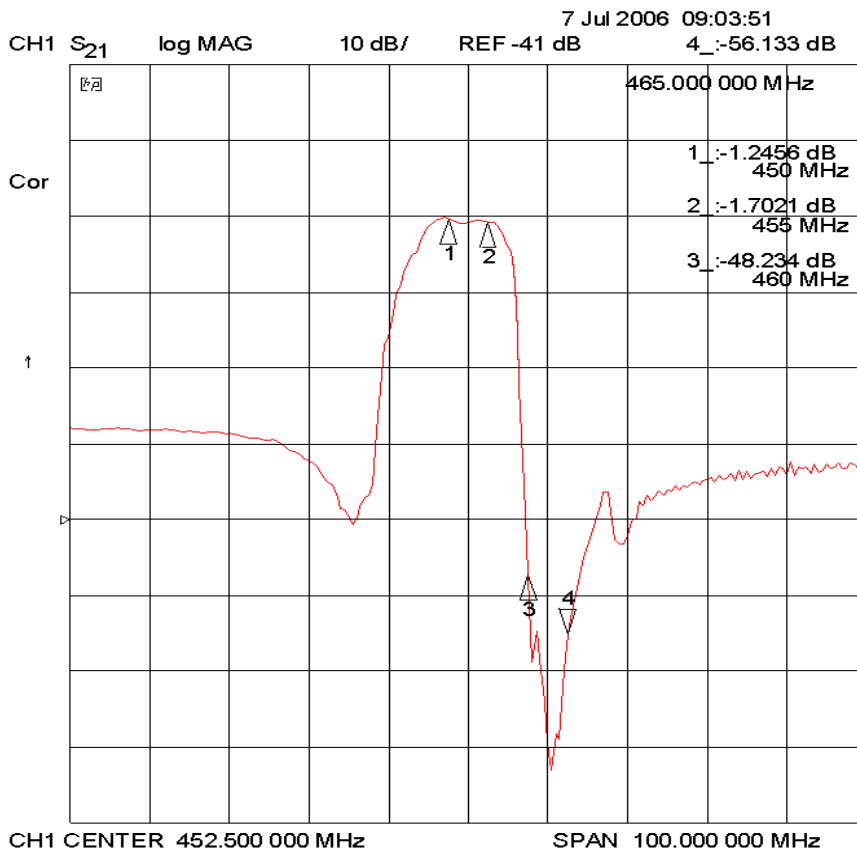

2-2 Input / Output VSWR Charts

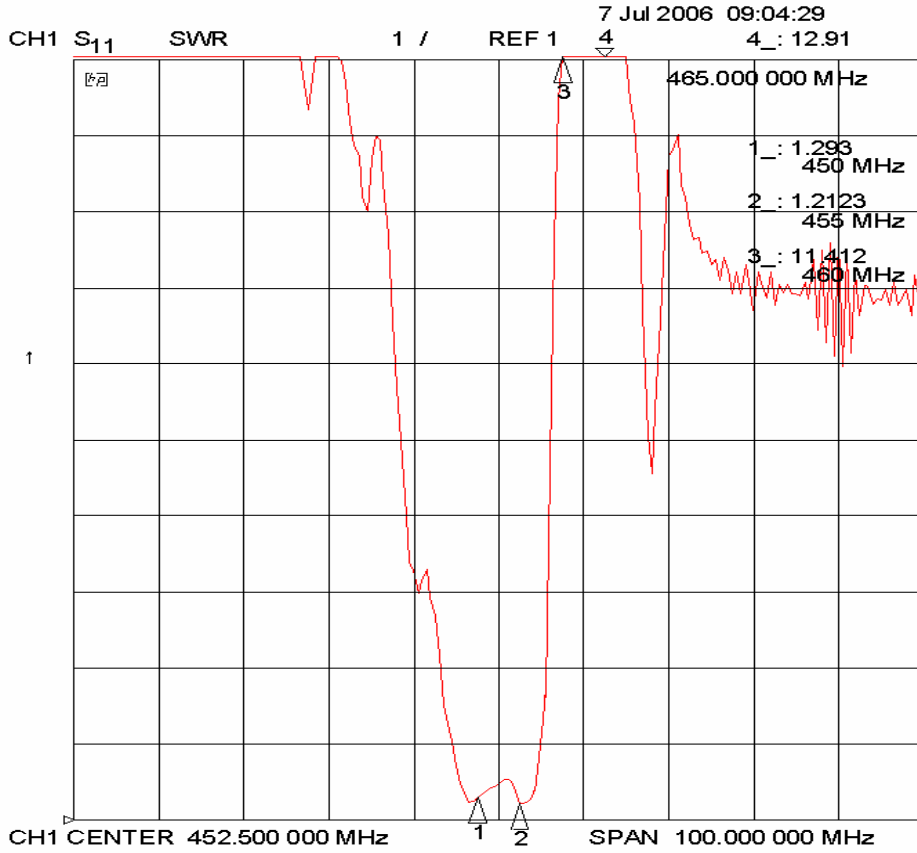

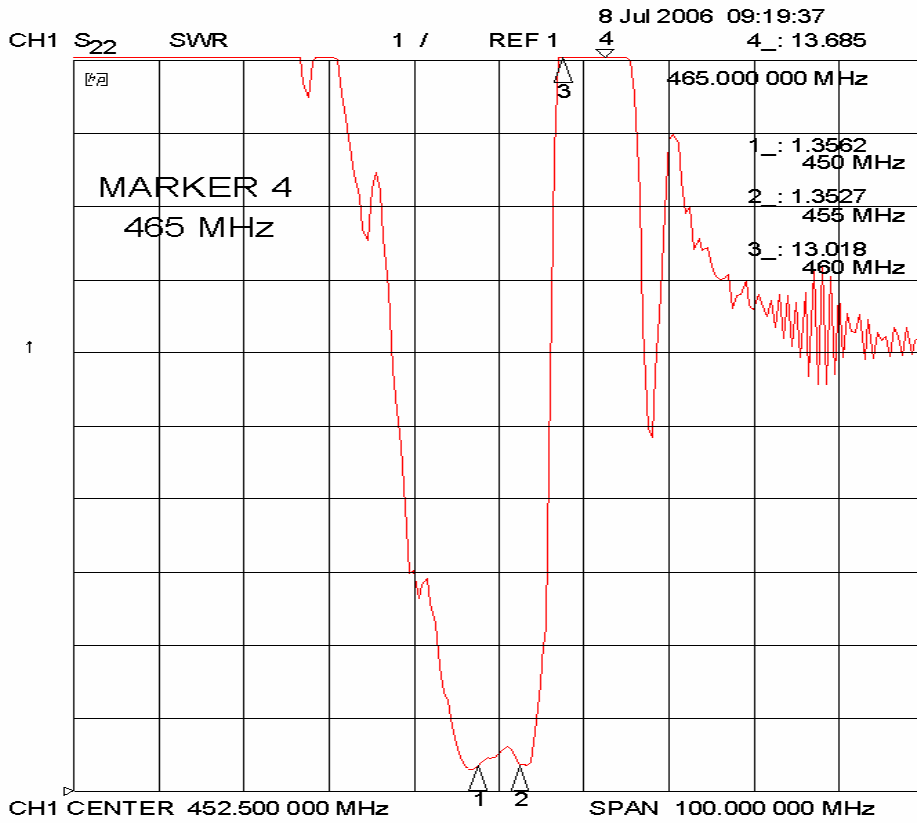

2-3Input / Output Smith Charts

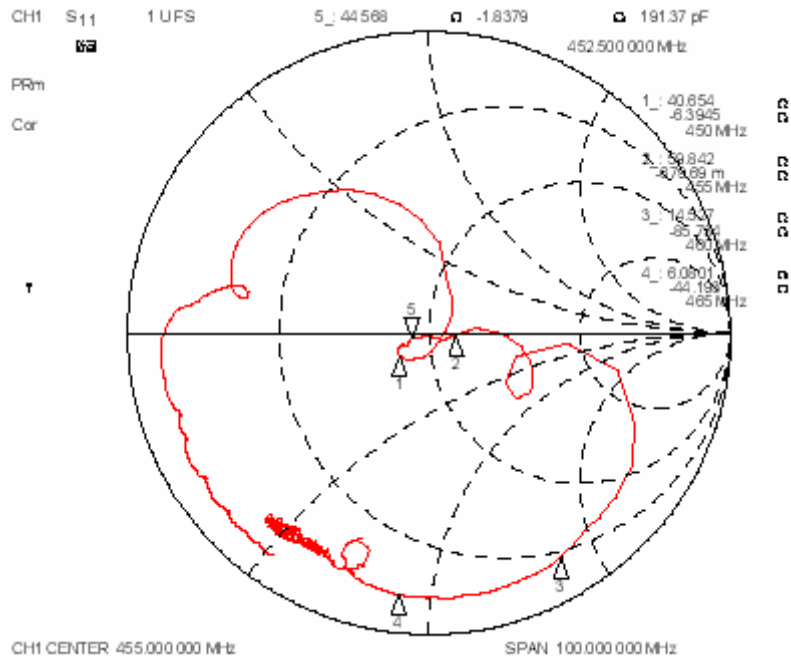

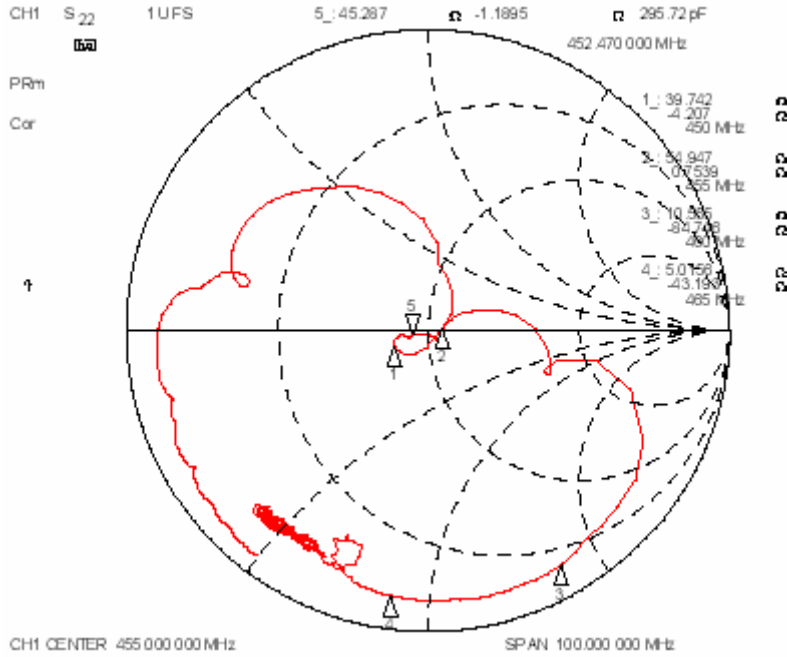

2-4.Electrical characteristics

		Minimum	Typical	Maximum
Center Frequency (F0)	MHz	-	452.5	-
Insertion Loss (F0 +/- 2.5 MHz)	dB	-	2.0	2.5
Amplitude Ripple (F0 +/- 2.5 MHz)	dB	-	0.8	1.2
VSWR (F0 +/- 2.5 MHz)		-	1.5	2.0
Relative Attenuation				-
0.3 MHz ~ 347.5 MHz		30	35	
347.5 MHz ~ 442.5 MHz	dB	25	30	
460.0 MHz ~ 465.0 MHz		40	43	
465.0 MHz ~ 1700 MHz		30	32	
1700 MHz ~ 3000 MHz		25	30	
Input/Output Impedance	Ω	-	50	-
Temperature Coefficient of Frequency	ppm/°C	-	-32	-

3. TEST CIRCUIT

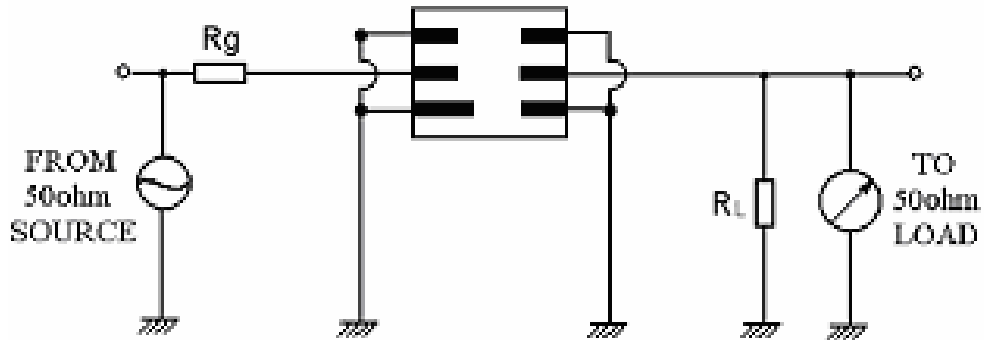

4-1. DIMENSION

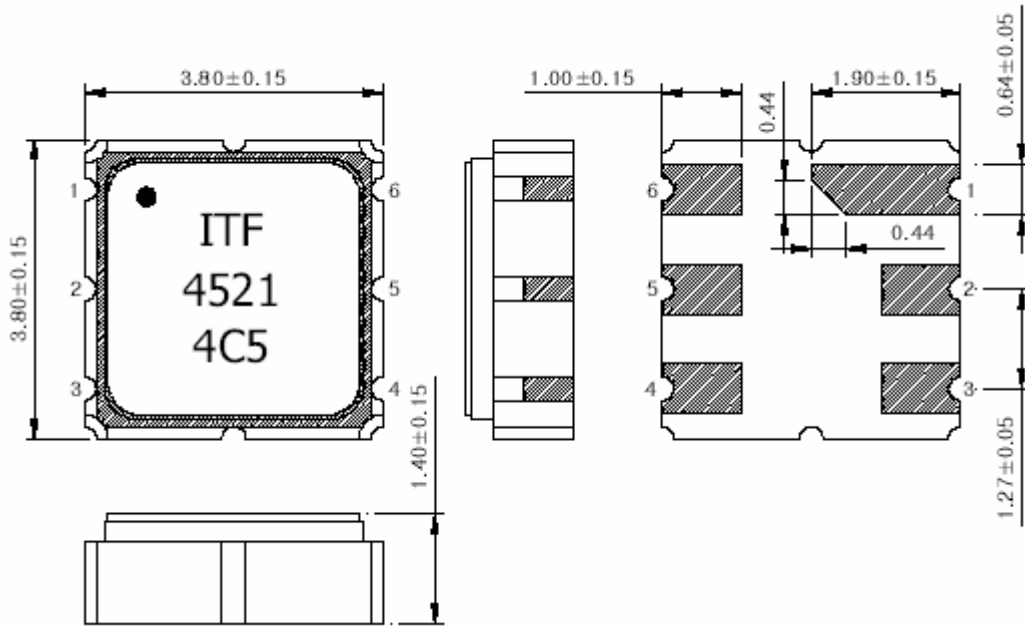

Pin Configuration	
2	Input
5	Output
1, 3, 4, 6	Case ground

4-2 Marking Configuration

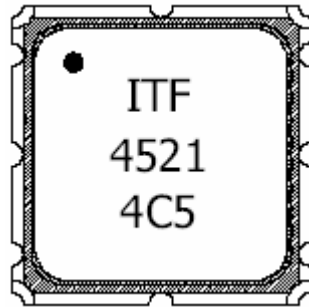

1)

ITF²⁾

4521³⁾

4C5⁴⁾

1) Pad Number 1 Index

2) Manufacturer name

3) Marking Number

4) Lot Number

4-3 picture

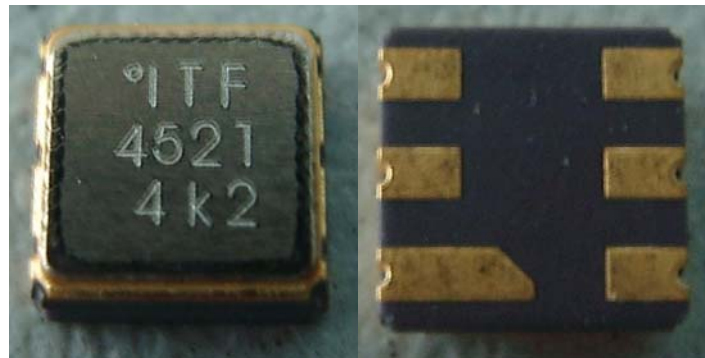

5.Environmental Performance Characteristics

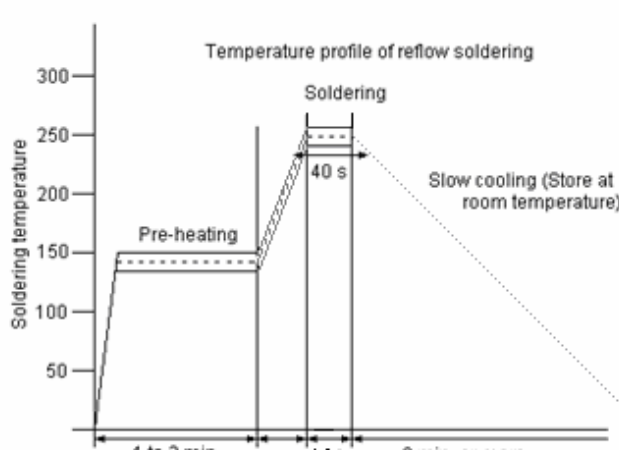
Item	Condition	Specifications																					
High temperature	The specimen shall be store at a temperature of 85±2℃ for 96±4h. Then it shall be subjected to standard atmospheric conditions for 1h, after which measurement shall be made within 1h.	Mechanical characteristics and specifications in electrical characteristics shall be satisfied. There shall be no excessive change in appearance.																					
Low temperature	The specimen shall be store at a temperature of -30±3℃ for 96±4h. Then it shall be subjected to standard atmospheric conditions for 1h, after which measurement shall be made within 1h.																						
Humidity	The specimen shall be store at a temperature of 40±2℃ with relative humidity of 90% to 96% for 96±4h. Then it shall be subjected to standard atmospheric conditions for 1h, after which measurement shall be made within 1h.																						
Thermal shock	The specimen shall be subjected to 8 continuous cycles each as shown below. Then it shall be subjected to standard atmospheric conditions for 1h, after which measurement shall be made within 1h.																						
	<table border="1"> <thead> <tr> <th></th> <th>Temperature</th> <th>Duration</th> </tr> </thead> <tbody> <tr> <td>1</td> <td>+25℃=>-40℃</td> <td>0.5h</td> </tr> <tr> <td>2</td> <td>-40℃</td> <td>4h</td> </tr> <tr> <td>3</td> <td>-40℃=>+85℃</td> <td>2h</td> </tr> <tr> <td>4</td> <td>+85℃</td> <td>4h</td> </tr> <tr> <td>5</td> <td>+85℃=>+25℃</td> <td>0.5h</td> </tr> <tr> <td>6</td> <td>+25℃</td> <td>1h</td> </tr> </tbody> </table>			Temperature	Duration	1	+25℃=>-40℃	0.5h	2	-40℃	4h	3	-40℃=>+85℃	2h	4	+85℃	4h	5	+85℃=>+25℃	0.5h	6	+25℃	1h
	Temperature		Duration																				
1	+25℃=>-40℃	0.5h																					
2	-40℃	4h																					
3	-40℃=>+85℃	2h																					
4	+85℃	4h																					
5	+85℃=>+25℃	0.5h																					
6	+25℃	1h																					
Resistance to Soldering heat	<p>Reflow soldering method Peak: 255 ±5 ℃, 220 ±5℃, 40s At electrode temperature of the specimen.</p>  <p>The graph shows the temperature profile of reflow soldering. The y-axis is 'Soldering temperature' ranging from 0 to 300. The x-axis shows time intervals: '1 to 2 min.' for pre-heating, '10s' for soldering, and '2 min. or more' for slow cooling. The temperature rises to 150°C during pre-heating, then to 255°C during soldering, and finally cools down slowly to room temperature.</p>																						

	<p>The specimen shall be passed through the reflow furnace with the condition shown in the above profile for 1 time.</p> <p>The specimen shall be stored at standard atmospheric conditions for 1h, after which the measurement shall be made. Test board shall be 1.6 mm thick. Base material shall be glass fabric base epoxy resin.</p>	
Solder ability	Immerse the pins melt solder at 260°C+5/-0°C for 5 sec.	More then 95% of total area of the pins should be covered with solder

6.Mechanical Test

Items	Conditions	Specifications
Vibration	600-3300rpm amplitude 1.5mm 3 directions 2 H each	There shall be no damage.
Drop	On maple plate from 1m high 3 times	
Lead pull	Pull with 1kg force for 30 seconds	
Lead bend	90° bending with 500g weigh 2 times	

7. REMARK

7.1 Static voltage

Static voltage between signal load & ground may cause deterioration & destruction of the component. Please avoid static voltage.

7.2 Ultrasonic cleaning

Ultrasonic vibration may cause deterioration & destruction of the component. Please avoid ultrasonic cleaning

7.3 Soldering

Only leads of component may be soldered. Please avoid soldering another part of component.

8. Packing

8.1 Dimensions

- (1) Carrier Tape: Figure 1
- (2) Reel: Figure 2
- (3) The product shall be packed properly not to be damaged during transportation and storage.

8.2 Reeling Quantity

- 1000 pcs/reel 7"
- 3000 pcs/reel 13"

8.3 Taping Structure

- (1) The tape shall be wound around the reel in the direction shown below.

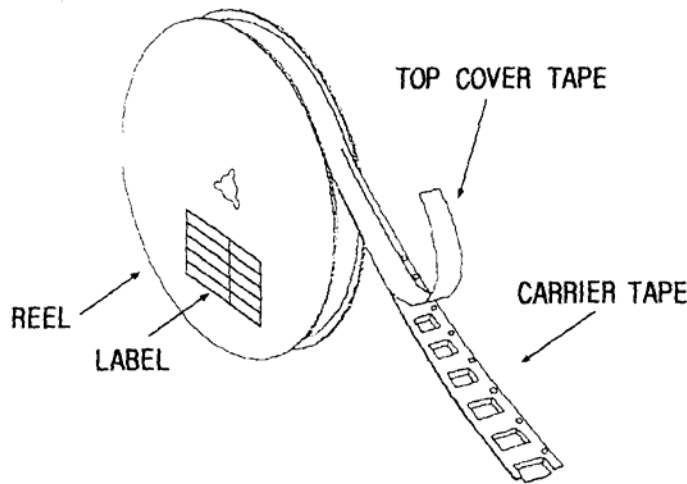

- (2) Label

Device Name	
User Product Name	
Quantity	
Lot No.	

- (3) Leader part and vacant position specifications.

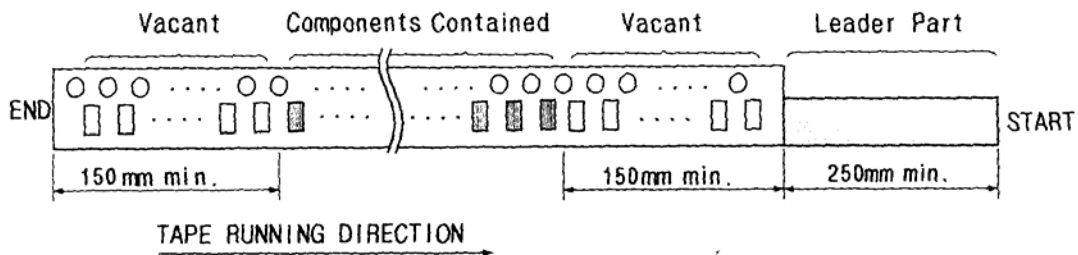

9. TAPE SPECIFICATIONS

9.1 Tensile Strength of Carrier Tape: 4.4N/mm width

9.2 Top Cover Tape Adhesion (See the below figure)

- (1) pull off angle: 0~15°
- (2) speed: 300mm/min.
- (3) force: 20~70g

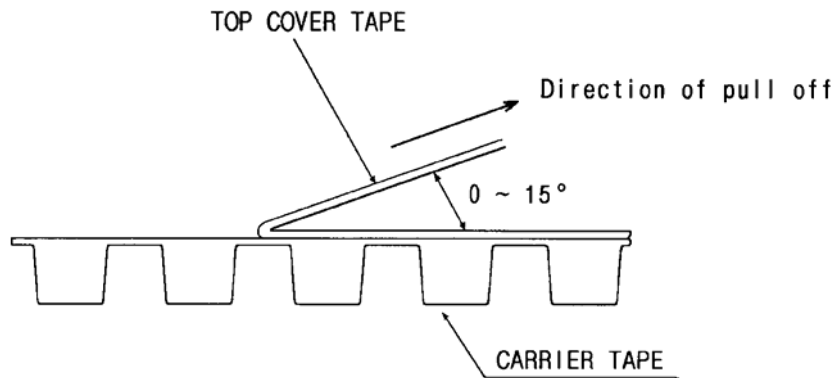

[Figure 1] Carrier Tape Dimensions

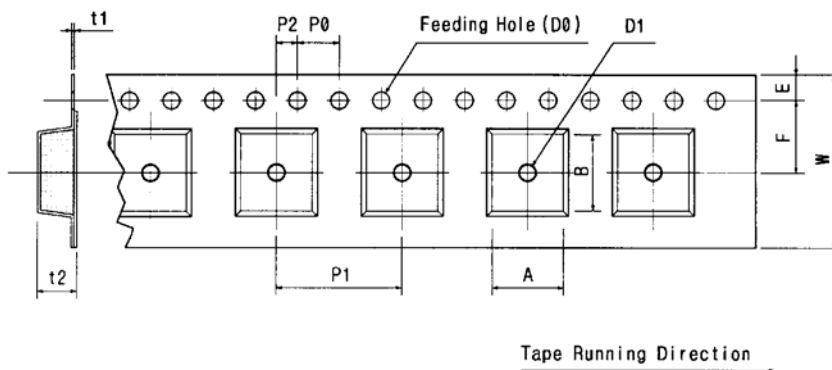

[Unit:mm]

W	F	E	P0	P1	P2	D0	D1	t1	t2	A	B
12.00	5.50	1.75	4.00	8.00	2.00	Ø1.50	Ø1.0	0.25	1.65	4.04	4.10
±0.30	±0.10	±0.10	±0.10	±0.10	±0.10		±0.25	±0.05	±0.10	±0.10	±0.10

[Figure 2]

[Unit:mm]

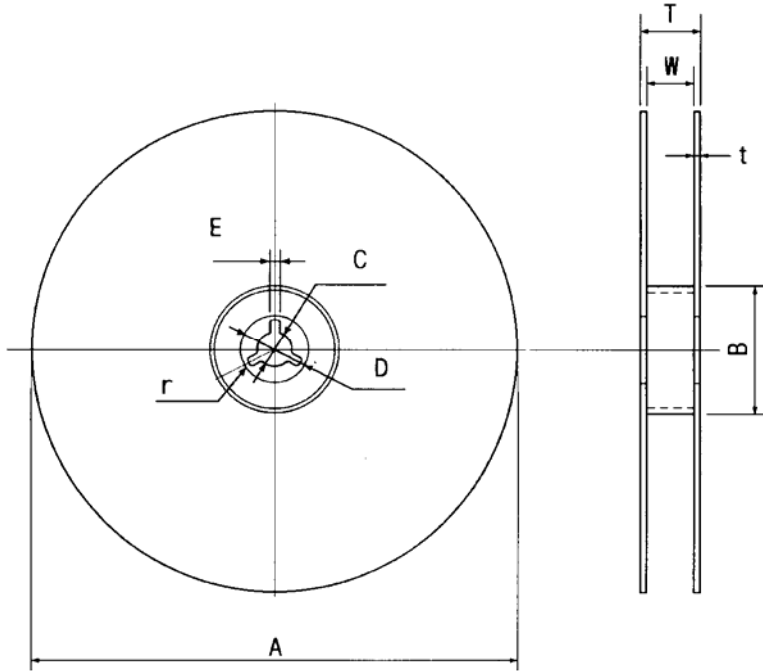

A	B	C	D	E	W	t	r
Ø330	Ø100	Ø13	Ø21	2	13	3	1.0
±1.0	±0.5	±0.5	±0.8	±0.5	±0.3	max.	max.

10.REVIRION

Date	Page	Revision	Reason
2005-6-15		A	NEW
2006-5-16		B	Customer's require
2006-5-25		C	Customer's require
2006-7-7		D	Customer's require