

TOSHIBA MOS MEMORY PRODUCTS

F-46-23-14

TC55257APL-85/APL-10/APL-12 TC55257AFL-85/AFL-10/AFL-12

DESCRIPTION

The TC55257APL is 262,144 bit static random access memory organized as 32,768 words by 8 bits using CMOS technology, and operated from a single 5V supply. Advanced circuit techniques provide both high speed and low power features with a operating current of 5mA/MHz (Typ.) and minimum cycle time of 85ns. When \overline{CE} is a logical high, the device is placed in low power standby mode in which standby current is 2 μ A typically. The TC55257APL has two control inputs. Chip enable (\overline{CE}) allow for device selection and data retention control, and an output enable input (\overline{OE}) provides fast memory access. Thus the TC55257APL is suitable for use in various microprocessor application systems where high speed, low power, and battery back up are required. The TC55257APL is offered in both a standard dual-in-line 28 pin plastic package (0.6 inch width) and small-out-line plastic flat package.

FEATURES

- Low Power Dissipation
27.5mW/MHz (Typ.) Operating
- Standby Current
100 μ A (Max.):
TC55257APL-85/AFL-85
APL-10/AFL-10
APL-12/AFL-12
- 5V Single Power Supply
- Power Down Feature: \overline{CE}

- Data Retention Supply Voltage: 2.0~5.5V
- Access Time

	TC55257APL-85 TC55257AFL-85	TC55257APL-10 TC55257AFL-10	TC55257APL-12 TC55257AFL-12
Access Time (Max.)	85ns	100ns	120ns
Chip Enable Access Time (Max.)	85ns	100ns	120ns
Output Enable Time (Max.)	45ns	50ns	60ns

- Directly TTL Compatible: All Inputs and Outputs
- Plastic DIP and Plastic FP Package

PIN CONNECTION (TOP VIEW)

A14	1	28	V _{DD}
A12	2	27	R/W
A7	3	26	A13
A6	4	25	A8
A5	5	24	A9
A4	6	23	A11
A3	7	22	\overline{OE}
A2	8	21	A10
A1	9	20	\overline{CE}
A0	10	19	I/O8
I/O1	11	18	I/O7
I/O2	12	17	I/O6
I/O3	13	16	I/O5
GND	14	15	I/O4

PIN NAMES

A0 ~ A14	Address Inputs
R/W	Read/Write Control Input
\overline{OE}	Output Enable Input
\overline{CE}	Chip Enable Input
I/O1 ~ I/O8	Data Input/Output
V _{DD}	Power (+5V)
GND	Ground

BLOCK DIAGRAM

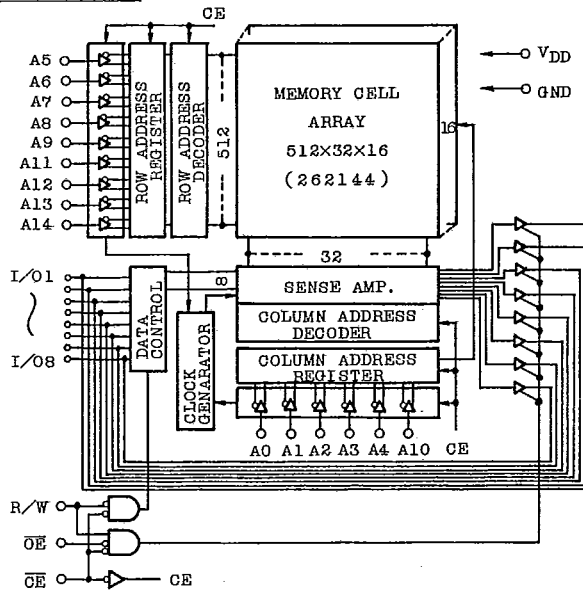

TC55257APL-85/APL-10/APL-12
TC55257AFL-85/AFL-10/AFL-12

T-46-23-14

OPERATION MODE

OPERATION MODE	\overline{CE}	\overline{OE}	R/W	I/O1 ~ I/O8	POWER
Read	L	L	H	D _{OUT}	I _{DDO}
Write	L	*	L	D _{IN}	I _{DDO}
Output Deselect	L	H	H	High-Z	I _{DDO}
Stndby	H	*	*	High-Z	I _{DDS}

*) H or L

MAXIMUM RATINGS

SYMBOL	ITEM	RATING	UNIT
V _{DD}	Power Supply Voltage	-0.3 ~ 7.0	V
V _{IN}	Input Voltage	-0.3* ~ 7.0	V
V _{I/O}	Input and Output Voltage	-0.5 ~ V _{DD} +0.5	V
P _D	Power Dissipation	1.0	W
T _{solder}	Soldering Temperature	260 • 10	°C • sec
T _{strg}	Storage Temperature	-55 ~ 150	°C
T _{opr}	Operating Temperature	0 ~ 70	°C

*) -3.0V at pulse width 50ns

D.C. RECOMMENDED OPERATING CONDITIONS

SYMBOL	PARAMETER	MIN.	TYP.	MAX.	UNIT
V _{DD}	Power Supply Voltage	4.5	5.0	5.5	V
V _{IH}	Input High Voltage	2.2	-	V _{DD} +0.3	V
V _{IL}	Input Low Voltage	-0.3*	-	0.8	V
V _{DH}	Data Retention Supply Voltage	2.0	-	5.5	V

*) -3.0V at pulse width 50ns

D.C. and OPERATING CHARACTERISTICS (Ta=0~70°C, VDD=5V±10%)

SYMBOL	PARAMETER	TEST CONDITION	MIN.	TYP.	MAX.	UNIT	
IIL	Input Leakage Current	V _{IN} =0 ~ V _{DD}	-	-	±1.0	μA	
IOH	Output High Current	V _{OH} =2.4V	-1.0	-	-	mA	
IOL	Output Low Current	V _{OL} =0.4V	4.0	-	-	mA	
ILO	Output Leakage Current	$\overline{CE}=V_{IH}$ or R/W=V _{IL} or $\overline{OE}=V_{IH}$ V _{OUT} =0 ~ V _{DD}	-	-	±1.0	μA	
I _{DDO1}	Operating Current	V _{DD} =5.5V $\overline{CE}=V_{IL}$, R/W=V _{IH} Other Input =V _{IH} /V _{IL} I _{OUT} =0mA	t _{cycle} =1μs	-	10	-	mA
			t _{cycle} = Min. cycle	-	-	70	
I _{DDO2}	Operating Current	V _{DD} =5.5V $\overline{CE}=0.2V$, R/W=V _{DD} -0.2V Other Input =V _{DD} -0.2V/0.2V I _{OUT} =0mA	t _{cycle} =1μs	-	5	-	mA
			t _{cycle} = Min. cycle	-	-	60	
I _{DDS1}	Standby Current	$\overline{CE}=V_{IH}$	-	-	3	mA	
I _{DDS2}	Standby Current	$\overline{CE}=V_{DD}-0.2V$ V _{DD} =2.0 ~ 5.5V	-	2	100	μA	

CAPACITANCE (Ta=25°C, f=1MHz)

SYMBOL	PARAMETER	TEST CONDITION	MAX.	UNIT
C _{IN}	Input Capacitance	V _{IN} =GND	10	pF
C _{OUT}	Output Capacitance	V _{OUT} =GND	10	pF

Note: This parameter periodically sampled is not 100% tested.

TC55257APL-85/APL-10/APL-12
TC55257AFL-85/AFL-10/AFL-12

T-46-23-14

A.C. CHARACTERISTICS (Ta=0~70°C, VDD=5V±10%)

READ CYCLE

SYMBOL	PARAMETER	TC55257APL-85 TC55257AFL-85		TC55257APL-10 TC55257AFL-10		TC55257APL-12 TC55257AFL-12		UNIT
		MIN.	MAX.	MIN.	MAX.	MIN.	MAX.	
t _{RC}	Read Cycle Time	85	-	100	-	120	-	ns
t _{ACC}	Address Access Time	-	85	-	100	-	120	
t _{CO}	CE Access Time	-	85	-	100	-	120	
t _{OE}	Output Enable to Output in Valid	-	45	-	50	-	60	
t _{COE}	Chip Enable (CE) to Output in Low-Z	10	-	10	-	10	-	
t _{OOE}	Output Enable to Output in Low-Z	5	-	5	-	5	-	
t _{OD}	Chip Enable (CE) to Output in High-Z	-	30	-	50	-	60	
t _{ODO}	Output Enable to Output in High-Z	-	30	-	40	-	50	
t _{OH}	Output Data Hold Time	5	-	10	-	10	-	

WRITE CYCLE

SYMBOL	PARAMETER	TC55257APL-85 TC55257AFL-85		TC55257APL-10 TC55257AFL-10		TC55257APL-12 TC55257AFL-12		UNIT
		MIN.	MAX.	MIN.	MAX.	MIN.	MAX.	
t _{WC}	Write Cycle Time	85	-	100	-	120	-	ns
t _{WP}	Write Pulse Width	60	-	70	-	80	-	
t _{CW}	Chip Selection to End of Write	65	-	90	-	100	-	
t _{AS}	Address Set up Time	0	-	0	-	0	-	
t _{WR}	Write Recovery Time	5	-	5	-	5	-	
t _{ODW}	R/W to Output High-Z	-	30	-	50	-	60	
t _{OEW}	R/W to Output Low-Z	10	-	10	-	10	-	
t _{DS}	Data Set up Time	40	-	40	-	50	-	
t _{DH}	Data Hold Time	0	-	0	-	0	-	

A.C. TEST CONDITIONS

Output Load : 100pF + 1 TTL Gate
 Input Pulse Level : 0.6V, 2.4V
 Timing Measurement: 0.8V, 2.2V
 Reference Level : 0.8V, 2.2V
 t_r, t_f : 5ns

WRITE CYCLE 2 (4) (\overline{CE} Controlled Write)

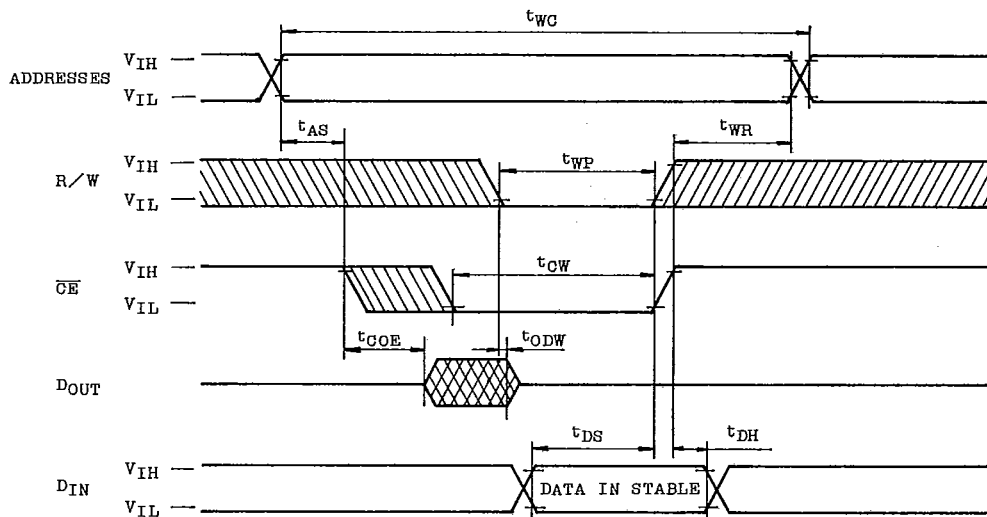

- Note: 1. R/W is High for Read Cycle.
2. Assuming that \overline{CE} low transition occurs coincident with or after R/W Low transition, Outputs remain in a high impedance state.
3. Assuming that \overline{CE} High transition occurs coincident with or prior to R/W High transition, Outputs remain in a high impedance state.
4. Assuming that \overline{OE} is High for Write Cycle, Outputs are in high impedance state during this period.

DATA RETENTION CHARACTERISTICS (Ta=0~70°C)

SYMBOL	PARAMETER	MIN.	TYP.	MAX.	UNIT	
V _{DH}	Data Retention Supply Voltage	2.0	-	5.5	V	
I _{DDS2}	Standby Supply Current	V _{DH} =3.0V	-	-	50	μA
		V _{DH} =5.5V	-	-	100	
t _{CDR}	Chip Deselection to Data Retention Mode	0	-	-	μs	
t _R	Recovery Time	t _{RC(1)}	-	-		

Note (1): Read Cycle Time.

\overline{CE} Controlled Data Retention Mode

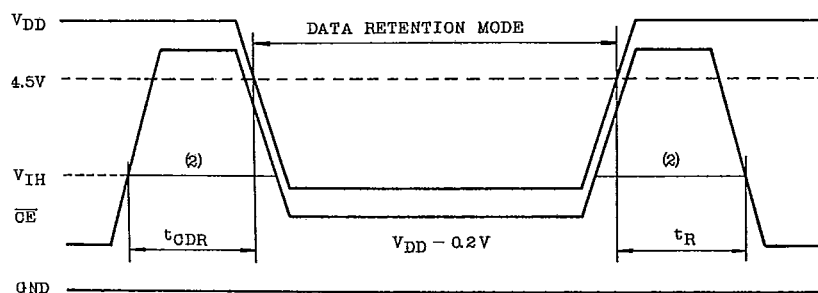

Note (2): If the V_{IH} of \overline{CE} is 2.2V in operation, I_{DDS1} current flows during the period that the V_{DD} voltage is going down from 4.5V to 2.4V.

TC55257APL-85/APL-10/APL-12
TC55257AFL-85/AFL-10/AFL-12

T-46-23-14

DIP 28 PIN OUTLINE DRAWING (6D28A-P)

Unit in mm

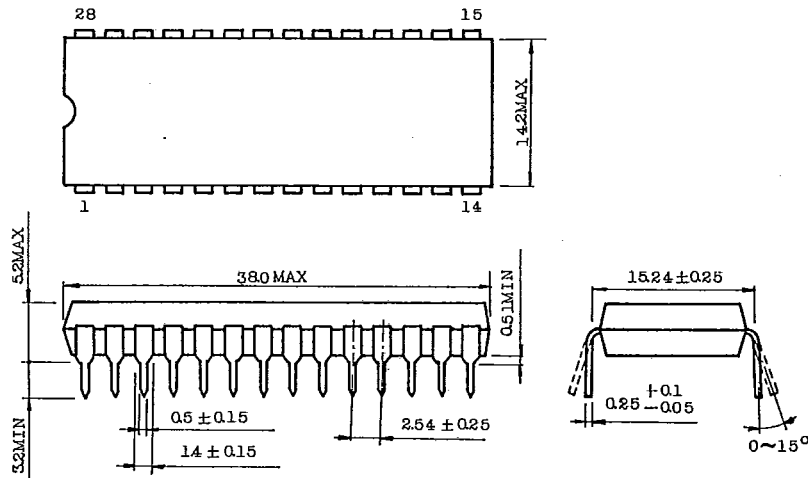

Note: Lead pitch is 2.54 and tolerance is ±0.25 against theoretical center of each lead that is obtained on the basis of No.1 and No.28 leads.

MFP 28 PIN OUTLINE DRAWING (F28GA-P)

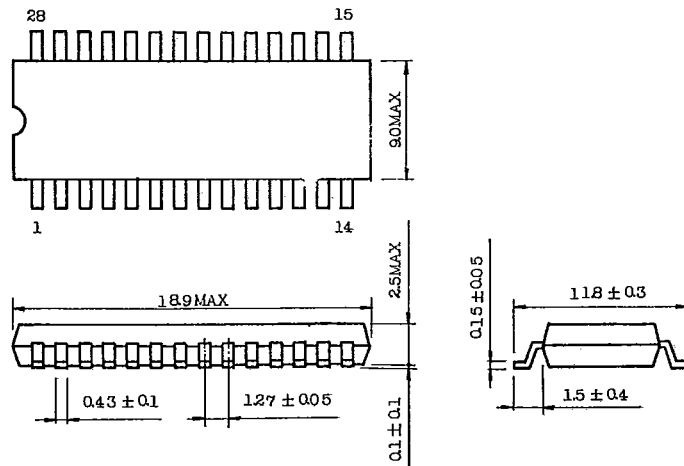

Note: Lead pitch is 1.27 and tolerance is ±0.12 against theoretical center of each lead that is obtained on the basis of No.1 and No.28 leads.