



## AUDIO PROCESSOR with Subwoofer Output

### ■ GENERAL DESCRIPTION

The **NJW1176** is a sound processor with subwoofer output includes all of functions processing audio signal for TV, such as tone control, balance, volume, mute, and AGC functions.

Also the **NJW1176** includes the LPF for subwoofer output and bass boost function.

The original surround system reproduces natural surround sound and clear vocal orientation.

All of internal status and variables are controlled by I<sup>2</sup>C BUS interface.

### ■ PACKAGE OUTLINE

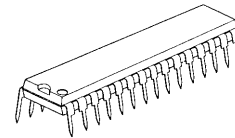
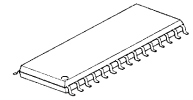

**NJW1176L**

**NJW1176M**

**NJW1176V**

### ■ FEATURES

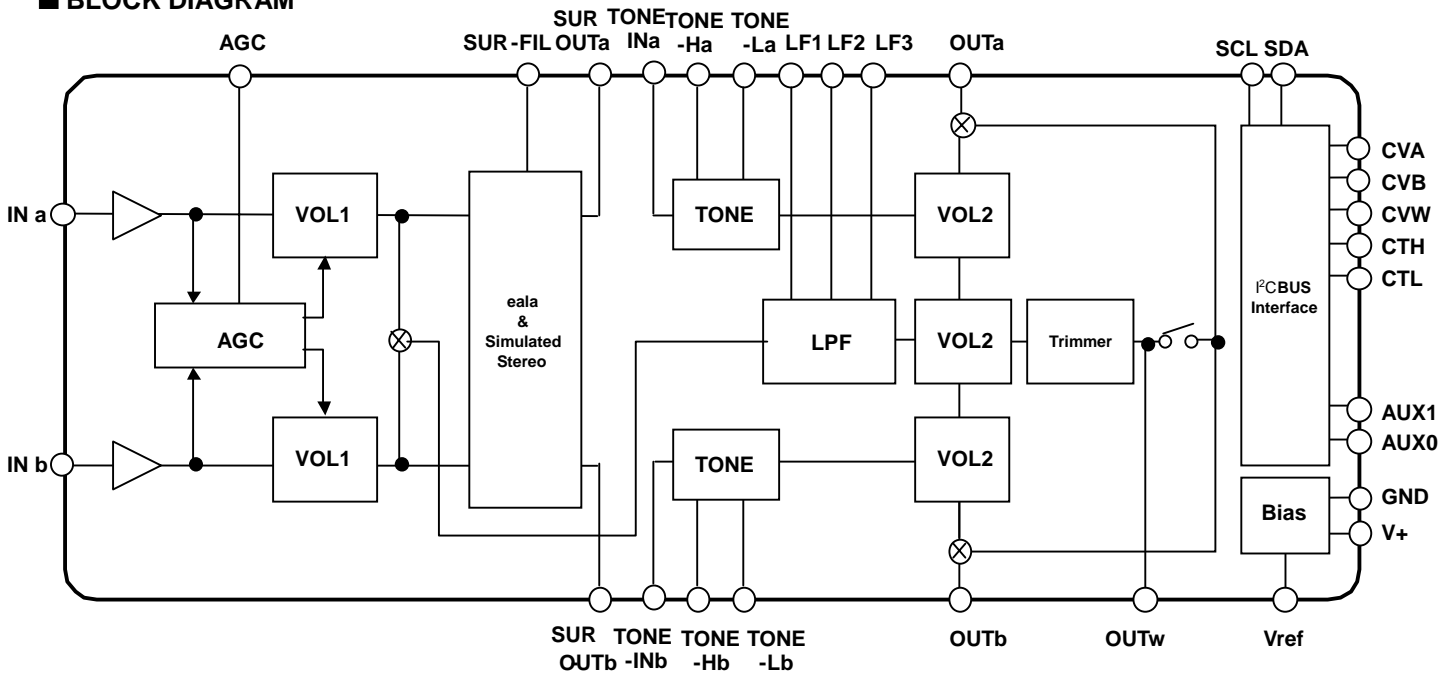
- Operating Voltage        7.5 to 13V
- 3ch Output (Lch, Rch, Subwoofer ch) / 2ch Output(Lch, Rch)
- LPF Filter (Adjustable cut off frequency by external parts)
- AGC Circuit (It reduces volume difference among input sources.)  
Adjustable AGC compression level by I<sup>2</sup>C BUS
- eala(NJRC Original Surround System)
- Simulated Stereo
- I<sup>2</sup>C BUS Interface
- Bi-CMOS Technology
- Package Outline        SDIP30, SDMP30, SSOP32

### ■ BLOCK DIAGRAM



## ■PIN CONFIGURATION (SDIP30, SDMP30)

1	INa	INb	30
2	CVW	LF2	29
3	LF1	LF3	28
4	SUR OUTa	SUR OUTb	27
5	TONE INa	TONE INb	26
6	TONE-Ha	TONE-Hb	25
7	TONE-La	TONE-Lb	24
8	OUTa	OUTb	23
9	AGC	OUTw	22
10	SUR-FIL	VREF	21
11	CVB	CTH	20
12	CVA	CTL	19
13	SDA	AUX0	18
14	SCL	AUX1	17
15	GND	Vcc	16

No.	Symbol	Function	No	Symbol	Function
1	INa	Ach Input	16	Vcc	Power Supply Pin
2	CVW	Wch DAC output terminal for LPF trimmer	17	AUX1	Auxiliary Output1
3	LF1	LPF filter1 terminal	18	AUX0	Auxiliary Output0
4	SUR OUTa	Ach Output for the Other Accessories	19	CTL	DAC Output for Tone Low Frequency
5	TONE INa	Ach Input From the Other Accessories	20	CTH	DAC Output for Tone High Frequency
6	TONE-Ha	Ach Treble Filter	21	VREF	Reference Voltage
7	TONE-La	Ach Bass Filter	22	OUTw	Wch Output
8	OUTa	Ach Output	23	OUTb	Bch Output
9	AGC	AGC Filter	24	TONE-Lb	Bch Bass Filter
10	SUR-FIL	eala and Simulated Stereo Filter	25	TONE-Hb	Bch Treble Filter
11	CVB	DAC Output for Bch Volume & Balance	26	TONE INb	Bch Input from the Other Accessories
12	CVA	DAC Output for Ach Volume & Balance	27	SUR OUTb	Bch Output for the Other Accessories
13	SDA	SDA Data Input (I <sup>2</sup> C BUS)	28	LF3	LPF filter3 terminal
14	SCL	SCL Data Input (I <sup>2</sup> C BUS)	29	LF2	LPF filter2terminal
15	GND	GND	30	INb	Bch Input

(\*) The AUX0 terminal should be connected via the protection resistance to 5V device.

## ■PIN CONFIGURATION (SSOP32)

1	INa	INb	32
2	CVW	LF2	31
3	LF1	LF3	30
4	SUR OUTa	SUR OUTb	29
5	TONE INa	TONE INb	28
6	TONE-Ha	TONE-Hb	27
7	TONE-La	TONE-Lb	26
8	OUTa	OUTb	25
9	AGC	OUTw	24
10	SUR-FIL	VREF	23
11	CVB	CTH	22
12	CVA	CTL	21
13	SDA	AUX0	20
14	SCL	AUX1	19
15	GND	Vcc	18
16	N.C.	N.C.	17

No.	Symbol	Function	No	Symbol	Function
1	INa	Ach Input	17	N.C.	No Connection
2	CVW	Wch DAC output terminal for LPF trimmer	18	Vcc	Power Supply Pin
3	LF1	LPF filter1 terminal	19	AUX1	Auxiliary Output1
4	SUR OUTa	Ach Output for the Other Accessories	20	AUX0	Auxiliary Output0
5	TONE INa	Ach Input From the Other Accessories	21	CTL	DAC Output for Tone Low Frequency
6	TONE-Ha	Ach Treble Filter	22	CTH	DAC Output for Tone High Frequency
7	TONE-La	Ach Bass Filter	23	VREF	Reference Voltage
8	OUTa	Ach Output	24	OUTw	Wch Output
9	AGC	AGC Filter	25	OUTb	Bch Output
10	SUR-FIL	eala and Simulated Stereo Filter	26	TONE-Lb	Bch Bass Filter
11	CVB	DAC Output for Bch Volume & Balance	27	TONE-Hb	Bch Treble Filter
12	CVA	DAC Output for Ach Volume & Balance	28	TONE INb	Bch Input from the Other Accessories
13	SDA	SDA Data Input (I <sup>2</sup> C BUS)	29	SUR OUTb	Bch Output for the Other Accessories
14	SCL	SCL Data Input (I <sup>2</sup> C BUS)	30	LF3	LPF filter3 terminal
15	GND	GND	31	LF2	LPF filter2terminal
16	N.C.	No Connection	32	INb	Bch Input

(\*) The AUX0 terminal should be connected via the protection resistance to 5V device.

## ■ ABSOLUTE MAXIMUM RATING (Ta=25°C)

PARAMETER	SYMBOL	RATING	UNIT
Supply Voltage	V <sup>+</sup>	15	V
Power Dissipation	P <sub>D</sub>	(L, M type) 700	mW
		(V type) 800 NOTE: EIA/JEDEC STANDARD Test board (76.2x114.3x1.6mm, 2layer, FR-4) mounting	
Operating Temperature Range	Topr	-20 to +75	°C
Storage Temperature Range	Tstg	-40 to +125	°C

## ■ ELECTRICAL CHARACTERISTICS

( Ta=25°C, V+=9V, Rg=600Ω, RL=47kΩ, Vin=100mVrms/1kHz unless otherwise specified)

PARAMETER	SYMBOL	Condition	Input			Output	MIN.	TYP.	MAX.	UNIT
			Input		Output					
			INa	INb						
Operating Voltage	V <sup>+</sup>		-	-	-	7.5	9.0	13.0	V	
Supply Current	I <sub>CC</sub>	No Signal	-	-	-	-	13	25	mA	
Reference Voltage	V <sub>REF</sub>	No Signal	-	-	-	4.0	4.5	5.0	V	
Maximum Input Voltage	V <sub>IM</sub>	VOL=-20dB, THD=1%	V <sub>in</sub>	-	OUTa	2.8	3.0	-	Vrms	
			-	V <sub>in</sub>	OUTb					
Maximum Output Voltage	V <sub>OM</sub>	VOL=0dB, THD=1%	V <sub>in</sub>	-	OUTa	-	2.5	-	Vrms	
			-	V <sub>in</sub>	OUTb					
Channel Balance	G <sub>CB</sub>	VOL=0dB	-	-	-	-1.5	0.0	1.5	dB	
Balance Boost A	BA <sub>BST</sub>	CHS="0", BAL="111111"	V <sub>in</sub>	V <sub>in</sub>	OUTa	-2.0	0.0	2.0	dB	
Balance Cut A	BA <sub>CUT</sub>	CHS="1", BAL="111111" Vin = 1Vrms	V <sub>in</sub>	V <sub>in</sub>	OUTa	-	-	-70	dB	
Balance Boost B	BB <sub>BST</sub>	CHS="1", BAL="111111"	V <sub>in</sub>	V <sub>in</sub>	OUTb	-2.0	0.0	2.0	dB	
Balance Cut B	BB <sub>CUT</sub>	CHS="0", BAL="111111" Vin = 1Vrms	V <sub>in</sub>	V <sub>in</sub>	OUTb	-	-	-70	dB	
Trimmer Boost	TR <sub>BST</sub>	VOL=0dB TRIM = +18dB	V <sub>in</sub>	V <sub>in</sub>	OUTw	16.0	18.0	20.0	dB	
Trimmer Cut	TR <sub>CUT</sub>	VOL=0dB TRIM = Mute	V <sub>in</sub>	V <sub>in</sub>	OUTw	-	-	-70	dB	
Total Harmonic Distortion	THD	Vo=0.5Vrms, BW=400Hz to 30kHz	V <sub>in</sub>	-	OUTa	-	-	0.5	%	
			-	V <sub>in</sub>	OUTb					
Maximum Gain	G <sub>VMAX</sub>	VOL=0dB	V <sub>in</sub>	-	OUTa	-2.0	0.0	2.0	dB	
			-	V <sub>in</sub>	OUTb					
Minimum Gain	G <sub>VMIN</sub>	VOL=MUTE Vin=1Vrms	V <sub>in</sub>	-	OUTa	-	-	-70	dB	
			-	V <sub>in</sub>	OUTb					
Channel Separation	CS	Vin=1Vrms A-weighted	V <sub>in</sub>	-	OUTb	-	-	-70	dB	
			-	V <sub>in</sub>	OUTa					
Output Noise 1	V <sub>NO1</sub>	VOL=0dB A-weighted	-	-	-	-	-90 (31.6)	-85 (56.2)	dBV (μVrms)	
Output Noise 2	V <sub>NO2</sub>	VOL=MUTE A-weighted	-	-	-	-	-106 (5.0)	-96 (15.8)	dBV (μVrms)	
Output Noise 3	V <sub>NO3</sub>	VOL=MUTE, TRIM=MUTE A-weighted	-	-	-	-	-100 (10.0)	-90 (30.0)	dBV (μVrms)	

BW : Band Width

## ■ ELECTRICAL CHARACTERISTICS

(Ta=25°C, V+=9V, Rg=600Ω, RL=47kΩ, Vin=100mVrms/1kHz unless otherwise specified)

PARAMETER	SYMBOL	Condition	Condition			MIN.	TYP.	MAX.	UNIT
			Input		Output				
			INa	INb					
<b>◆TONE</b>									
High Frequency Boost	HF <sub>BST</sub>	BCT="1" TREB=+15dB, f=10kHz	V <sub>in</sub>	-	OUTa	12.5	15.0	17.5	dB
			-	V <sub>in</sub>	OUTb				
High Frequency Flat	HF <sub>FLT</sub>	TREB=0, f=10kHz	V <sub>in</sub>	-	OUTa	-2.0	0.0	2.0	dB
			-	V <sub>in</sub>	OUTb				
High Frequency Cut	HF <sub>CUT</sub>	BCT="0" TREB=-15dB, f=10kHz	V <sub>in</sub>	-	OUTa	-17.5	-15.0	-12.5	dB
			-	V <sub>in</sub>	OUTb				
Low Frequency Boost	LF <sub>BST</sub>	BCB="1" BASS=+15dB, f=100Hz	V <sub>in</sub>	-	OUTa	12.5	15.0	17.5	dB
			-	V <sub>in</sub>	OUTb				
Low Frequency Flat	LF <sub>FLT</sub>	BASS=0, f=100Hz	V <sub>in</sub>	-	OUTa	-2.0	0.0	2.0	dB
			-	V <sub>in</sub>	OUTb				
Low Frequency Cut	LF <sub>CUT</sub>	BCB="0" BASS=-15dB, f=100Hz	V <sub>in</sub>	-	OUTa	-17.5	-15.0	-12.5	dB
			-	V <sub>in</sub>	OUTb				
<b>◆AGC</b>									
AGC Boost	AGC <sub>BST</sub>	Vin=50mVrms, f=1kHz AGC="1"	V <sub>in</sub>	-	OUTa	1.5	3.5	5.5	dB
			V <sub>in</sub>	V <sub>in</sub>	OUTb				
AGC Flat1	AGC <sub>FLT1</sub>	Vin=100mVrms, f=1kHz AGC="1", AGCL="00"	V <sub>in</sub>	V <sub>in</sub>	OUTa	-2.5	0.0	2.5	dB
			V <sub>in</sub>	V <sub>in</sub>	OUTb				
AGC Flat2	AGC <sub>FLT2</sub>	Vin=200mVrms, f=1kHz AGC="1", AGCL="01"	V <sub>in</sub>	V <sub>in</sub>	OUTa	-2.5	0.0	2.5	dB
			V <sub>in</sub>	V <sub>in</sub>	OUTb				
AGC Flat3	AGC <sub>FLT3</sub>	Vin=300mVrms, f=1kHz AGC="1", AGCL="10"	V <sub>in</sub>	V <sub>in</sub>	OUTa	-2.5	0.0	2.5	dB
			V <sub>in</sub>	V <sub>in</sub>	OUTb				
AGC Flat4	AGC <sub>FLT4</sub>	Vin=400mVrms, f=1kHz AGC="1", AGCL="11"	V <sub>in</sub>	V <sub>in</sub>	OUTa	-2.5	0.0	2.5	dB
			V <sub>in</sub>	V <sub>in</sub>	OUTb				
AGC Cut	AGC <sub>CUT</sub>	Vin=2Vrms, f=1kHz AGC="1"	V <sub>in</sub>	V <sub>in</sub>	OUTa	-14	-10	-6.0	dB
			V <sub>in</sub>	V <sub>in</sub>	OUTb				
<b>◆SURROUND</b>									
Surround Gain1	SR <sub>GAIN1</sub>	f=100Hz Surround Effect1	V <sub>in</sub>	-	OUTa	6.3	8.3	10.3	dB
			-	V <sub>in</sub>	OUTb				
Surround Gain2	SR <sub>GAIN2</sub>	f=100Hz Surround Effect1	V <sub>in</sub>	-	OUTb	2.1	4.1	6.1	dB
			-	V <sub>in</sub>	OUTa				
Surround Gain3	SR <sub>GAIN3</sub>	f=100 Hz Surround Effect2	V <sub>in</sub>	-	OUTa	10.7	12.7	14.7	dB
			-	V <sub>in</sub>	OUTb				
Surround Gain4	SR <sub>GAIN 4</sub>	f=100Hz Surround Effect2	V <sub>in</sub>	-	OUTb	8.4	10.4	12.4	dB
			-	V <sub>in</sub>	OUTa				
Simulated Stereo1	SR <sub>SIM1</sub>	f=1kHz, Simulated Stereo	V <sub>in</sub>	V <sub>in</sub>	OUTa	1.0	3.0	5.0	dB
Simulated Stereo2	SR <sub>SIM2</sub>	f=1kHz, Simulated Stereo	V <sub>in</sub>	V <sub>in</sub>	OUTb	1.0	3.0	5.0	dB
<b>◆AUX</b>									
AUX0 Output Voltage	V <sub>AUX0</sub>	Logic Output : High	-	-	-	4.5	-	5.5	V
		Logic Output : Mid	-	-	-	2.0	-	3.0	
		Logic Output : Low	-	-	-	0	-	0.5	
AUX1 Output Voltage	V <sub>AUX1</sub>	Logic Output : High	-	-	-	3.5	-	V+	V
		Logic Output : Low	-	-	-	0	-	0.5	

## ■ I<sup>2</sup>C BUS BLOCK CHARACTERISTICS (SDA,SCL)

I<sup>2</sup>C BUS Load Conditions: Pull up resistance 4kΩ (Connected to +5V), Load capacitance 200pF (Connected to GND)

PARAMETER	SYMBOL	Standard mode			Fast mode			UNIT
		MIN.	TYP.	MAX.	MIN.	TYP.	MAX.	
Low Level Input Voltage	V <sub>IL</sub>	0.0	-	1.5	0.0	-	1.5	V
High Level Input Voltage	V <sub>IH</sub>	2.7	-	5.0	2.7	-	5.0	V
Hysteresis of Schmitt trigger inputs	V <sub>hys</sub>	-	-	-	0.25	-	-	V
Low level output voltage (3mA at SDA pin)	V <sub>OL</sub>	0	-	0.4	0	-	0.4	V
Output fall time from V <sub>IHmin</sub> to V <sub>ILmax</sub> with a bus capacitance from 10pF to 400pF	t <sub>of</sub>	-	-	250	20 +0.1C <sub>b</sub>	-	250	ns
Pulse width of spikes which must be suppressed by the input filter	t <sub>SP</sub>	-	-	-	0	-	50	ns
Input current each I/O pin with an input voltage between 0.1V <sub>DD</sub> and 0.9V <sub>DDmax</sub>	I <sub>i</sub>	-10	-	10	-10	-	10	μA
Capacitance for each I/O pin	C <sub>i</sub>	-	-	10	-	-	10	pF
SCL clock frequency	f <sub>SCL</sub>	-	-	100	-	-	400	kHz
Hold time (repeated) START condition.	t <sub>HD:STA</sub>	4.0	-	-	0.6	-	-	μs
Low period of the SCL clock	t <sub>LOW</sub>	4.7	-	-	1.3	-	-	μs
High period of the SCL clock	t <sub>HIGH</sub>	4.0	-	-	0.6	-	-	μs
Set-up time for a repeated START condition	t <sub>SU:STA</sub>	4.7	-	-	0.6	-	-	μs
Data hold time	t <sub>HD:DAT</sub>	0	-	3.45	0	-	0.9	μs
Data set-up time	t <sub>SU:DAT</sub>	250	-	-	100	-	-	ns
Rise time of both SDA and SCL signals	t <sub>r</sub>	-	-	1000	-	-	300	ns
Fall time of both SDA and SCL signals	t <sub>f</sub>	-	-	300	-	-	300	ns
Set-up time for STOP condition	t <sub>SU:STO</sub>	4.0	-	-	0.6	-	-	μs
Bus free time between a STOP and START condition	t <sub>BUF</sub>	4.7	-	-	1.3	-	-	μs
Capacitive load for each bus line	C <sub>b</sub>	-	-	400	-	-	400	pF
Noise margin at the Low level	V <sub>nL</sub>	0.5	-	-	0.5	-	-	V
Noise margin at the High level	V <sub>nH</sub>	1	-	-	1	-	-	V

C<sub>b</sub> ; total capacitance of one bus line in pF.

I<sup>2</sup>C BUS Load Condition: Pull up resistance 4kΩ (Connected to +5V)  
Load capacitance 200pF (Connected to GND)

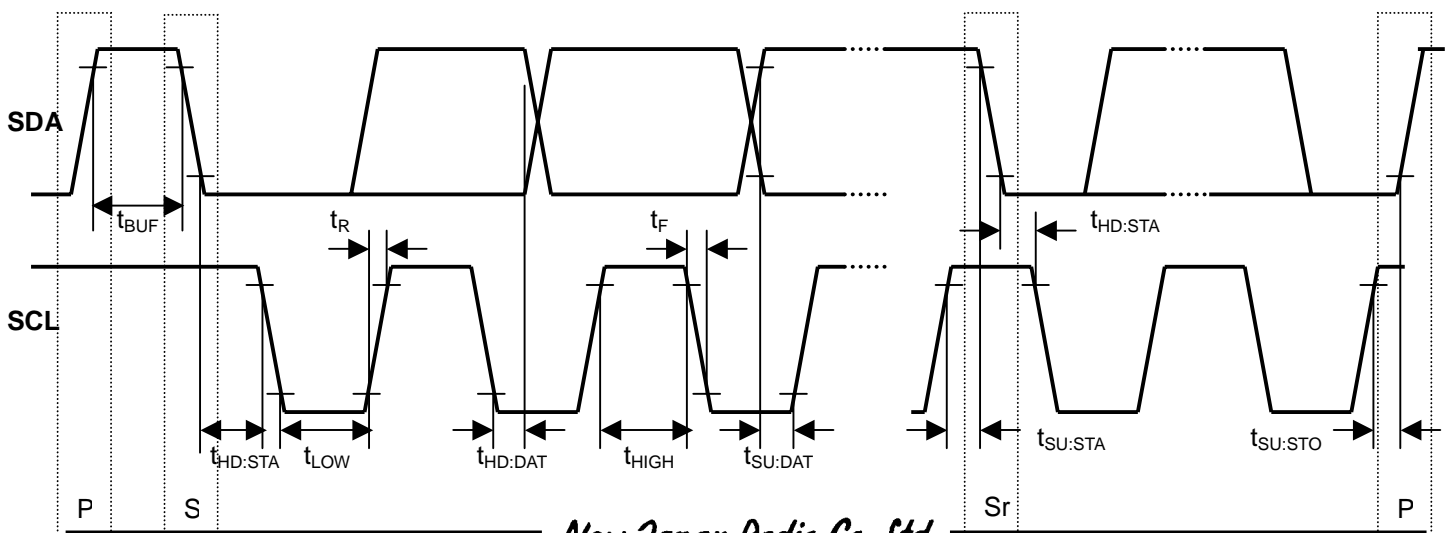

## ■ TERMINAL DESCRIPTION

No.		SYMBOL	FUNCTION	EQUIVALENT CIRCUIT	VOLTAGE
SDIP SDMP	SSOP				
1 30	1 32	INa INb	Ach input terminal Bch input terminal		V+/2
22 8 23	24 8 25	OUTw OUTa OUTb	Subwoofer output terminal Ach output terminal Bch output terminal		V+/2
10	10	SUR-FIL	Surround filter terminal		V+/2
6 25	6 27	TONE-Ha TONE-Hb	Treble(tone control) filter terminal		V+/2
7 24	7 26	TONE-La TONE-Lb	Bass(tone control) filter terminal		V+/2

## ■ TERMINAL DESCRIPTION

No.		SYMBOL	FUNCTION	EQUIVALENT CIRCUIT	VOLTAGE
SDIP SDMP	SSOP				
9	9	AGC	Capacitor connection terminal for AGC attack and recovery time setting		AGC; OFF=0.65V ON=1.4V
18	20	AUX0	Auxiliary 3 values voltage output terminal		Low=0V Mid=2.5V High= 5.0V
17	19	AUX1	Auxiliary 2 values voltage output terminal (Open collector type output)		Low=0V High=3.5V to V+
13	13	SDA	I <sup>2</sup> C data terminal		-
14	14	SCL	I <sup>2</sup> C clock terminal		-



## ■ TERMINAL DESCRIPTION

No.		SYMBOL	FUNCTION	EQUIVALENT CIRCUIT	VOLTAGE
SDIP SDMP	SSOP				
15 16	15 17	GND V+	Ground terminal Supply voltage terminal	-	0V V+
21	23	Vref	Reference voltage terminal		V+/2
19 20	21 22	CTL CTH	DAC output for tone control terminal		-
2 11 12	2 11 12	CVW CVB CVA	DAC output terminal for trimmer control DAC output terminal for Bch volume control DAC output terminal for Ach volume control		-
29 28	31 30	LF3 LF2	LPF filter terminal		V+/2+0.7V

# NJW1176

## ■ TERMINAL DESCRIPTION

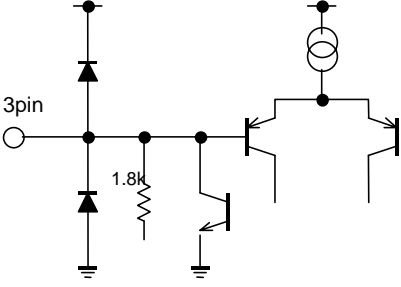
No.		SYMBOL	FUNCTION	EQUIVALENT CIRCUIT	VOLTAGE
SDIP SDMP	SSOP				
3	3	LF1	LPF filter terminal		V+/2

## MEASUREMENT CIRCUIT

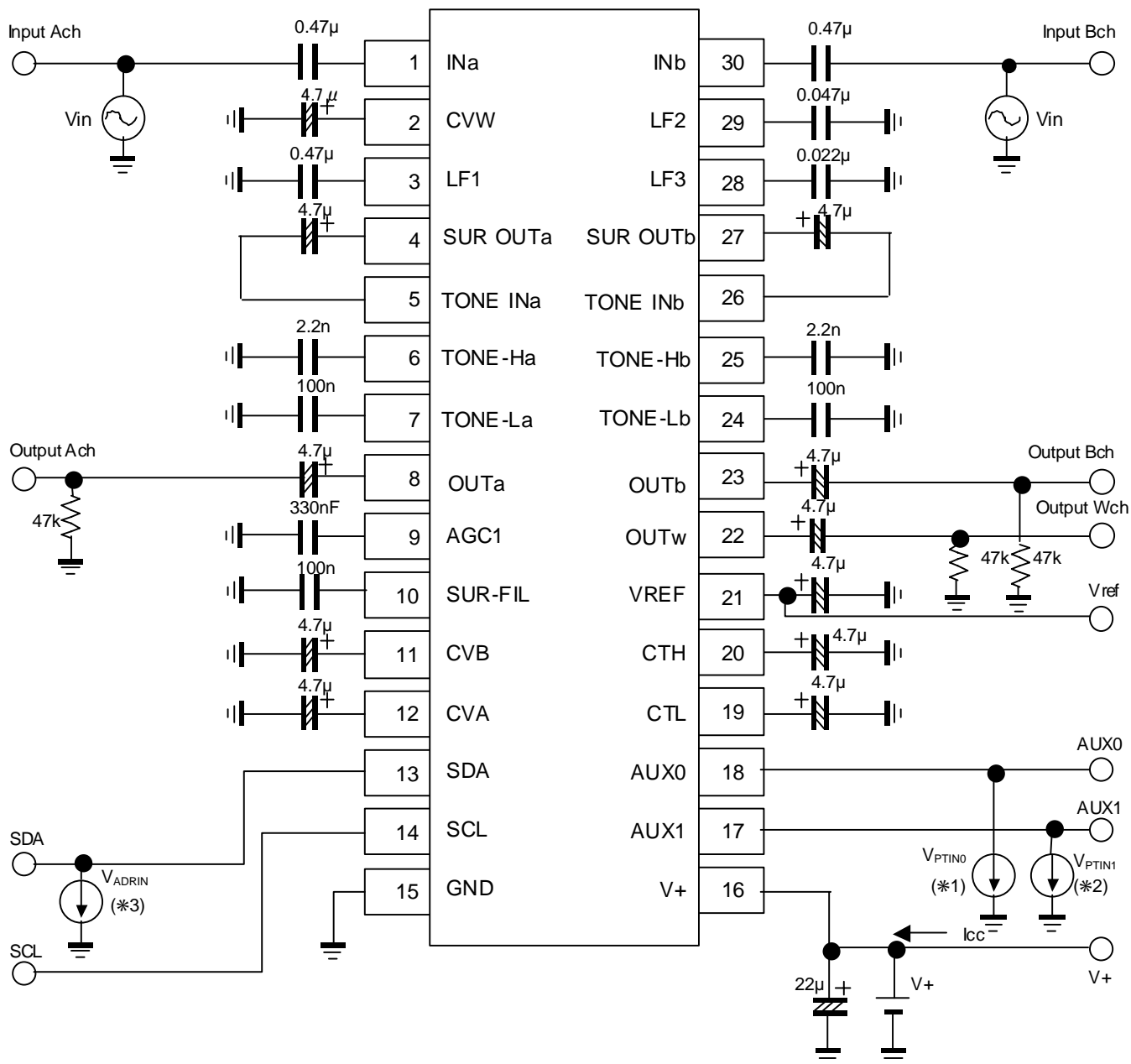

(\*1)

$V_{AUX0}$	$I_{AUX0}$
Output High	+1mA
Output Low	-120µA

(\*2)

$V_{AUX1}$	$I_{AUX1}$
Output Low	-1mA

(\*3)

$V_{OL}$	$I_{OL}$
Output Low	-3mA

## APPLICATION CIRCUIT 1 (SDIP30, SDMP30)

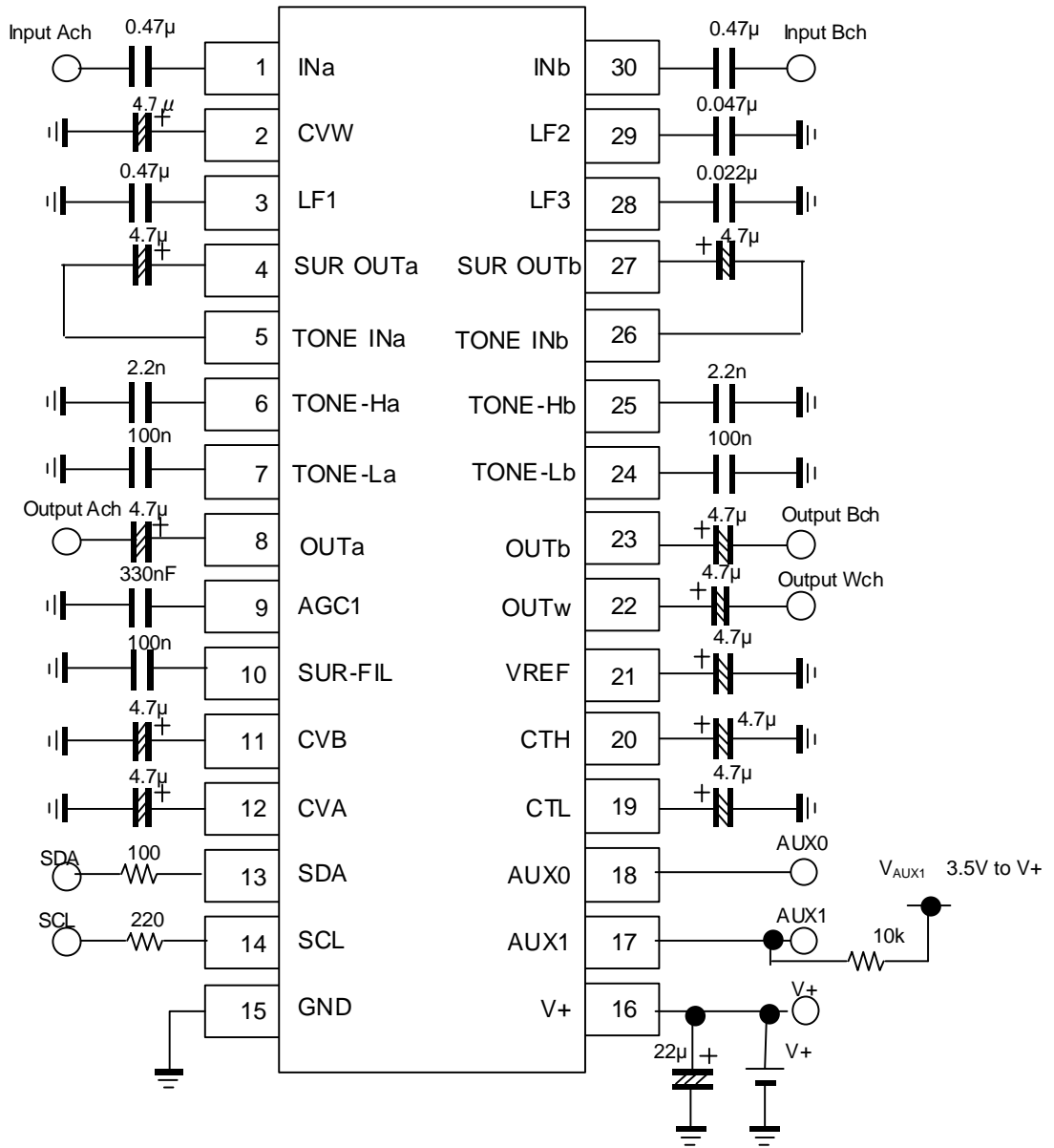

(\*4) Separate the I<sup>2</sup>C bus line and Signal line from the following terminals for avoiding digital noise problem and cross talk.

Pin No.	Symbol	Pin No.	Symbol
3	LF1	24	TONE-Lb
6	TONE-Ha	25	TONE-Hb
7	TONE-La	28	LF3
10	SUR-FIL	29	LF2

## APPLICATION CIRCUIT 2 (SDIP30, SDMP30)

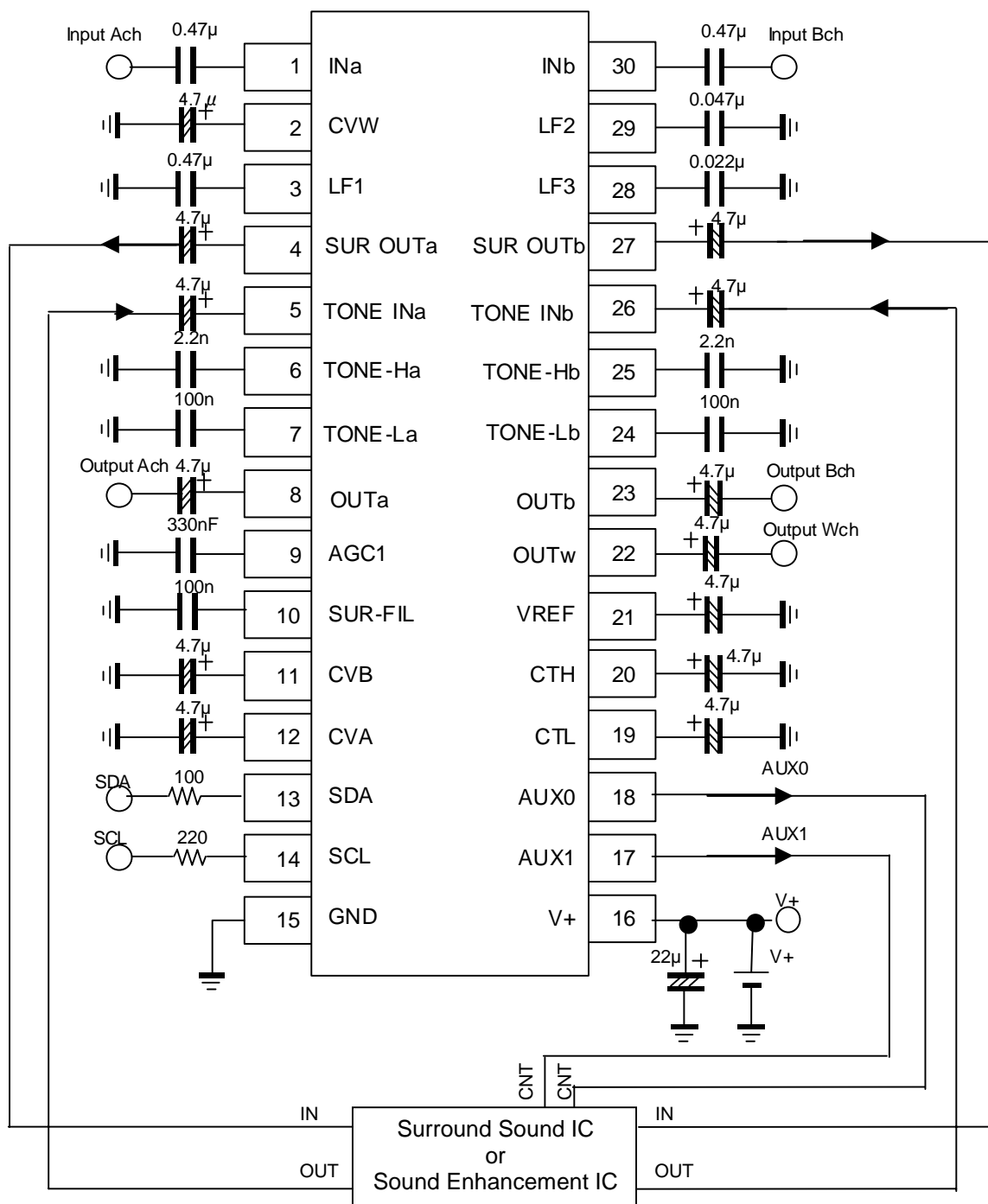

Ex.)  
 ealaBASS : NJM2706  
 BBE Mach3 : NJM2155  
 SRS TruBass : NJM2192A  
 SRS WOW : NJM2700, NJM2195, ... , etc

(\*4) Separate the I<sup>2</sup>C bus line and Signal line from the following terminals for avoiding digital noise problem and cross talk.

Pin No.	Symbol	Pin No.	Symbol
3	LF1	24	TONE-Lb
6	TONE-Ha	25	TONE-Hb
7	TONE-La	28	LF3
10	SUR-FIL	29	LF2

## APPLICATION CIRCUIT 3 (SSOP32)

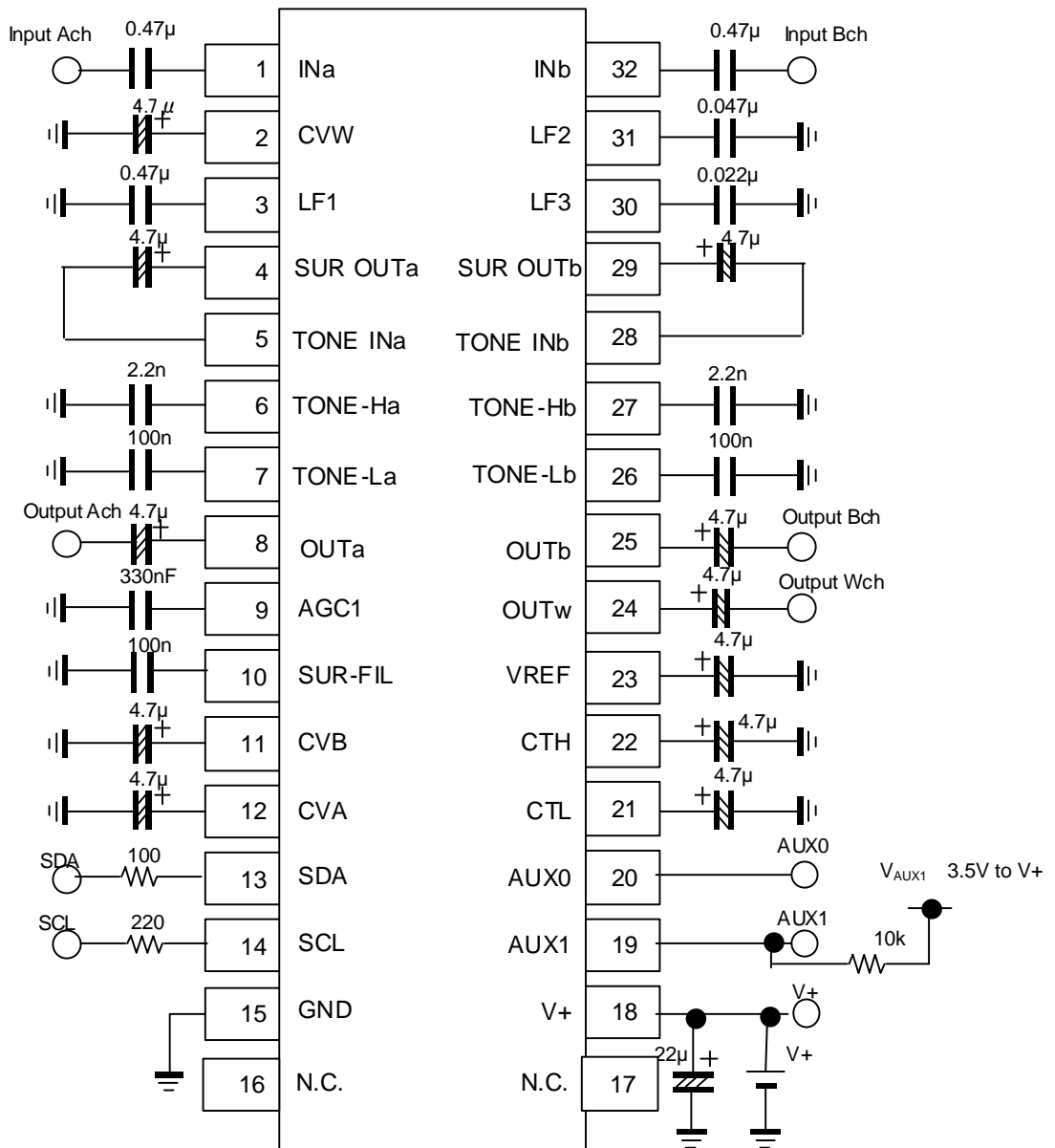

(\*4) Separate the I<sup>2</sup>C bus line and Signal line from the following terminals for avoiding digital noise problem and cross talk.

Pin No.	Symbol	Pin No.	Symbol
3	LF1	26	TONE-Lb
6	TONE-Ha	27	TONE-Hb
7	TONE-La	30	LF3
10	SUR-FIL	31	LF2

## APPLICATION CIRCUIT 4 (SSOP32)

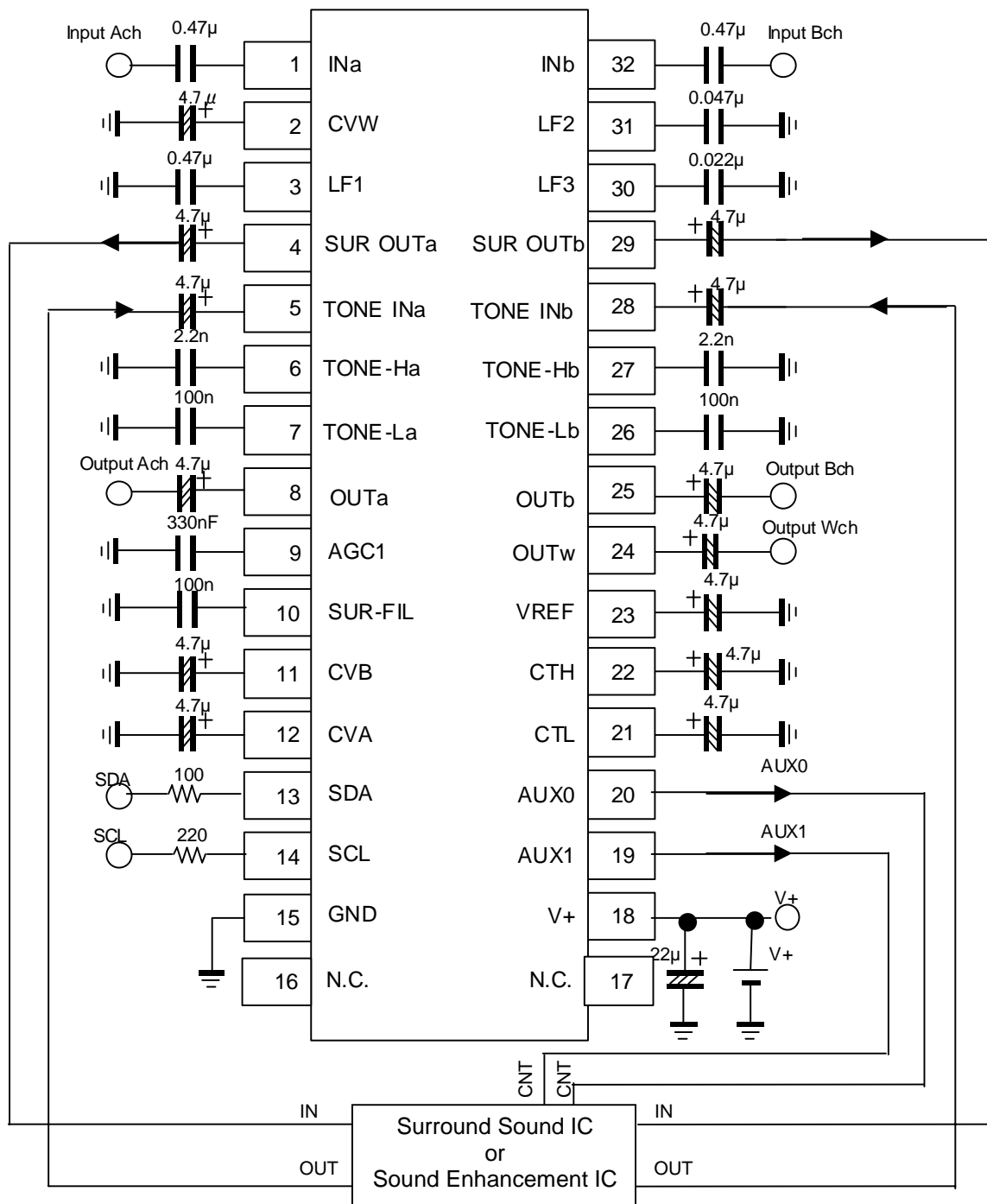

Ex.)  
 ealaBASS : NJM2706  
 BBE Mach3 : NJM2155  
 SRS TruBass : NJM2192A  
 SRS WOW : NJM2700, NJM2195, ... , etc

(\*4) Separate the I<sup>2</sup>C bus line and Signal line from the following terminals for avoiding digital noise problem and cross talk.

Pin No.	Symbol	Pin No.	Symbol
3	LF1	26	TONE-Lb
6	TONE-Ha	27	TONE-Hb
7	TONE-La	30	LF3
10	SUR-FIL	31	LF2

## ■ DEFINITION OF I<sup>2</sup>C REGISTER

### ◆ I<sup>2</sup>C BUS FORMAT

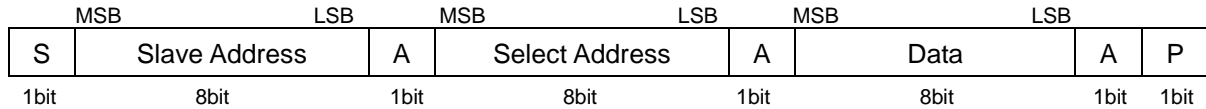

S: Starting Term  
 A: Acknowledge Bit  
 P: Ending Term

### ◆ SLAVE ADDRESS

R/W = 0: Receive Only.  
 R/W = 1: No Output Data

Slave Address								Hex
1	0	0	0	0	0	1	0	82(h)

### ◆ CONTROL REGISTER TABLE

The select address sets each function (Volume, Balance, Bass Boost Select, AGC, Surround, Tone Control, AUX).  
 The auto increment function cycles the select address as follows.  
 00H → 01H → 02H → 03H → 04H → 05H → 00H

#### <Write Mode>

Select Address	BIT							
	D7	D6	D5	D4	D3	D2	D1	D0
00H	VOL							
01H	CHS	BAL						BBSW
02H	BCB	BASS					*	
03H	BCT	TREB					*	
04H	TRIM							*
05H	SUR		AUX1	AUX0		AGCL	AGC	

\* : Don't Care

### ◆ CONTROL REGISTER DEFAULT VALUE

Control register default value is all "0".

Select Address	BIT							
	D7	D6	D5	D4	D3	D2	D1	D0
00H	0	0	0	0	0	0	0	0
01H	0	0	0	0	0	0	0	0
02H	0	0	0	0	0	0	0	0
03H	0	0	0	0	0	0	0	0
04H	0	0	0	0	0	0	0	0
05H	0	0	0	0	0	0	0	0



## ■ INSTRUCTION CODE

### a) MASTER VOLUME SETTING

Select Address	BIT							
	D7	D6	D5	D4	D3	D2	D1	D0
00H	VOL							

•VOL Attenuation level : 0 to -80dB(0.33dB/step) , MUTE

The attenuator is consisted of both the VOL1(0.165dB/step)and VOL2(0.165dB/step) and is enable to adjust 0.33dB/step. The attenuation for both the VOL1and VOL2 are always synchronized to have the same attenuation levels for each other, and are not controllable independently for each other.

ex) VOL(-30dB) = VOL1(-15dB) + VOL2(-15dB)

### b) BALANCE AND BASS BOOST FUNCTION SETTING

Select Address	BIT							
	D7	D6	D5	D4	D3	D2	D1	D0
01H	CHS	BAL						BBSW

•CHS : Channel select for balance control

“0” : Ach “Bch is attenuated”

“1” : Bch “Ach is attenuated”

•BAL : Balance control for both Ach and Bch

Balance Level : 0 to -60dB (1dB/Step) , MUTE

•BBSW : Bass Boost ON/OFF Switch

“0” = Bass Boost OFF

“1” = Bass Boost ON

### c) TONE CONTROL BASS SETTING

Select Address	BIT								
	D7	D6	D5	D4	D3	D2	D1	D0	
02H	BCB	BASS					Don't Care		

•BCB : Boost cut select for Bass control

“0” : Cut

“1” : Boost

•BASS : BASS Level Setting

Cut Level : -15 to 0dB(0.5dB/Step)

Boost Level : 0 to +15dB(0.5dB/Step)

### d) TONE CONTROL TREBLE SETTING

Select Address	BIT								
	D7	D6	D5	D4	D3	D2	D1	D0	
03H	BCT	TREB					Don't Care		

•BCT : Boost cut select for Treble control

“0” : Cut

“1” : Boost

•TREB : TREBLE Level Setting

Cut Level : -15 to 0dB(0.5dB/Step)

Boost Level : 0 to +15dB(0.5dB/Step)

### e) TRIMMER LEVEL SETTING

Select Address	BIT							
	D7	D6	D5	D4	D3	D2	D1	D0
04H	TRIM							Don't Care

•TRIM : Trimmer Level

Trimmer Level : +18 to -44dB (0.5dB/Step) , MUTE

**d) SURROUND, AUXILIARY, AGC LEVEL SETTING**

Select Address	BIT							
	D7	D6	D5	D4	D3	D2	D1	D0
05H	SUR		AUX1	AUX0		AGCL		AGC

**<SUR : Surround Level Setting>**

Surround Setting	D7	D6	Remarks
Surround Off	0	0	Surround Off
Simulated Stereo	0	1	Simulated Stereo
Surround Effect1	1	0	Surround Effect Low(8.3dB typ.)
Surround Effect2	1	1	Surround Effect High(12.7dB typ.)

**<AUX1 : AUX1 Terminal Setting>**

Auxiliary Setting	D5
Low (0.0V)	0
High (5.0V)	1

**<AUX0 : AUX0 Terminal Setting>**

Auxiliary Setting	D4	D3
Low (0.0V)	-	0
Mid (2.5V)	0	1
High (5.0V)	1	1

**<AGCL : AGC Level Setting>**

AGC Level Setting	D2	D1
100mVrms	0	0
200mVrms	0	1
300mVrms	1	0
400mVrms	1	1

**<AGC : AGC Setting>**

AGC Setting	D0
OFF	0
ON	1

■Master Volume (Select Address : 00H)

		VOL							
		D7	D6	D5	D4	D3	D2	D1	D0
Gain(dB)	HEX								
0	FF	1	1	1	1	1	1	1	1
-1	FC	1	1	1	1	1	1	0	0
-2	F9	1	1	1	1	1	0	0	1
-3	F6	1	1	1	1	0	1	1	0
-4	F3	1	1	1	1	0	0	1	1
-5	F0	1	1	1	1	0	0	0	0
-6	ED	1	1	1	0	1	1	0	1
-7	EA	1	1	1	0	1	0	1	0
-8	E7	1	1	1	0	0	1	1	1
-9	E4	1	1	1	0	0	1	0	0
-10	E1	1	1	1	0	0	0	0	1
-11	DE	1	1	0	1	1	1	1	0
-12	DB	1	1	0	1	1	0	1	1
-13	D8	1	1	0	1	1	0	0	0
-14	D5	1	1	0	1	0	1	0	1
-15	D2	1	1	0	1	0	0	1	0
-16	CF	1	1	0	0	1	1	1	1
-17	CC	1	1	0	0	1	1	0	0
-18	C9	1	1	0	0	1	0	0	1
-19	C6	1	1	0	0	0	1	1	0
-20	C3	1	1	0	0	0	0	1	1
-21	C0	1	1	0	0	0	0	0	0
-22	BD	1	0	1	1	1	1	0	1
-23	BA	1	0	1	1	1	0	1	0
-24	B7	1	0	1	1	0	1	1	1
-25	B4	1	0	1	1	0	1	0	0
-26	B1	1	0	1	1	0	0	0	1
-27	AE	1	0	1	0	1	1	1	0
-28	AB	1	0	1	0	1	0	1	1
-29	A8	1	0	1	0	1	0	0	0
-30	A5	1	0	1	0	0	1	0	1
-31	A2	1	0	1	0	0	0	1	0
-32	9F	1	0	0	1	1	1	1	1
-33	9C	1	0	0	1	1	1	0	0
-34	99	1	0	0	1	1	0	0	1
-35	96	1	0	0	1	0	1	1	0
-36	93	1	0	0	1	0	0	1	1
-37	90	1	0	0	1	0	0	0	0
-38	8D	1	0	0	0	1	1	0	1
-39	8A	1	0	0	0	1	0	1	0
-40	87	1	0	0	0	0	1	1	1
-41	84	1	0	0	0	0	1	0	0
-42	81	1	0	0	0	0	0	0	1

		VOL							
Gain(dB)	HEX	D7	D6	D5	D4	D3	D2	D1	D0
-43	7E	0	1	1	1	1	1	1	0
-44	7B	0	1	1	1	1	0	1	1
-45	78	0	1	1	1	1	0	0	0
-46	75	0	1	1	1	0	1	0	1
-47	72	0	1	1	1	0	0	1	0
-48	6F	0	1	1	0	1	1	1	1
-49	6C	0	1	1	0	1	1	0	0
-50	69	0	1	1	0	1	0	0	1
-51	66	0	1	1	0	0	1	1	0
-52	63	0	1	1	0	0	0	1	1
-53	60	0	1	1	0	0	0	0	0
-54	5D	0	1	0	1	1	1	0	1
-55	5A	0	1	0	1	1	0	1	0
-56	57	0	1	0	1	0	1	1	1
-57	54	0	1	0	1	0	1	0	0
-58	51	0	1	0	1	0	0	0	1
-59	4E	0	1	0	0	1	1	1	0
-60	4B	0	1	0	0	1	0	1	1
-61	48	0	1	0	0	1	0	0	0
-62	45	0	1	0	0	0	1	0	1
-63	42	0	1	0	0	0	0	1	0
-64	3F	0	0	1	1	1	1	1	1
-65	3C	0	0	1	1	1	1	0	0
-66	39	0	0	1	1	1	0	0	1
-67	36	0	0	1	1	0	1	1	0
-68	33	0	0	1	1	0	0	1	1
-69	30	0	0	1	1	0	0	0	0
-70	2D	0	0	1	0	1	1	0	1
-71	2A	0	0	1	0	1	0	1	0
-72	27	0	0	1	0	0	1	1	1
-73	24	0	0	1	0	0	1	0	0
-74	21	0	0	1	0	0	0	0	1
-75	1E	0	0	0	1	1	1	1	0
-76	1B	0	0	0	1	1	0	1	1
-77	18	0	0	0	1	1	0	0	0
-78	15	0	0	0	1	0	1	0	1
-79	12	0	0	0	1	0	0	1	0
-80	0F	0	0	0	0	1	1	1	1
MUTE*	00	0	0	0	0	0	0	0	0

\* : Default Value

**Balance, Bass Boost Setting (Select Address : 01H)**

Channel Setting (CHS)	D7
Decrease Bch Gain	0
Decrease Ach Gain	1

Gain(dB)	BAL					
	D6	D5	D4	D3	D2	D1
0*	0	0	0	0	0	0
-1	0	0	0	0	0	1
-2	0	0	0	0	1	0
-3	0	0	0	0	1	1
-4	0	0	0	1	0	0
-5	0	0	0	1	0	1
-6	0	0	0	1	1	0
-7	0	0	0	1	1	1
-8	0	0	1	0	0	0
-9	0	0	1	0	0	1
-10	0	0	1	0	1	0
-11	0	0	1	0	1	1
-12	0	0	1	1	0	0
-13	0	0	1	1	0	1
-14	0	0	1	1	1	0
-15	0	0	1	1	1	1
-16	0	1	0	0	0	0
-17	0	1	0	0	0	1
-18	0	1	0	0	1	0
-19	0	1	0	0	1	1
-20	0	1	0	1	0	0
-21	0	1	0	1	0	1
-22	0	1	0	1	1	0
-23	0	1	0	1	1	1
-24	0	1	1	0	0	0
-25	0	1	1	0	0	1
-26	0	1	1	0	1	0
-27	0	1	1	0	1	1
-28	0	1	1	1	0	0
-29	0	1	1	1	0	1
-30	0	1	1	1	1	0

\* : Default Value

Gain(dB)	BAL					
	D6	D5	D4	D3	D2	D1
-31	0	1	1	1	1	1
-32	1	0	0	0	0	0
-33	1	0	0	0	0	1
-34	1	0	0	0	1	0
-35	1	0	0	0	1	1
-36	1	0	0	1	0	0
-37	1	0	0	1	0	1
-38	1	0	0	1	1	0
-39	1	0	0	1	1	1
-40	1	0	1	0	0	0
-41	1	0	1	0	0	1
-42	1	0	1	0	1	0
-43	1	0	1	0	1	1
-44	1	0	1	1	0	0
-45	1	0	1	1	0	1
-46	1	0	1	1	1	0
-47	1	0	1	1	1	1
-48	1	1	0	0	0	0
-49	1	1	0	0	0	1
-50	1	1	0	0	1	0
-51	1	1	0	0	1	1
-52	1	1	0	1	0	0
-53	1	1	0	1	0	1
-54	1	1	0	1	1	0
-55	1	1	0	1	1	1
-56	1	1	1	0	0	0
-57	1	1	1	0	0	1
-58	1	1	1	0	1	0
-59	1	1	1	0	1	1
-60	1	1	1	1	0	0
MUTE	1	1	1	1	1	1

Bass Boost Setting (BBSW)	D0
Bass Boost Off*	0
Bass Boost On	1

\* : Default Value

■Tone Control(Bass Setting) (Select Address : 02H)

<b>Bass Cut or Boost</b>	<b>BCB</b>
	<b>D7</b>
Cut	0
Boost	1

Cut Gain(dB) / Boost Gain(dB)		BASS				
Cut Gain(dB)	Boost Gain(dB)	D6	D5	D4	D3	D2
-15.0	15.0	1	1	1	1	0
-14.5	14.5	1	1	1	0	1
-14.0	14.0	1	1	1	0	0
-13.5	13.5	1	1	0	1	1
-13.0	13.0	1	1	0	1	0
-12.5	12.5	1	1	0	0	1
-12.0	12.0	1	1	0	0	0
-11.5	11.5	1	0	1	1	1
-11.0	11.0	1	0	1	1	0
-10.5	10.5	1	0	1	0	1
-10.0	10.0	1	0	1	0	0
-9.5	9.5	1	0	0	1	1
-9.0	9.0	1	0	0	1	0
-8.5	8.5	1	0	0	0	1
-8.0	8.0	1	0	0	0	0
-7.5	7.5	0	1	1	1	1
-7.0	7.0	0	1	1	1	0
-6.5	6.5	0	1	1	0	1
-6.0	6.0	0	1	1	0	0
-5.5	5.5	0	1	0	1	1
-5.0	5.0	0	1	0	1	0
-4.5	4.5	0	1	0	0	1
-4.0	4.0	0	1	0	0	0
-3.5	3.5	0	0	1	1	1
-3.0	3.0	0	0	1	1	0
-2.5	2.5	0	0	1	0	1
-2.0	2.0	0	0	1	0	0
-1.5	1.5	0	0	0	1	1
-1.0	1.0	0	0	0	1	0
-0.5	0.5	0	0	0	0	1
0.0*	0.0*	0	0	0	0	0

\* : Default value

■Tone Control(Treble Setting) (Select Address : 03H)

Treble Cut or Boost	BCT
	D7
Cut	0
Boost	1

		TREB				
Cut Gain(dB)	Boost Gain(dB)	D6	D5	D4	D3	D2
-15.0	15.0	1	1	1	1	0
-14.5	14.5	1	1	1	0	1
-14.0	14.0	1	1	1	0	0
-13.5	13.5	1	1	0	1	1
-13.0	13.0	1	1	0	1	0
-12.5	12.5	1	1	0	0	1
-12.0	12.0	1	1	0	0	0
-11.5	11.5	1	0	1	1	1
-11.0	11.0	1	0	1	1	0
-10.5	10.5	1	0	1	0	1
-10.0	10.0	1	0	1	0	0
-9.5	9.5	1	0	0	1	1
-9.0	9.0	1	0	0	1	0
-8.5	8.5	1	0	0	0	1
-8.0	8.0	1	0	0	0	0
-7.5	7.5	0	1	1	1	1
-7.0	7.0	0	1	1	1	0
-6.5	6.5	0	1	1	0	1
-6.0	6.0	0	1	1	0	0
-5.5	5.5	0	1	0	1	1
-5.0	5.0	0	1	0	1	0
-4.5	4.5	0	1	0	0	1
-4.0	4.0	0	1	0	0	0
-3.5	3.5	0	0	1	1	1
-3.0	3.0	0	0	1	1	0
-2.5	2.5	0	0	1	0	1
-2.0	2.0	0	0	1	0	0
-1.5	1.5	0	0	0	1	1
-1.0	1.0	0	0	0	1	0
-0.5	0.5	0	0	0	0	1
0.0*	0.0*	0	0	0	0	0

\* : Default value



■ Trimmer Setting (Select Address: 04H)

Gain(dB)	TRIM						
	D7	D6	D5	D4	D3	D2	D1
+18.0	1	1	1	1	1	1	1
+17.5	1	1	1	1	1	1	0
+17.0	1	1	1	1	1	0	1
+16.5	1	1	1	1	1	0	0
+16.0	1	1	1	1	0	1	1
+15.5	1	1	1	1	0	1	0
+15.0	1	1	1	1	0	0	1
+14.5	1	1	1	1	0	0	0
+14.0	1	1	1	0	1	1	1
+13.5	1	1	1	0	1	1	0
+13.0	1	1	1	0	1	0	1
+12.5	1	1	1	0	1	0	0
+12.0	1	1	1	0	0	1	1
+11.5	1	1	1	0	0	1	0
+11.0	1	1	1	0	0	0	1
+10.5	1	1	1	0	0	0	0
+10.0	1	1	0	1	1	1	1
+9.5	1	1	0	1	1	1	0
+9.0	1	1	0	1	1	0	1
+8.5	1	1	0	1	1	0	0
+8.0	1	1	0	1	0	1	1
+7.5	1	1	0	1	0	1	0
+7.0	1	1	0	1	0	0	1
+6.5	1	1	0	1	0	0	0
+6.0	1	1	0	0	1	1	1
+5.5	1	1	0	0	1	1	0
+5.0	1	1	0	0	1	0	1
+4.5	1	1	0	0	1	0	0
+4.0	1	1	0	0	0	1	1
+3.5	1	1	0	0	0	1	0
+3.0	1	1	0	0	0	0	1
+2.5	1	1	0	0	0	0	0
+2.0	1	0	1	1	1	1	1
+1.5	1	0	1	1	1	1	0
+1.0	1	0	1	1	1	0	1
+0.5	1	0	1	1	1	0	0
0.0	1	0	1	1	0	1	1
-0.5	1	0	1	1	0	1	0
-1.0	1	0	1	1	0	0	1
-1.5	1	0	1	1	0	0	0
-2.0	1	0	1	0	1	1	1
-2.5	1	0	1	0	1	1	0
-3.0	1	0	1	0	1	0	1
-3.5	1	0	1	0	1	0	0
-4.0	1	0	1	0	0	1	1
-4.5	1	0	1	0	0	1	0
-5.0	1	0	1	0	0	0	1
-5.5	1	0	1	0	0	0	0
-6.0	1	0	0	1	1	1	1

Gain(dB)	TRIM						
	D7	D6	D5	D4	D3	D2	D1
-6.5	1	0	0	1	1	1	0
-7.0	1	0	0	1	1	0	1
-7.5	1	0	0	1	1	0	0
-8.0	1	0	0	1	0	1	1
-8.5	1	0	0	1	0	1	0
-9.0	1	0	0	1	0	0	1
-9.5	1	0	0	1	0	0	0
-10.0	1	0	0	0	1	1	1
-10.5	1	0	0	0	1	1	0
-11.0	1	0	0	0	1	0	1
-11.5	1	0	0	0	1	0	0
-12.0	1	0	0	0	0	1	1
-12.5	1	0	0	0	0	1	0
-13.0	1	0	0	0	0	0	1
-13.5	1	0	0	0	0	0	0
-14.0	0	1	1	1	1	1	1
-14.5	0	1	1	1	1	1	0
-15.0	0	1	1	1	1	0	1
-15.5	0	1	1	1	1	0	0
-16.0	0	1	1	1	0	1	1
-16.5	0	1	1	1	0	1	0
-17.0	0	1	1	1	0	0	1
-17.5	0	1	1	1	0	0	0
-18.0	0	1	1	0	1	1	1
-18.5	0	1	1	0	1	1	0
-19.0	0	1	1	0	1	0	1
-19.5	0	1	1	0	1	0	0
-20.0	0	1	1	0	0	1	1
-20.5	0	1	1	0	0	1	0
-21.0	0	1	1	0	0	0	1
-21.5	0	1	1	0	0	0	0
-22.0	0	1	0	1	1	1	1
-22.5	0	1	0	1	1	1	0
-23.0	0	1	0	1	1	0	1
-23.5	0	1	0	1	1	0	0
-24.0	0	1	0	1	0	1	1
-24.5	0	1	0	1	0	1	0
-25.0	0	1	0	1	0	0	1
-25.5	0	1	0	1	0	0	0
-26.0	0	1	0	0	1	1	1
-26.5	0	1	0	0	1	1	0
-27.0	0	1	0	0	1	0	1
-27.5	0	1	0	0	1	0	0
-28.0	0	1	0	0	0	1	1
-28.5	0	1	0	0	0	1	0
-29.0	0	1	0	0	0	0	1
-29.5	0	1	0	0	0	0	0
-30.0	0	0	1	1	1	1	1
-30.5	0	0	1	1	1	1	0
-31.0	0	0	1	1	1	0	1

Gain (dB)	TRIM						
	D7	D6	D5	D4	D3	D2	D1
-31.5	0	0	1	1	1	0	0
-32.0	0	0	1	1	0	1	1
-32.5	0	0	1	1	0	1	0
-33.0	0	0	1	1	0	0	1
-33.5	0	0	1	1	0	0	0
-34.0	0	0	1	0	1	1	1
-34.5	0	0	1	0	1	1	0
-35.0	0	0	1	0	1	0	1
-35.5	0	0	1	0	1	0	0
-36.0	0	0	1	0	0	1	1
-36.5	0	0	1	0	0	1	0
-37.0	0	0	1	0	0	0	1
-37.5	0	0	1	0	0	0	0
-38.0	0	0	0	1	1	1	1
-38.5	0	0	0	1	1	1	0
-39.0	0	0	0	1	1	0	1
-39.5	0	0	0	1	1	0	0
-40.0	0	0	0	1	0	1	1
-40.5	0	0	0	1	0	1	0
-41.0	0	0	0	1	0	0	1
-41.5	0	0	0	1	0	0	0
-42.0	0	0	0	0	1	1	1
-42.5	0	0	0	0	1	1	0
-43.0	0	0	0	0	1	0	1
-43.5	0	0	0	0	1	0	0
-44.0	0	0	0	0	0	1	1
MUTE*	0	0	0	0	0	0	0

\* : Default value

[CAUTION]  
 The specifications on this databook are only given for information, without any guarantee as regards either mistakes or omissions. The application circuits in this databook are described only to show representative usages of the product and not intended for the guarantee or permission of any right including the industrial rights.