

| | |
|---------------|-----------|
| Spec. No. | |
| Version : | 1 |
| Total pages : | 15 |
| Date : | 2002.4.11 |

Product Specification

20.1" COLOR TFT-LCD MODULE

MODEL NAME: A201SN01 V.0

< ◆ > Preliminary Specification

< > Final Specification

Note: The content of this specification is subject to change.

© 2002 AU Optronics
All Rights Reserved,
Do Not Copy.

Record of Revision

| Version | Revise Date | Page | Content | | | | | | | | | | | | | | | | | | | | | | | | | | | | | | | | | | | | | | | | | | | | | | | | | | | | | | | | |
|-------------------|--------------|------------|---|--------|------|------|------|-----------------|----------|--|----------|----------------|--|---------|----------|-------------------|--|--|---------|--------|------|------|------|----------------|---------|---------|---------|----------------|------|--------|--|----------------|--|------------|--|----------------|--|---------|--|--------|------|------|------|----------------|--|-------|-------|----------------|--|---------|---------|----------------|------------|------------|------------|----------------|------------|------------|------------|
| 0 | 15/Dec./2001 | | First draft. | | | | | | | | | | | | | | | | | | | | | | | | | | | | | | | | | | | | | | | | | | | | | | | | | | | | | | | | |
| 1 | 11/Apr./2002 | | <p>1. Total pages 14→15</p> <p>2. Overall dimension H : 345 →347 D : 25 → 23</p> <p>3. Typical operation (Page 4)</p> <table border="1" style="margin-left: 20px; border-collapse: collapse; width: 80%;"> <thead> <tr> <th style="width: 25%;">Symbol</th> <th style="width: 25%;">Min.</th> <th style="width: 25%;">Typ.</th> <th style="width: 25%;">Max.</th> </tr> </thead> <tbody> <tr> <td style="text-align: center;">V_{CC}</td> <td style="text-align: center;">4.7→4.75</td> <td></td> <td style="text-align: center;">5.3→5.25</td> </tr> <tr> <td style="text-align: center;">I_A</td> <td></td> <td style="text-align: center;">700→800</td> <td style="text-align: center;">800→1000</td> </tr> <tr> <td style="text-align: center;">I_{RUSH}</td> <td></td> <td></td> <td style="text-align: center;">TBD→1.5</td> </tr> </tbody> </table> <p>4. Timing characteristic of input signal (Page 6) Add H/V input mode</p> <p>5. Black light unit (Page 7)</p> <table border="1" style="margin-left: 20px; border-collapse: collapse; width: 80%;"> <thead> <tr> <th style="width: 25%;">Symbol</th> <th style="width: 25%;">Min.</th> <th style="width: 25%;">Typ.</th> <th style="width: 25%;">Max.</th> </tr> </thead> <tbody> <tr> <td style="text-align: center;">V_L</td> <td style="text-align: center;">740→720</td> <td style="text-align: center;">820→800</td> <td style="text-align: center;">900→880</td> </tr> <tr> <td style="text-align: center;">I_L</td> <td style="text-align: center;">5 →4</td> <td style="text-align: center;">6 →5.5</td> <td></td> </tr> <tr> <td style="text-align: center;">P_L</td> <td></td> <td style="text-align: center;">4.92→4.4X6</td> <td></td> </tr> <tr> <td style="text-align: center;">F_L</td> <td></td> <td style="text-align: center;">50 → 52</td> <td></td> </tr> </tbody> </table> <p>6. Optical specification (Page 8)</p> <table border="1" style="margin-left: 20px; border-collapse: collapse; width: 80%;"> <thead> <tr> <th style="width: 25%;">Symbol</th> <th style="width: 25%;">Min.</th> <th style="width: 25%;">Typ.</th> <th style="width: 25%;">Max.</th> </tr> </thead> <tbody> <tr> <td style="text-align: center;">T_r</td> <td></td> <td style="text-align: center;">4 → 6</td> <td style="text-align: center;">8 →10</td> </tr> <tr> <td style="text-align: center;">T_f</td> <td></td> <td style="text-align: center;">12 → 16</td> <td style="text-align: center;">24 → 25</td> </tr> <tr> <td style="text-align: center;">W_x</td> <td style="text-align: center;">0.283→0.25</td> <td style="text-align: center;">0.313→0.28</td> <td style="text-align: center;">0.343→0.31</td> </tr> <tr> <td style="text-align: center;">W_y</td> <td style="text-align: center;">0.299→0.27</td> <td style="text-align: center;">0.329→0.30</td> <td style="text-align: center;">0.359→0.33</td> </tr> </tbody> </table> <p>7. Driving condition for CCFL (Page 9) I_L : 6 →5.5mA 50 → 52KHz</p> <p>8. Reliability test items (Page 10) High temp. storage 70→60 Thermal shock 70 →60</p> <p>9. Update outline dimension drawing (Page 12)</p> | Symbol | Min. | Typ. | Max. | V _{CC} | 4.7→4.75 | | 5.3→5.25 | I _A | | 700→800 | 800→1000 | I _{RUSH} | | | TBD→1.5 | Symbol | Min. | Typ. | Max. | V _L | 740→720 | 820→800 | 900→880 | I _L | 5 →4 | 6 →5.5 | | P _L | | 4.92→4.4X6 | | F _L | | 50 → 52 | | Symbol | Min. | Typ. | Max. | T _r | | 4 → 6 | 8 →10 | T _f | | 12 → 16 | 24 → 25 | W _x | 0.283→0.25 | 0.313→0.28 | 0.343→0.31 | W _y | 0.299→0.27 | 0.329→0.30 | 0.359→0.33 |
| Symbol | Min. | Typ. | Max. | | | | | | | | | | | | | | | | | | | | | | | | | | | | | | | | | | | | | | | | | | | | | | | | | | | | | | | | |
| V _{CC} | 4.7→4.75 | | 5.3→5.25 | | | | | | | | | | | | | | | | | | | | | | | | | | | | | | | | | | | | | | | | | | | | | | | | | | | | | | | | |
| I _A | | 700→800 | 800→1000 | | | | | | | | | | | | | | | | | | | | | | | | | | | | | | | | | | | | | | | | | | | | | | | | | | | | | | | | |
| I _{RUSH} | | | TBD→1.5 | | | | | | | | | | | | | | | | | | | | | | | | | | | | | | | | | | | | | | | | | | | | | | | | | | | | | | | | |
| Symbol | Min. | Typ. | Max. | | | | | | | | | | | | | | | | | | | | | | | | | | | | | | | | | | | | | | | | | | | | | | | | | | | | | | | | |
| V _L | 740→720 | 820→800 | 900→880 | | | | | | | | | | | | | | | | | | | | | | | | | | | | | | | | | | | | | | | | | | | | | | | | | | | | | | | | |
| I _L | 5 →4 | 6 →5.5 | | | | | | | | | | | | | | | | | | | | | | | | | | | | | | | | | | | | | | | | | | | | | | | | | | | | | | | | | |
| P _L | | 4.92→4.4X6 | | | | | | | | | | | | | | | | | | | | | | | | | | | | | | | | | | | | | | | | | | | | | | | | | | | | | | | | | |
| F _L | | 50 → 52 | | | | | | | | | | | | | | | | | | | | | | | | | | | | | | | | | | | | | | | | | | | | | | | | | | | | | | | | | |
| Symbol | Min. | Typ. | Max. | | | | | | | | | | | | | | | | | | | | | | | | | | | | | | | | | | | | | | | | | | | | | | | | | | | | | | | | |
| T _r | | 4 → 6 | 8 →10 | | | | | | | | | | | | | | | | | | | | | | | | | | | | | | | | | | | | | | | | | | | | | | | | | | | | | | | | |
| T _f | | 12 → 16 | 24 → 25 | | | | | | | | | | | | | | | | | | | | | | | | | | | | | | | | | | | | | | | | | | | | | | | | | | | | | | | | |
| W _x | 0.283→0.25 | 0.313→0.28 | 0.343→0.31 | | | | | | | | | | | | | | | | | | | | | | | | | | | | | | | | | | | | | | | | | | | | | | | | | | | | | | | | |
| W _y | 0.299→0.27 | 0.329→0.30 | 0.359→0.33 | | | | | | | | | | | | | | | | | | | | | | | | | | | | | | | | | | | | | | | | | | | | | | | | | | | | | | | | |

Contents:

| | |
|--|------------|
| A. Physical specifications | P2 |
| B. Electrical specifications | P3 |
| 1. Pin assignment..... | P3 |
| 2. Absolute maximum ratings..... | P3 |
| 3. Electrical characteristics..... | P4 |
| a. Typical operating conditions..... | P4 |
| b. Display color v. s. input data signals..... | P5 |
| c. Input signal timing..... | P6 |
| d. Display position..... | P7 |
| e. Backlight unit..... | P7 |
| C. Optical specifications | P8 |
| D. Reliability test items | P10 |
| E. Display quality | P11 |
| F. Handling precaution | P11 |
| G. Packing form | P11 |
| Appendix: | |
| Fig.1 LCM outline dimensions | P12 |
| Fig.2 Timing chart..... | P13 |

A. Physical specifications

| NO. | Item | Specification | Remark |
|-----|---------------------------|--------------------------|--------|
| 1 | Display resolution(pixel) | 800x3(H)x600(V) | |
| 2 | Active area(mm) | 408(H)x306(V) | |
| 3 | Screen size(inch) | 20.1(Diagonal) | |
| 4 | Pixel pitch(mm) | 0.51(H)x0.51(V) | |
| 5 | Color configuration | R. G. B. Vertical stripe | |
| 6 | Overall dimension(mm) | 448(W)x347(H)x23(D) | Note 1 |
| 7 | Weight(g) | 3500 | |

Note 1: Refer to Fig. 1.

B. Electrical specifications

1. Pin assignment

| P/N | Symbol | Function | | P/N | Symbol | Function | |
|-----|-----------------|---------------------|--------|-----|--------|------------|--------|
| 1 | NC | | | 26 | R0 | Red Data | |
| 2 | NC | | | 27 | GND | Ground | |
| 3 | NC | | | 28 | G7 | Green Data | |
| 4 | GND | Ground | | 29 | G6 | | |
| 5 | GND | Ground | | 30 | G5 | | |
| 6 | V _{CC} | Power Input (+5.0V) | | 31 | G4 | | |
| 7 | V _{CC} | | | 32 | GND | Ground | |
| 8 | V _{CC} | | | 33 | G3 | Green Data | |
| 9 | V _{CC} | | | 34 | G2 | | |
| 10 | GND | | 35 | G1 | | | |
| 11 | HSYNC | Horizontal Sync. | Active | 36 | G0 | Ground | |
| 12 | VSYNC | Vertical Sync. | Low | 37 | GND | | |
| 13 | GND | | | 38 | B7 | Blue Data | |
| 14 | DE | Data Enable | | 39 | B6 | | |
| 15 | GND | | | 40 | B5 | | |
| 16 | DCLK | Dot Clock | | 41 | B4 | Blue Data | |
| 17 | GND | Ground | | 42 | GND | | Ground |
| 18 | R7 | Red Data (R7 :MSB) | | 43 | B3 | | |
| 19 | R6 | | | 44 | B2 | | |
| 20 | R5 | | | 45 | B1 | | |
| 21 | R4 | | | 46 | B0 | | |
| 22 | GND | Ground | | 47 | GND | Ground | |
| 23 | R3 | Red Data | | 48 | GND | Ground | |
| 24 | R2 | | | 49 | NC | | |
| 25 | R1 | | | 50 | NC | | |

CN1 (50P) connector: Hirose FH12-50S-0.5SH or compatible

2. Absolute maximum ratings

(GND = 0 V)

| Parameter | Symbol | Values | | Unit | Remark |
|-----------------------|-----------------|--------|----------------------|-----------------|---------|
| | | Min. | Max. | | |
| Power voltage | V _{CC} | -0.3 | 5.5 | V _{DC} | At 25°C |
| Input signal voltage | V _{LH} | -0.3 | V _{CC} +0.3 | V _{DC} | At 25°C |
| Operating temperature | T _{OP} | 0 | +50 | °C | Note 1 |
| Storage temperature | T _{ST} | -20 | +70 | °C | Note 1 |

Note 1: The relative humidity must not exceed 90% non-condensing at temperatures of 40°C or less. At temperatures greater than 40°C, the wet bulb temperature must not exceed 39°C. When operate at low temperatures, the brightness of CCFL will drop and the lifetime of CCFL will be reduced.

Note 2: The unit should not be exposed to corrosive chemicals.

3. Electrical characteristics
 a. Typical operating conditions

| | Item | Symbol | Min. | Typ. | Max. | Unit | Remark |
|----------------------|---------------------|------------|------|------|------|--------|--------|
| Power supply voltage | Input voltage | V_{CC} | 4.75 | 5.0 | 5.25 | V | |
| | Current consumption | I_A | - | 800 | 1000 | mArms | Note 1 |
| | Inrush current | I_{RUSH} | - | - | 1.5 | mApeak | Note 2 |
| Internal logic | Low voltage | V_{IL} | 0 | - | 1.0 | V | |
| | High voltage | V_{IH} | 2.3 | - | 3.3 | V | |
| Power ripple voltage | | V_{RP} | - | - | 100 | mVp-p | |

Note 1: Effective value (mArms) at $V_{CC} = 5\text{ V}/25^\circ\text{C}$.

Note 2: Refer to the following power-on condition.

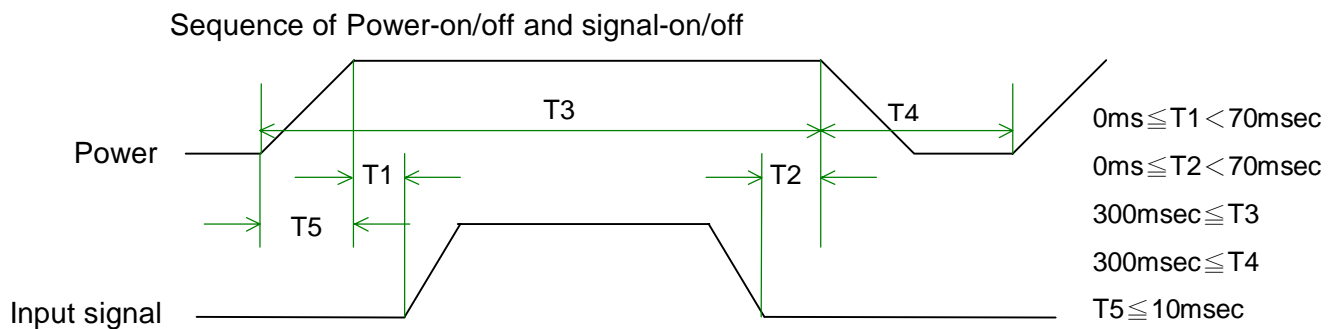
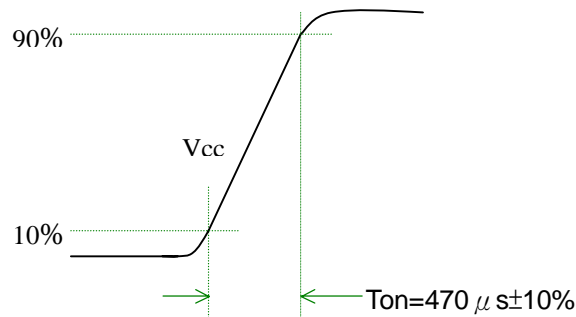

Apply the lamp voltage within the LCD operating range. When the backlight turns on before the LCD operation or the LCD turns off before the backlight turns off, the display may momentarily become abnormal.

Caution

The above on/off sequence should be applied to avoid abnormal function in the display.

In case of handling:

Make sure to turn off the power when you plug the cable into the input connector or pull the cable out of the connector.

b. Display color v.s. input data signals

| Display colors | | Data signal (0 : Low level, 1: High level) | | | | | | | | | | | | | | | | | | | | | | | |
|--------------------------|--------------------------|--|----|----|----|----|----|----|----|----|----|----|----|----|----|----|----|----|----|----|----|----|----|----|----|
| | | R7 | R6 | R5 | R4 | R3 | R2 | R1 | R0 | G7 | G6 | G5 | G4 | G3 | G2 | G1 | G0 | B7 | B6 | B5 | B4 | B3 | B2 | B1 | B0 |
| Basic colors | Black | 0 | 0 | 0 | 0 | 0 | 0 | 0 | 0 | 0 | 0 | 0 | 0 | 0 | 0 | 0 | 0 | 0 | 0 | 0 | 0 | 0 | 0 | 0 | 0 |
| | Blue | 0 | 0 | 0 | 0 | 0 | 0 | 0 | 0 | 0 | 0 | 0 | 0 | 0 | 0 | 0 | 0 | 1 | 1 | 1 | 1 | 1 | 1 | 1 | 1 |
| | Red | 1 | 1 | 1 | 1 | 1 | 1 | 1 | 1 | 0 | 0 | 0 | 0 | 0 | 0 | 0 | 0 | 0 | 0 | 0 | 0 | 0 | 0 | 0 | 0 |
| | Magenta | 1 | 1 | 1 | 1 | 1 | 1 | 1 | 1 | 0 | 0 | 0 | 0 | 0 | 0 | 0 | 0 | 1 | 1 | 1 | 1 | 1 | 1 | 1 | 1 |
| | Green | 0 | 0 | 0 | 0 | 0 | 0 | 0 | 0 | 1 | 1 | 1 | 1 | 1 | 1 | 1 | 1 | 0 | 0 | 0 | 0 | 0 | 0 | 0 | 0 |
| | Cyan | 0 | 0 | 0 | 0 | 0 | 0 | 0 | 0 | 1 | 1 | 1 | 1 | 1 | 1 | 1 | 1 | 1 | 1 | 1 | 1 | 1 | 1 | 1 | 1 |
| | Yellow | 1 | 1 | 1 | 1 | 1 | 1 | 1 | 1 | 1 | 1 | 1 | 1 | 1 | 1 | 1 | 1 | 0 | 0 | 0 | 0 | 0 | 0 | 0 | 0 |
| | White | 1 | 1 | 1 | 1 | 1 | 1 | 1 | 1 | 1 | 1 | 1 | 1 | 1 | 1 | 1 | 1 | 1 | 1 | 1 | 1 | 1 | 1 | 1 | 1 |
| Red grayscale | Black | 0 | 0 | 0 | 0 | 0 | 0 | 0 | 0 | 0 | 0 | 0 | 0 | 0 | 0 | 0 | 0 | 0 | 0 | 0 | 0 | 0 | 0 | 0 | 0 |
| | Dark ↑ ↓ bright | 0 | 0 | 0 | 0 | 0 | 0 | 0 | 1 | 0 | 0 | 0 | 0 | 0 | 0 | 0 | 0 | 0 | 0 | 0 | 0 | 0 | 0 | 0 | 0 |
| | | 0 | 0 | 0 | 0 | 0 | 0 | 1 | 0 | 0 | 0 | 0 | 0 | 0 | 0 | 0 | 0 | 0 | 0 | 0 | 0 | 0 | 0 | 0 | 0 |
| | Red | 1 | 1 | 1 | 1 | 1 | 1 | 0 | 1 | 0 | 0 | 0 | 0 | 0 | 0 | 0 | 0 | 0 | 0 | 0 | 0 | 0 | 0 | 0 | 0 |
| | | 1 | 1 | 1 | 1 | 1 | 1 | 1 | 0 | 0 | 0 | 0 | 0 | 0 | 0 | 0 | 0 | 0 | 0 | 0 | 0 | 0 | 0 | 0 | 0 |
| | Green grayscale | Black | 0 | 0 | 0 | 0 | 0 | 0 | 0 | 0 | 0 | 0 | 0 | 0 | 0 | 0 | 0 | 0 | 0 | 0 | 0 | 0 | 0 | 0 | 0 |
| Dark ↑ ↓ bright | 0 | 0 | 0 | 0 | 0 | 0 | 0 | 0 | 0 | 0 | 0 | 0 | 0 | 0 | 0 | 1 | 0 | 0 | 0 | 0 | 0 | 0 | 0 | 0 | |
| | 0 | 0 | 0 | 0 | 0 | 0 | 0 | 0 | 0 | 0 | 0 | 0 | 0 | 0 | 1 | 0 | 0 | 0 | 0 | 0 | 0 | 0 | 0 | 0 | |
| Green | 0 | 0 | 0 | 0 | 0 | 0 | 0 | 0 | 1 | 1 | 1 | 1 | 1 | 1 | 0 | 1 | 0 | 0 | 0 | 0 | 0 | 0 | 0 | 0 | |
| | 0 | 0 | 0 | 0 | 0 | 0 | 0 | 0 | 1 | 1 | 1 | 1 | 1 | 1 | 1 | 0 | 0 | 0 | 0 | 0 | 0 | 0 | 0 | 0 | |
| Blue grayscale | Black | 0 | 0 | 0 | 0 | 0 | 0 | 0 | 0 | 0 | 0 | 0 | 0 | 0 | 0 | 0 | 0 | 0 | 0 | 0 | 0 | 0 | 0 | 0 | 0 |
| | Dark ↑ ↓ bright | 0 | 0 | 0 | 0 | 0 | 0 | 0 | 0 | 0 | 0 | 0 | 0 | 0 | 0 | 0 | 0 | 0 | 0 | 0 | 0 | 0 | 0 | 0 | 1 |
| | | 0 | 0 | 0 | 0 | 0 | 0 | 0 | 0 | 0 | 0 | 0 | 0 | 0 | 0 | 0 | 0 | 0 | 0 | 0 | 0 | 0 | 0 | 1 | 0 |
| | Blue | 0 | 0 | 0 | 0 | 0 | 0 | 0 | 0 | 0 | 0 | 0 | 0 | 0 | 0 | 0 | 0 | 1 | 1 | 1 | 1 | 1 | 1 | 0 | 1 |
| 0 | | 0 | 0 | 0 | 0 | 0 | 0 | 0 | 0 | 0 | 0 | 0 | 0 | 0 | 0 | 0 | 1 | 1 | 1 | 1 | 1 | 1 | 1 | 0 | |

Note: Each basic color can be displayed in 64 gray scales using the 8 bit data signals. By combining the 24-bit data signals(R, G, B), the 16777216 colors can be achieved on the display.

c. Input signal timing

Timing diagrams of input signal are shown in Fig 2.

(1). Timing characteristics of input signals

DE mode

| Item | Symbol | Min. | Typ. | Max. | Unit | Remark |
|---------------------------|--------|------|------|------|------|--------|
| Clock frequency | Fck | 38 | 40 | 42 | MHz | |
| Horizontal blanking | Thb1 | 235 | 256 | 500 | Clk | |
| Horizontal display period | Thd | - | 800 | - | Clk | |
| Horizontal sync. period | Th | 1035 | 1056 | 1300 | Clk | |
| Vertical frequency | - | 46 | 60 | 76 | Hz | |
| Vertical blanking | Tvb1 | 10 | 28 | 150 | Th | |
| Vertical display width | Tvd | - | 600 | - | Th | |
| Vertical sync. period | Tv | 610 | 628 | 750 | Th | |

H/V mode

| Item | Symbol | Min. | Typ. | Max. | Unit | Remark |
|---------------------------|---------|------|------|---------|------|--------|
| Clock frequency | Fck | 38 | 40 | 42 | MHz | |
| Horizontal display period | Thd | 1030 | 1056 | 1300 | Clk | |
| Hsync pulse width | Thw | 5 | 128 | - | Clk | |
| Hsync front porch | Thf | 10 | 40 | - | Clk | |
| Hsync back porch | Thb | 8 | 88 | - | Clk | |
| Hsync width+back porch | Thw+Thb | 80 | - | Thd-810 | Clk | |
| Hsync blanking | Thb1 | 230 | 256 | 500- | Clk | |
| Vsync period | Tv | 610 | 628 | 650 | Th | |
| Vsync width | Tvw | 2 | 4 | - | Th | |
| Vsync front porch | Tvf | 0 | 1 | - | Th | |
| Vsync blanking | Tvb1 | 10 | 28 | 50 | Th | |
| Hsync/Vsync phase shift | Tvpd | 2 | 320 | - | Clk | |

| Item | Symbol | Value | Unit | Description |
|--------------------------|--------|-------|------|---|
| Horizontal display start | The | 218 | Clk | After falling edge of Hsync, counting 218 clk, then getting valid data from 219th clk's data. |
| Vertical display start | Tve | 25 | Th | After falling edge of Vsync, counting 25 Th, then getting 26th Th's data. |

Note 1:Clock falling edge latch the data.

Note 2:H/V is negative polarity.

d. Display position

| | | | | | | |
|------------|------------|-------|------------|-------|--------------|--------------|
| D(1,1) | D(2,1) | | D(X,1) | | D(799,1) | D(800,1) |
| D(1,2) | D(2,2) | | D(X,2) | | D(799,2) | D(800,2) |
| ⋮ | | | ⋮ | | ⋮ | ⋮ |
| D(1,Y) | D(2,Y) | | D(X,Y) | | D(799,Y) | D(800,Y) |
| ⋮ | | | ⋮ | | ⋮ | ⋮ |
| D(1,599) | D(2,599) | | D(X,599) | | D(799,599) | D(800,599) |
| D(1,600) | D(2,600) | | D(X,600) | | D(799,600) | D(800,600) |

e. Backlight unit

The backlight system is an edge-lighting type with a CCFT(Cold Cathode Fluorescent Tube).

The characteristics of a single lamp are shown in the following tables.

| Parameter | Symbol | Min. | Typ. | Max. | Unit | Remark |
|-----------------------|----------------|-------|-------|--------------|-------|-----------|
| Lamp voltage | V _L | 720 | 800 | 880 | Vrms | Note 1 |
| Lamp current | I _L | 4 | 5.5 | 7 | mArms | Note 1 |
| Power consumption | P _L | - | 4.4x6 | - | W | Note 2 |
| Lamp starting voltage | V _s | - | - | 1500(T=0°C) | Vrms | Note 3 |
| | | - | - | 1150(T=25°C) | | |
| Frequency | F _L | 40 | 52 | 60 | KHz | Note 4 |
| Lamp life time | L _L | 50000 | - | - | Hr | Note 1, 5 |

Note 1: T= 25°C

Note 2: Inverter should be designed with the characteristic of lamp. When you are designing the inverter, the output voltage of the inverter should comply with the following conditions.

- (1). The area under the positive and negative cycles of the waveform of the lamp current and lamp voltage should be area symmetric (the symmetric ratio should be larger than 90%).
- (2). There should not be any spikes in the waveform.
- (3). The waveform should be sine wave as possible.
- (4). Lamp current should not exceed the maximum value within the operating temperature (It is prohibited to over the maximum lamp current even if operated in the non-guaranteed temperature). When lamp current over the maximum value for a long time, it may cause fire. Therefore, it is recommend that the inverter should have the current limited circuit.

Note 3: The inverter open voltage should be designed larger than the lamp starting voltage at T=0°C, otherwise backlight may be blinking for a moment after turning on or not be able to turn on. The open voltage should be measured after ballast capacitor. If an inverter has shutdown function it should keep its open voltage for longer than 1 second even if lamp connector is open.

Note 4: Lamp frequency may produce interference with horizontal synchronous frequency and this may cause line flow on the display. Therefore lamp frequency shall be detached from the horizontal synchronous frequency and its harmonics as far as possible in order to avoid interference.

Note 5: Brightness ($I_L = 6\text{mA}$) to be decrease to the 50% of the initial value.

Note 6: CN2 connector (backlight): BHSR-02VS-1 (JST)

Mating connector: SM02B-BHS-1-TB (JST)

| Pin no. | Symbol | Function | Remark |
|---------|--------|-------------------------|--------------------|
| 1 | H | CCFL power supply(H.V.) | Cable color: Pink |
| 2 | L | CCFL power supply(GND) | Cable color: White |

C. Optical specifications (Note 1, Note 2)

| Item | Symbol | Condition | Specification | | | Unit | Remark |
|---|------------|--------------------|----------------------|------------------|------------------|------|------------|
| | | | Min. | Typ. | Max. | | |
| Response time Rising time Falling time | Tr Tf | $\theta = 0^\circ$ | - - | 6 16 | 10 25 | ms | Note 4 |
| Contrast ratio(center of screen) | CR | $\theta = 0^\circ$ | 400 | 500 | - | | Note 3,5 |
| Viewing angle Top Bottom Left Right | | $CR \geq 5$ | 80 80 80 80 | - - - - | - - - - | deg. | Note 3,5,7 |
| Brightness(center of screen) | Y_L | $\theta = 0^\circ$ | 400 | 500 | - | nit | Note 3,6 |
| Color chromaticity(CIE) | Wx | $\theta = 0^\circ$ | 0.25 | 0.28 | 0.31 | | Note 3 |
| | Wy | | 0.27 | 0.30 | 0.33 | | |
| | Rx | | | | | | |
| | Ry | | | | | | |
| | Gx | | | | | | |
| | Gy | | | | | | |
| | Bx | | | | | | |
| | By | | | | | | |
| White uniformity | δ_w | | 70 | - | - | % | Note 3,8 |

Note 1: Ambient temperature = 25°C.

Note 2: To be measured in dark room after backlight warm up 30 minutes.

Note 3: To be measured with a viewing cone of 1° by Topcon luminance meter BM-5A.

Note 4: Definition of response time:

The output signals of BM-7 are measured when the input signals are changed from "Black" to "White" (falling time) and from "White" to "Black" (rising time), respectively. The response time interval between the 10% and 90% of amplitudes. Refer to figure as below.

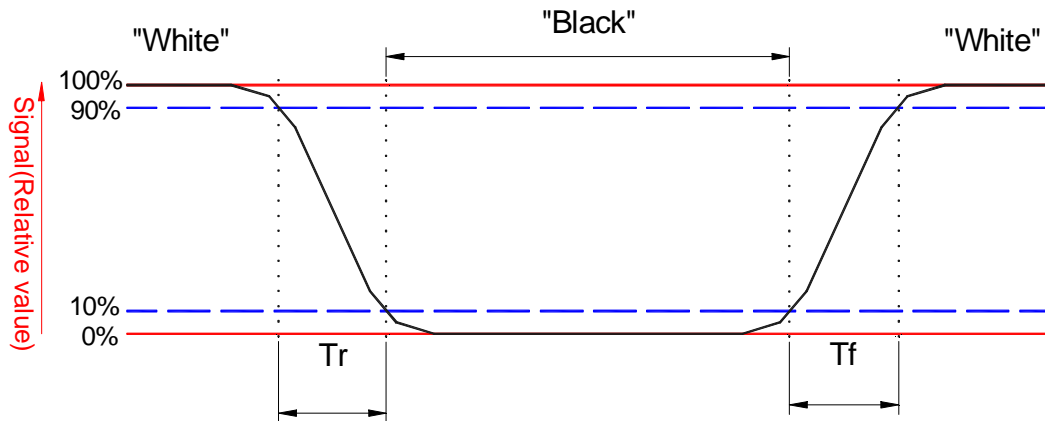

Note 5. Definition of contrast ratio:

Contrast ratio is calculated with the following formula.

$$\text{Contrast ratio (CR)} = \frac{\text{Brightness on the "white" state}}{\text{Brightness on the "black" state}}$$

Note 6: Driving conditions for CCFL: $I_L = 5.5 \text{ mA}$, 52KHz Frequency.

Note 7: Definition of viewing angle:

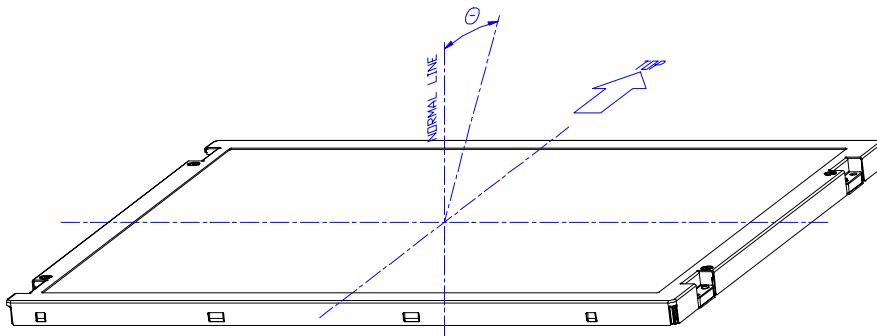

Note 8: Definition of white uniformity:

White uniformity is calculated with the following formula.

Luminance are measured at the following nine points (1~9).

$$\delta_w = \frac{\text{Minimum Brightness of nine points}}{\text{Maximum Brightness of nine points}}$$

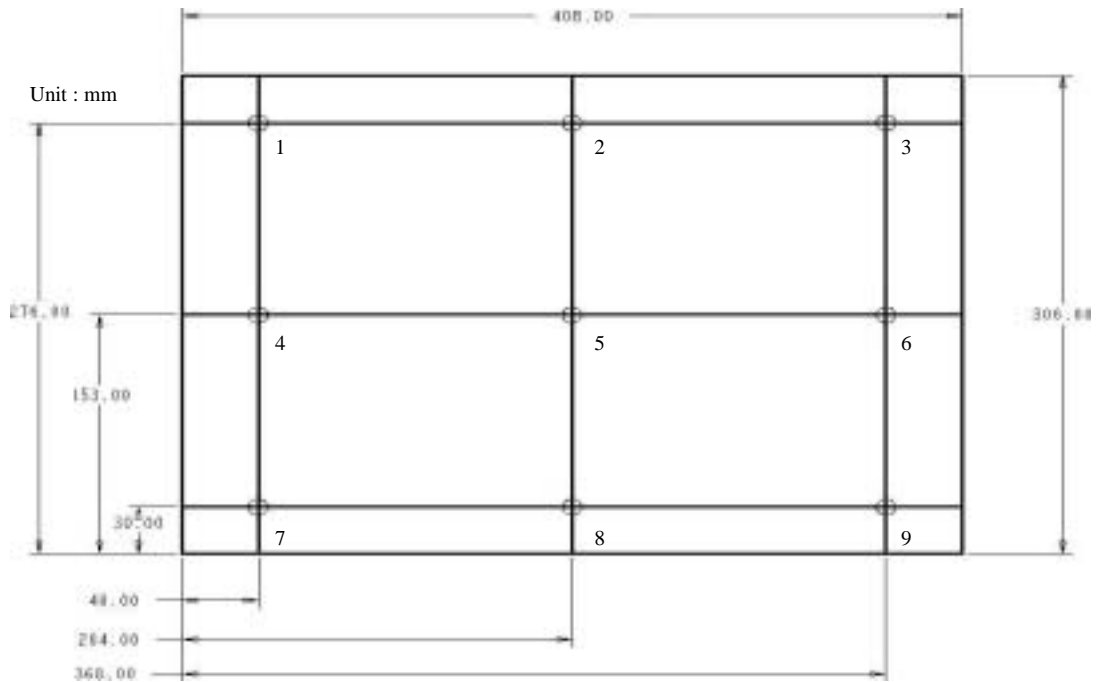

D. Reliability test items (Note 1)

| Test tem | Test Condition | Remark |
|--|--|--------------|
| High temperature storage | 60°C, 240Hrs | Note 1, 2, 3 |
| Low temperature storage | -20°C, 240Hrs | Note 1, 2, 3 |
| High temperature & high humidity operation | 40°C, 90%RH, 240Hrs (No condensation) | Note 1, 2, 3 |
| High temperature operation | 50°C, 240Hrs | Note 1, 2, 3 |
| Low temperature operation | 0°C, 240Hrs | Note 1, 2, 3 |
| Temperature cycling (non-operation) | -20°C ~60°C 1H, 10mins, 1H, 5cycles | Note 1, 2, 3 |
| Electrostatic discharge (non-operation) | 150 pF, 150Ω, 10kV, 1 second, 9 position on the panel, 10 times each place | Note 3 |
| Vibration (non-operation) | Sweep: 1G, 10Hz ~ 500Hz ~ 10Hz / 2.5min 2 hours for each direction X, Y, Z (6 Hrs in total) | Note 1, 2, 3 |
| Mechanical shock (non-operation) | 50G/11ms, 200G/2ms, ±X, ±Y, ±Z once for each direction | Note 1, 2, 3 |

Note 1: Evaluation should be tested after storage at room temperature for one hour.

Note 2: There should be no change which might affect the practical display function when the display quality test is conducted under normal operating condition.

Note 3: Judgement: 1. Function OK.

2. No serious image quality degradation.

E. Display quality

The display quality of the color TFT-LCD module should be in compliance with the AUO's OQC inspection standard.

F. Handling precaution

The Handling of the TFT-LCD should be in compliance with the AUO's handling principle standard.

G. Packing form:

TBD

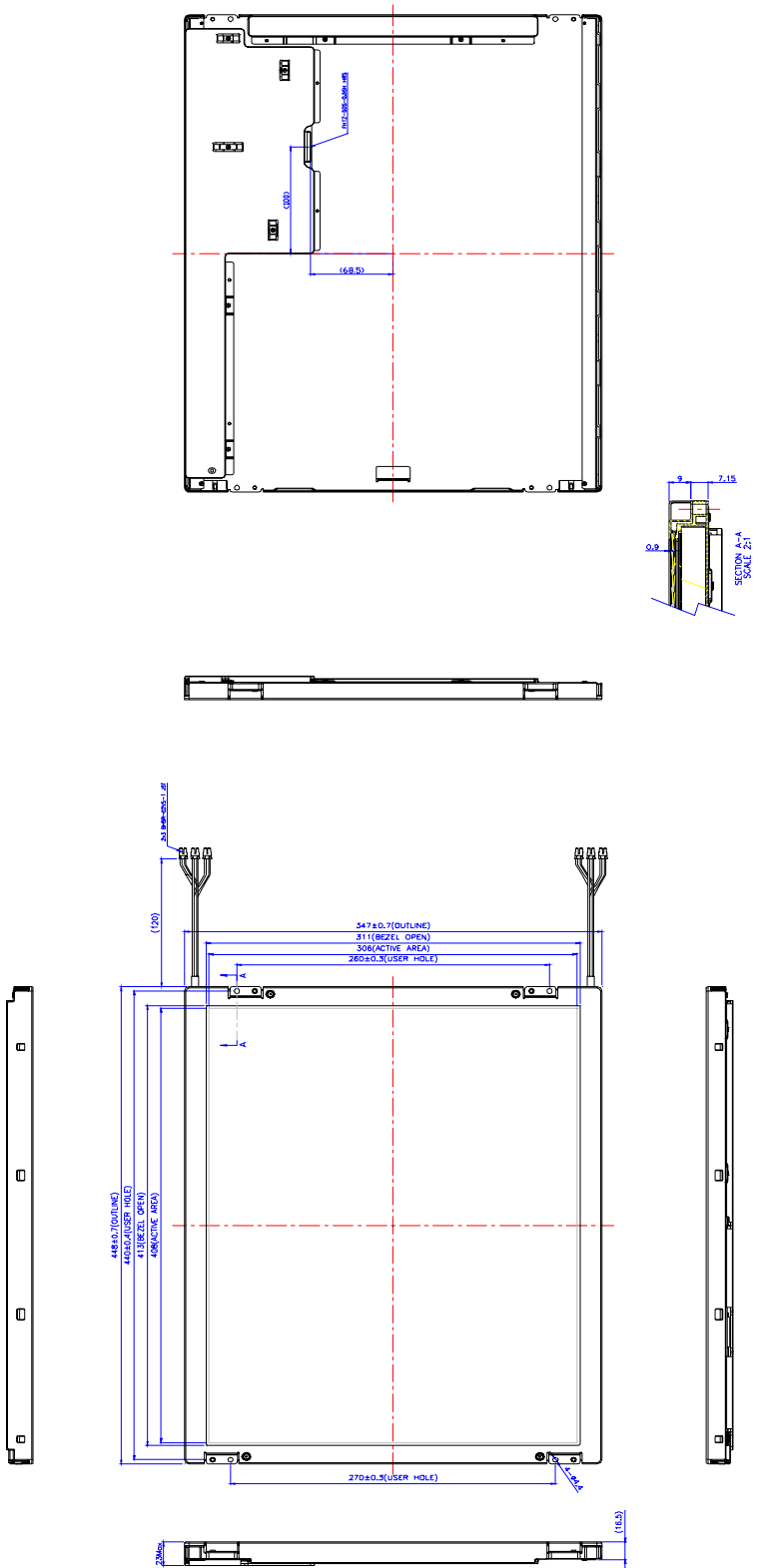

Fig.1 LCM outline dimension

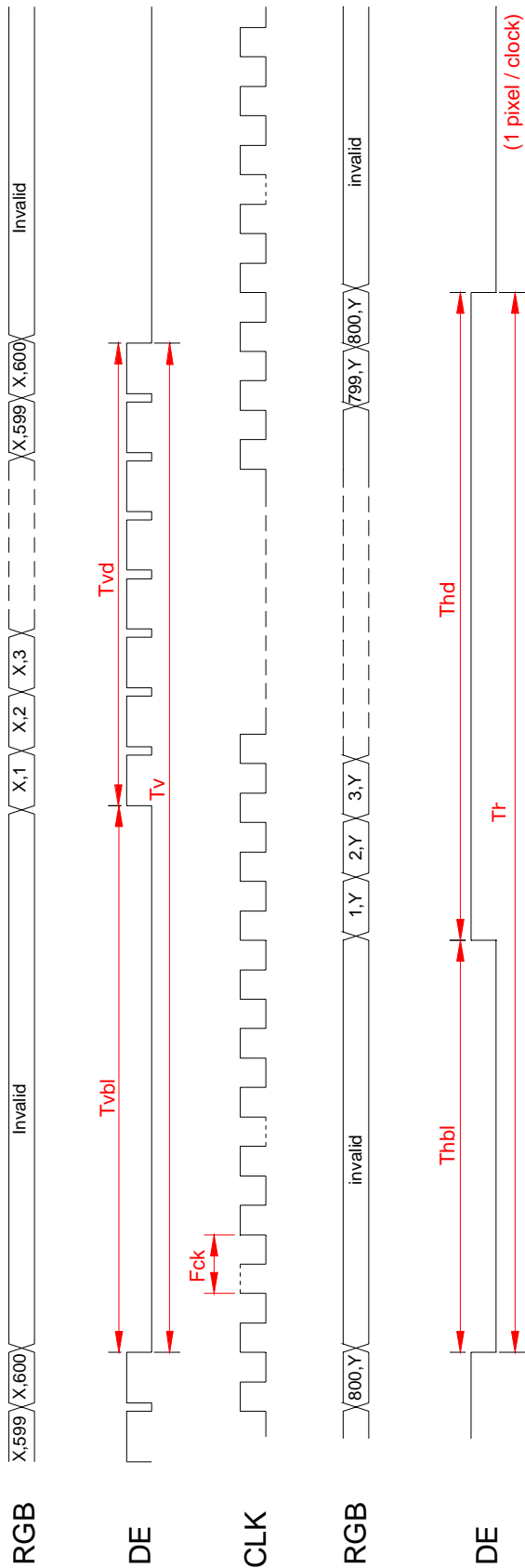

Fig.2 Timing chart