

## Quad SPST CMOS Analog Switches

### FEATURES

- Low On-Resistance: 50  $\Omega$
- Low Leakage: 80 pA
- Low Power Consumption: 22 nW
- Fast Switching Action— $t_{ON}$ : 120 ns
- Low Charge Injection
- DG211/DG212 Upgrades
- TTL/CMOS Logic Compatible

### BENEFITS

- Low Signal Errors and Distortion
- Reduced Power Supply Requirements
- Faster Throughput
- Improved Reliability
- Reduced Pedestal Errors
- Simple Interfacing

### APPLICATIONS

- Audio Switching
- Battery Powered Systems
- Data Acquisition
- Sample-and-Hold Circuits
- Telecommunication Systems
- Automatic Test Equipment
- Single Supply Circuits
- Hard Disk Drives

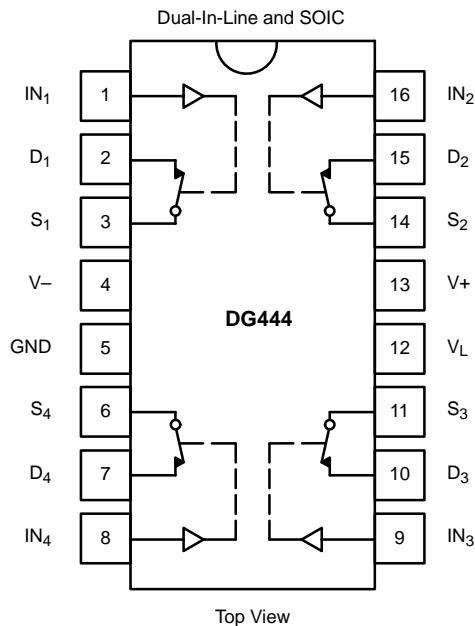
### DESCRIPTION

The DG444/DG445 monolithic quad analog switches are designed to provide high speed, low error switching of analog signals. The DG444 has a normally closed function. The DG445 has a normally open function. Combining low power (22 nW, typ) with high speed ( $t_{ON}$ : 120 ns, typ), the DG444/DG445 are ideally suited for upgrading DG211/212 sockets. Charge injection has been minimized on the drain for use in sample-and-hold circuits.

To achieve high-voltage ratings and superior switching performance, the DG444/DG445 are built on Vishay Siliconix's high-voltage silicon-gate process. An epitaxial layer prevents latchup.

Each switch conducts equally well in both directions when on, and blocks input voltages to the supply levels when off.

### FUNCTIONAL BLOCK DIAGRAM AND PIN CONFIGURATION



TRUTH TABLE		
Logic	DG444	DG445
0	ON	OFF
1	OFF	ON

Logic "0"  $\leq$  0.8 V  
Logic "1"  $\geq$  2.4 V

ORDERING INFORMATION		
Temp Range	Package	Part Number
-40°C to 85°C	16-Pin Plastic DIP	DG444DJ
		DG445DJ
	16-Pin Narrow SOIC	DG444DY
		DG445DY



### ABSOLUTE MAXIMUM RATINGS

V+ to V-	44 V
GND to V-	25 V
V <sub>L</sub>	(GND -0.3 V) to (V+) + 0.3 V
Digital Inputs <sup>a</sup> V <sub>S</sub> , V <sub>D</sub>	(V-) -2 V to (V+) +2 V or 30 mA, whichever occurs first
Continuous Current (Any Terminal)	30 mA
Current, S or D (Pulsed 1 ms, 10% duty cycle)	100 mA
Storage Temperature	-65 to 125°C

Power Dissipation (Package) <sup>b</sup>	
16-Pin Plastic DIP <sup>c</sup>	450 mW
16-Pin Narrow Body SOIC <sup>d</sup>	640 mW

Notes:

- Signals on S<sub>X</sub>, D<sub>X</sub>, or IN<sub>X</sub> exceeding V+ or V- will be clamped by internal diodes. Limit forward diode current to maximum current ratings.
- All leads welded or soldered to PC Board.
- Derate 6 mW/°C above 75°C
- Derate 8 mW/°C above 75°C

SPECIFICATIONS FOR DUAL SUPPLIES									
Parameter	Symbol	Test Conditions Unless Otherwise Specified V+ = 15 V, V- = -15 V V <sub>L</sub> = 5 V, V <sub>IN</sub> = 2.4 V, 0.8 V <sup>e</sup>	Temp <sup>a</sup>	D Suffix -40 to 85°C			Unit		
				Min <sup>b</sup>	Typ <sup>c</sup>	Max <sup>b</sup>			
<b>Analog Switch</b>									
Analog Signal Range <sup>d</sup>	V <sub>ANALOG</sub>		Full	-15		15	V		
Drain-Source On-Resistance	r <sub>DS(on)</sub>	I <sub>S</sub> = -10 mA, V <sub>D</sub> = ±8.5 V V+ = 13.5 V, V- = -13.5 V	Room Full		50	85 100	Ω		
Switch Off Leakage Current	I <sub>S(off)</sub>	V+ = 16.5 V, V- = -16.5 V V <sub>D</sub> = ±15.5 V, V <sub>S</sub> = ∓15.5 V	Room Full	-0.5 -5	±0.01	0.5 5	nA		
	I <sub>D(off)</sub>		Room Full	-0.5 -5	±0.01	0.5 5			
Channel On Leakage Current	I <sub>D(on)</sub>	V+ = 16.5 V, V- = -16.5 V V <sub>S</sub> = V <sub>D</sub> = ±15.5 V	Room Full	-0.5 -10	±0.08	0.5 10			
<b>Digital Control</b>									
Input Current V <sub>IN</sub> Low	I <sub>IL</sub>	V <sub>IN</sub> under test = 0.8 V All Other = 2.4 V	Full	-500	-0.01	500	nA		
Input Current V <sub>IN</sub> High	I <sub>IH</sub>	V <sub>IN</sub> under test = 2.4 V All Other = 0.8 V	Full	-500	0.01	500			
<b>Dynamic Characteristics</b>									
Turn-On Time	t <sub>ON</sub>	R <sub>L</sub> = 1 kΩ, C <sub>L</sub> = 35 pF V <sub>S</sub> = ±10 V, See Figure 2	Room			120	250	ns	
Turn-Off Time	t <sub>OFF</sub>		DG444	Room			110		140
			DG445	Room			160		210
Charge Injection <sup>e</sup>	Q	C <sub>L</sub> = 1 nF, V <sub>S</sub> = 0 V V <sub>gen</sub> = 0 V, R <sub>gen</sub> = 0 Ω	Room			-1		pC	
Off Isolation <sup>e</sup>	OIRR	R <sub>L</sub> = 50 Ω, C <sub>L</sub> = 5 pF, f = 1 MHz	Room			60		dB	
Crosstalk (Channel-to-Channel) <sup>d</sup>	X <sub>TALK</sub>		Room			100			
Source Off Capacitance	C <sub>S(off)</sub>	f = 1 MHz	Room			4		pF	
Drain Off Capacitance	C <sub>D(off)</sub>		Room			4			
Channel On Capacitance	C <sub>D(on)</sub>		V <sub>ANALOG</sub> = 0 V	Room			16		
<b>Power Supplies</b>									
Positive Supply Current	I+	V+ = 16.5 V, V- = -16.5 V V <sub>IN</sub> = 0 or 5 V	Room Full			0.001	1 5	μA	
Negative Supply Current	I-		Room Full	-1 -5		-0.0001			
Logic Supply Current	I <sub>L</sub>		Room Full			0.001	1 5		
Ground Current	I <sub>GND</sub>		Room Full	-1 -5		-0.001			

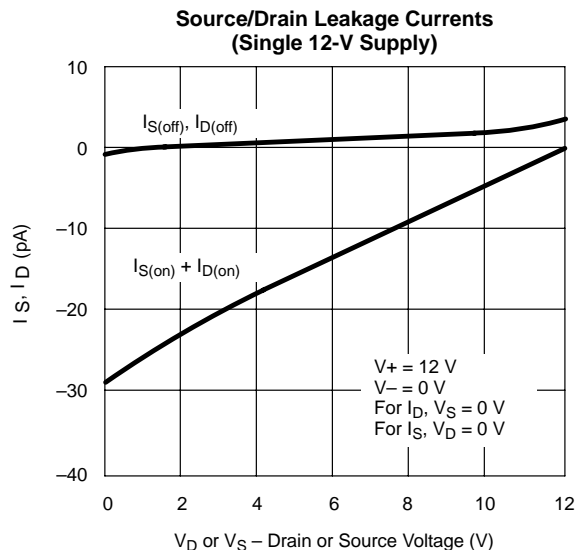
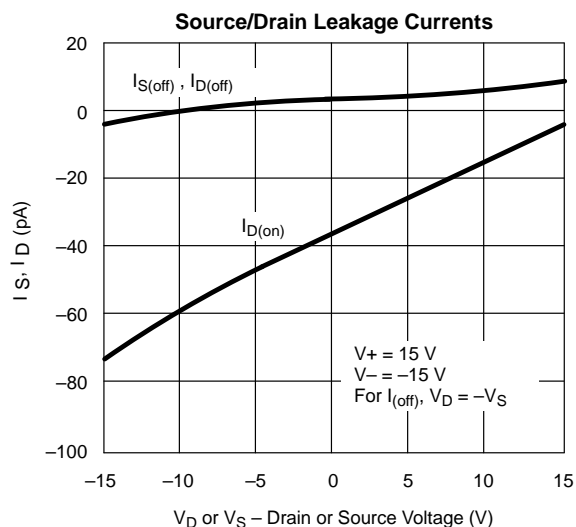
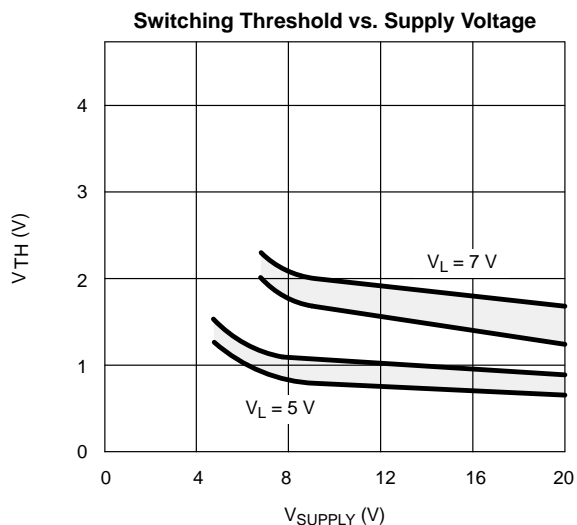
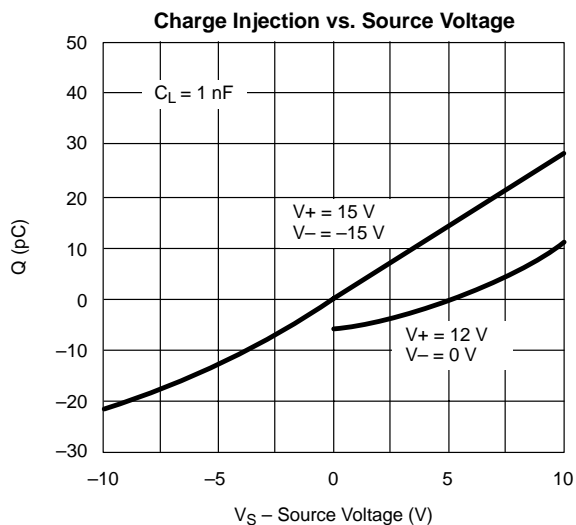
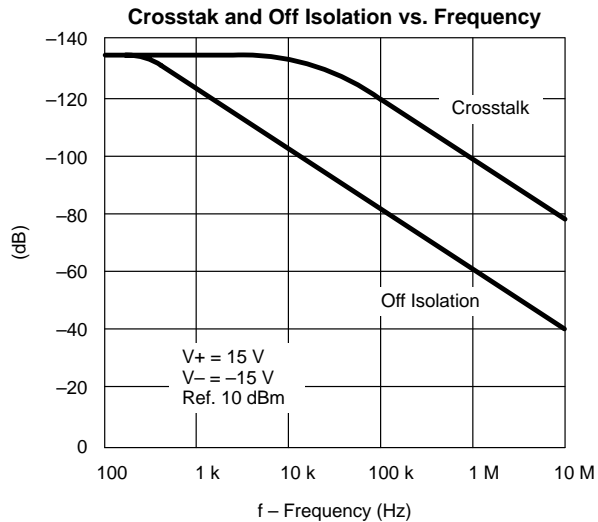
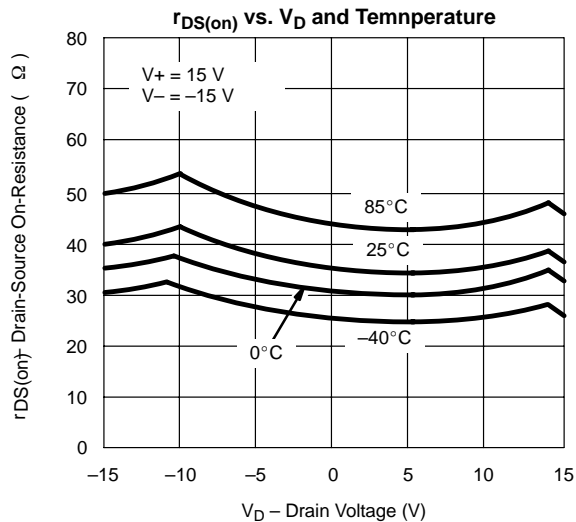


<b>SPECIFICATIONS FOR UNIPOLAR SUPPLIES</b>							
Parameter	Symbol	Test Conditions Unless Otherwise Specified $V_+ = 12\text{ V}, V_- = 0\text{ V}$ $V_L = 5\text{ V}, V_{IN} = 2.4\text{ V}, 0.8\text{ V}^e$	Temp <sup>a</sup>	D Suffix -40 to 85°C			Unit
				Min <sup>b</sup>	Typ <sup>c</sup>	Max <sup>b</sup>	
<b>Analog Switch</b>							
Analog Signal Range <sup>d</sup>	$V_{ANALOG}$		Full	0		12	V
Drain-Source On-Resistance <sup>d</sup>	$r_{DS(on)}$	$I_S = -10\text{ mA}, V_D = 3\text{ V}, 8\text{ V}$ $V_+ = 10.8\text{ V}, V_L = 5.25\text{ V}$	Room Full		100	160 200	$\Omega$
<b>Dynamic Characteristics</b>							
Turn-On Time	$t_{ON}$	$R_L = 1\text{ k}\Omega, C_L = 35\text{ pF}, V_S = 8\text{ V}$ See Figure 2	Room		300	450	ns
Turn-Off Time	$t_{OFF}$		Room		60	200	
Charge Injection	Q	$C_L = 1\text{ nF}, V_{gen} = 6\text{ V}, R_{gen} = 0\ \Omega$	Room		2		pC
<b>Power Supplies</b>							
Positive Supply Current	$I_+$	$V_+ = 13.2\text{ V}, V_{IN} = 0\text{ or }5\text{ V}$	Room Full		0.001	1 5	$\mu\text{A}$
Negative Supply Current	$I_-$	$V_{IN} = 0\text{ or }5\text{ V}$	Room Full	-1 -5	-0.0001		
Logic Supply Current	$I_L$	$V_L = 5.25\text{ V}, V_{IN} = 0\text{ or }5\text{ V}$	Room Full		0.001	1 5	
Ground Current	$I_{GND}$	$V_{IN} = 0\text{ or }5\text{ V}$	Room Full	-1 -5	-0.001		

Notes:

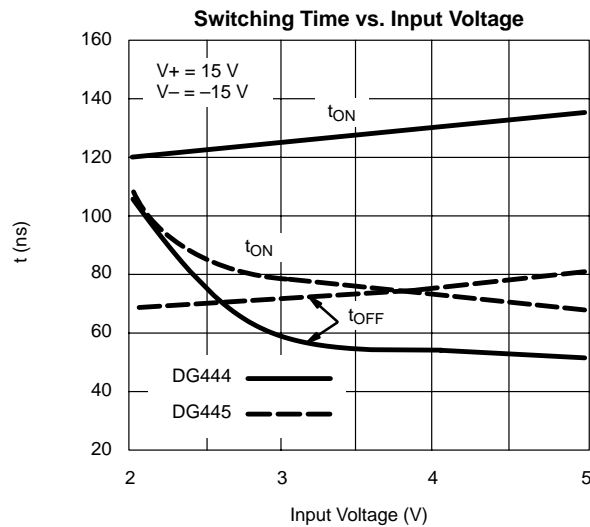
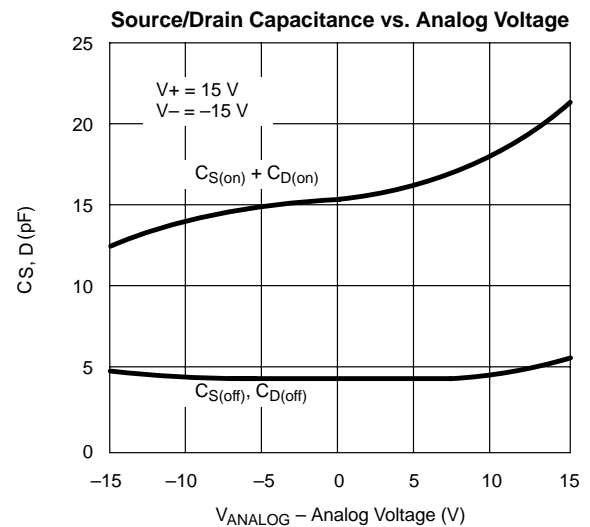
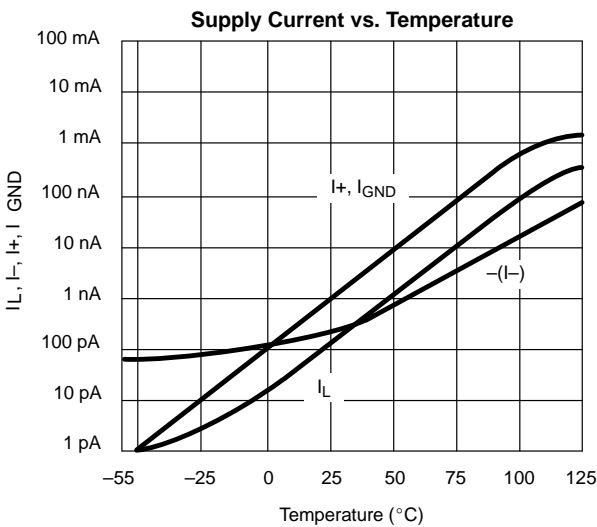
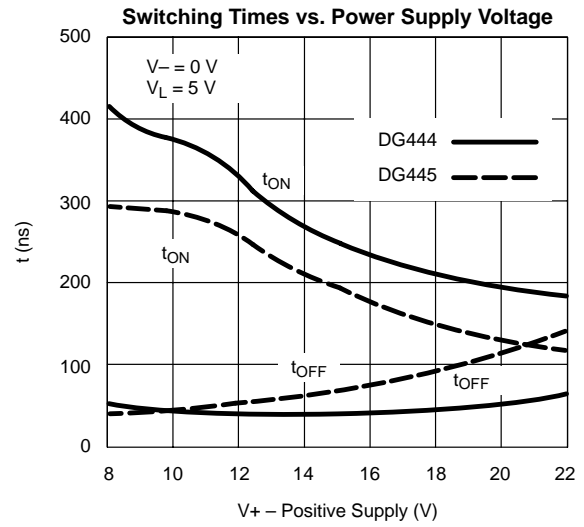
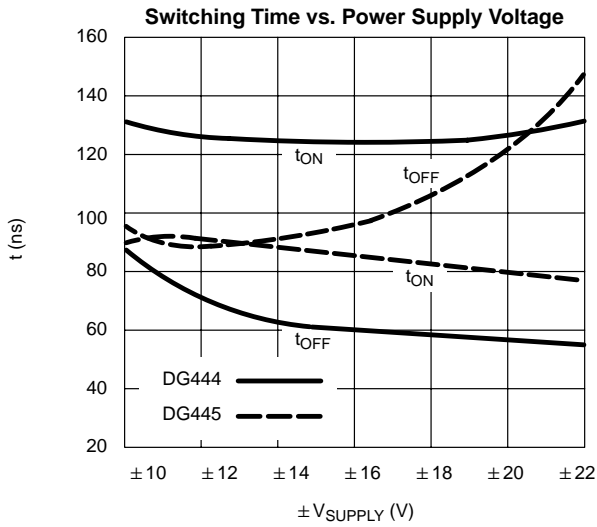
- a. Room = 25°C, Full = as determined by the operating temperature suffix.
- b. The algebraic convention whereby the most negative value is a minimum and the most positive a maximum, is used in this data sheet.
- c. Typical values are for DESIGN AID ONLY, not guaranteed nor subject to production testing.
- d. Guaranteed by design, not subject to production test.
- e.  $V_{IN}$  = input voltage to perform proper function.

**TYPICAL CHARACTERISTICS (25°C UNLESS NOTED)**





**TYPICAL CHARACTERISTICS (25°C UNLESS NOTED)**



**SCHEMATIC DIAGRAM (TYPICAL CHANNEL)**

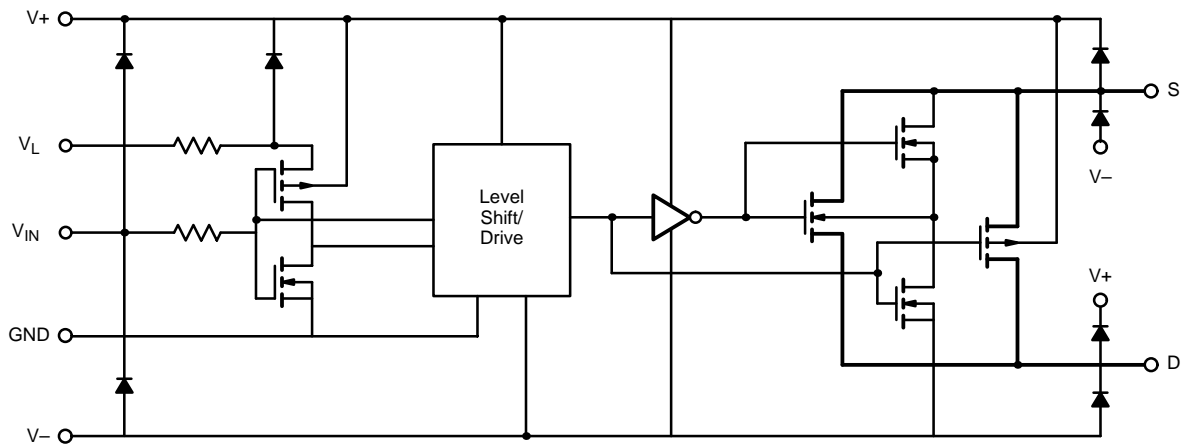
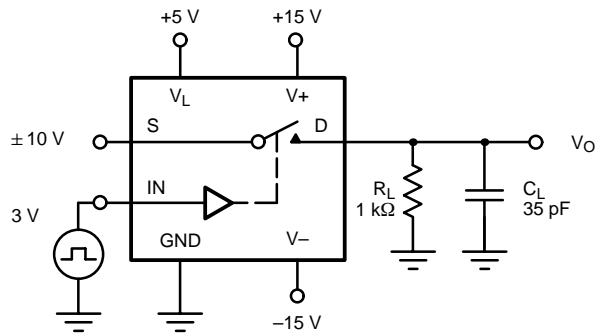
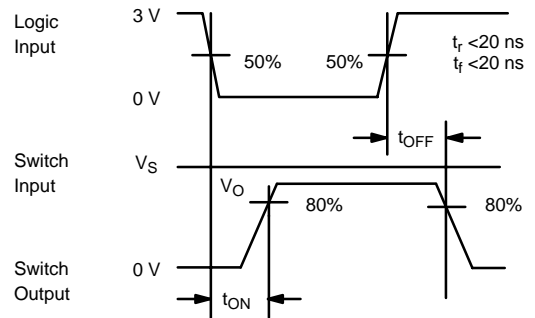


FIGURE 1.

**TEST CIRCUITS**



$C_L$  (includes fixture and stray capacitance)



Note: Logic input waveform is inverted for DG445.

FIGURE 2. Switching Time

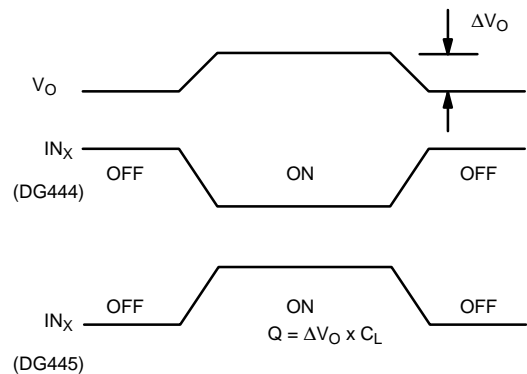
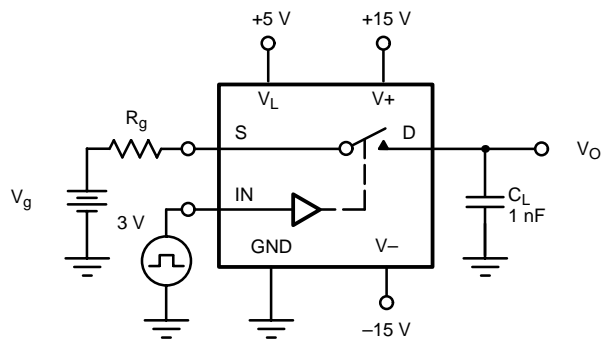
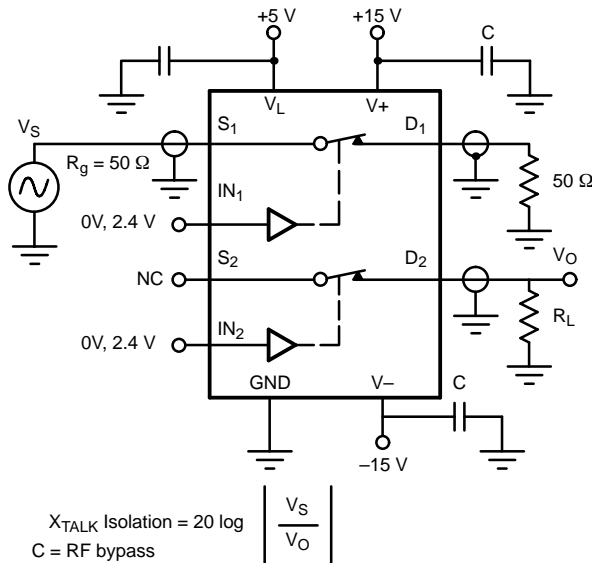


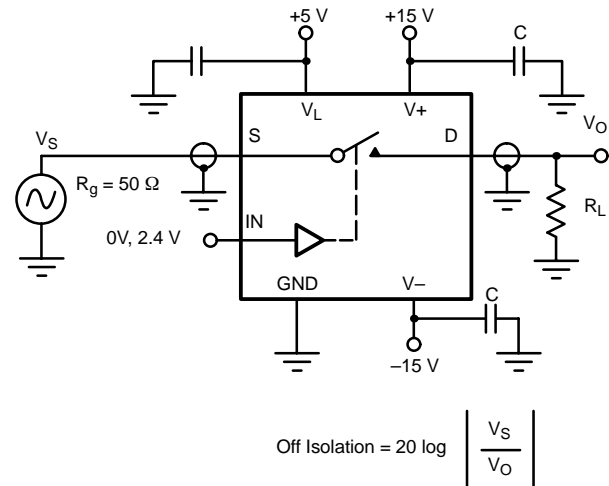
FIGURE 3. Charge Injection

**TEST CIRCUITS**

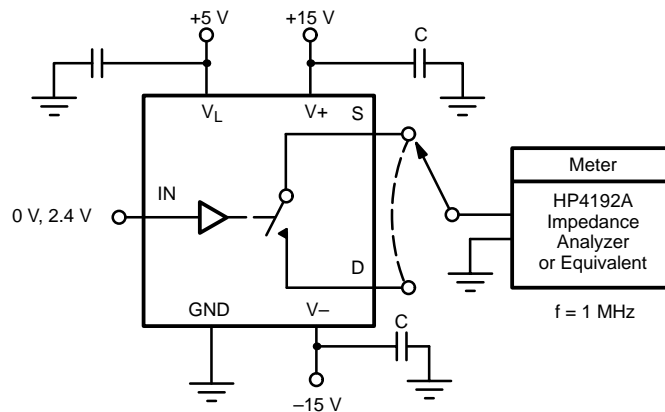
C = 1 mF tantalum in parallel with 0.01 mF ceramic



**FIGURE 4.** Crosstalk

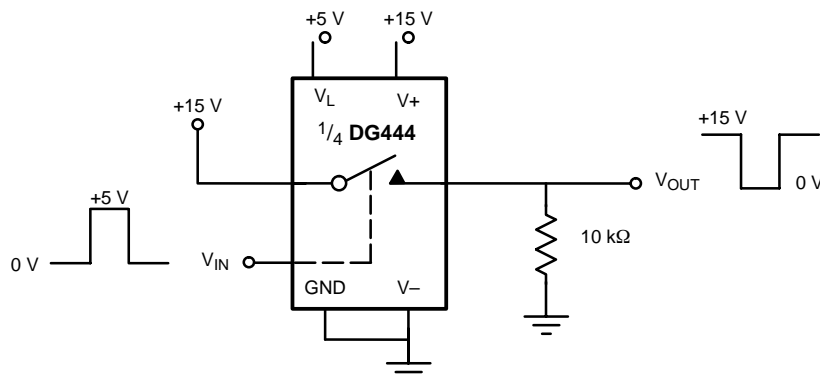


**FIGURE 5.** Off Isolation



**FIGURE 6.** Source/Drain Capacitances

**APPLICATIONS**



**FIGURE 7.** Level Shifter

**APPLICATIONS**

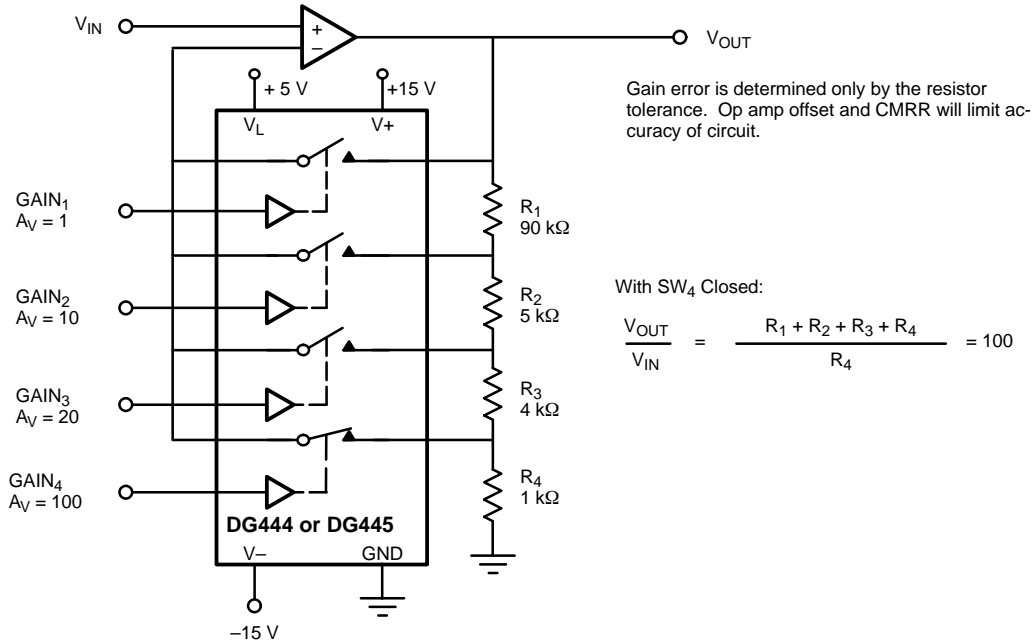


FIGURE 8. Precision-Weighted Resistor Programmable-Gain Amplifier

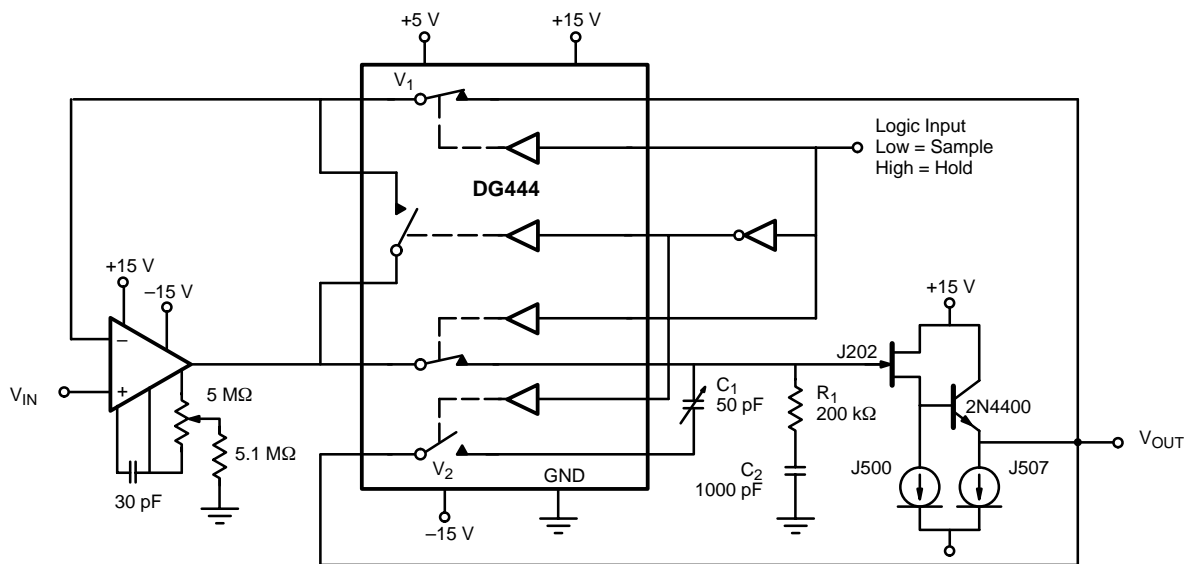


FIGURE 9. Precision Sample-and-Hold