

1599 Series

Plastic Hand Held Cases

722-947 to 723-022

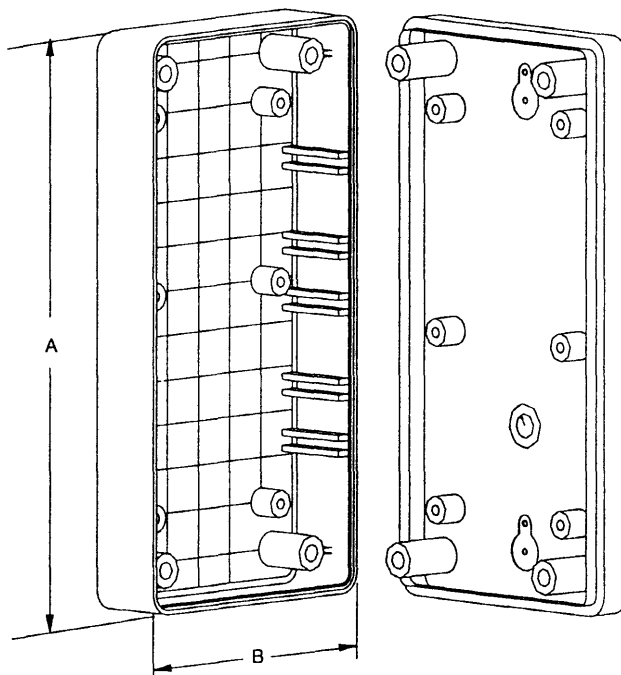
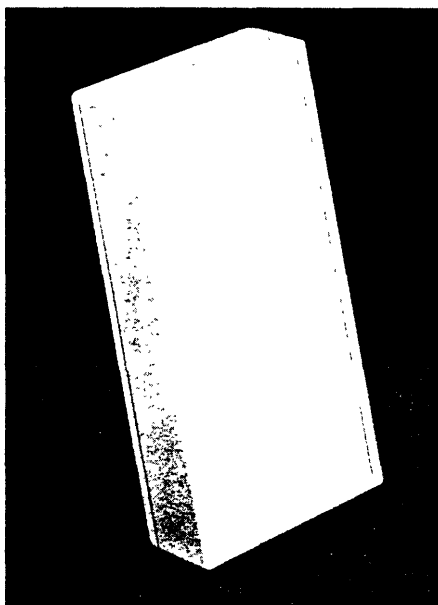

Application

- Attractively styled and ergonomically designed for use as a "hand-held" instrument enclosure.

Construction

- Two piece lap joint construction provides protection against dust accumulation and splashing water.
- Also provides an improved surface for EMI/RFI shielding.
- Extra deep top and ultra shallow base are specifically designed to enhance the aesthetics of the enclosure and provide the user with flexibility and assembly efficiency.
- Interlocking flange on lid.
- Designed to meet IP54.
- Recessed top panel ideal for membrane display.
- Two keyhole knockouts are molded into the inside of the base to facilitate wall mounting installation.
- Six P.C. card mounting bosses are molded into both the top and base to enable horizontal mounting using self tapping screws.
- Integral vertical card guides accept 1.5 mm (0.062") P.C. cards or may be used to insert internal dividing panels to separate the electronics from the batteries

Flame Retardant ABS Version

- Medium impact flame retardant ABS carries a UL flammability rating of 94 V-O at 1.47 mm thickness and a continuous use temperature rating of 60°C.
- Countersunk lid is secured with four machine screws threaded into tapped integral brass bushings.
- Stocked in black and grey.
- EMI/RFI shielded cases are stocked in black.

High Impact Polystyrene Version

- High impact polystyrene plastic.
- Countersunk lid is secured with four self tapping head screws.
- Stocked in grey.

Accessories

Interior battery compartment dividers

- See table.

Accessory screws

- For all cases - 1598ATS100 - Pkg. of 100 #6 x 1/4" self tapping screws for mounting bosses

Replacement Screws - ABS cases

- For 1599B - 1594MS100 - Pkg. of 100 M3 x .5 x 18 mm machine screws
- For 1599E - 1594WMS100 - Pkg. of 100 M3 x .5 x 25 mm machine screws
- For 1599H - 1599HMS100 - Pkg. of 100 M3 x .5 x 28 mm machine screws

Replacement Screws - styrene cases

- For 1599BS - 1599BTS100 - Pkg. of 100 #4 x 3/4" self tapping screws
- For 1599ES - 1594TS100 - Pkg. of 100 #4 x 1" self tapping screws
- For 1599HS - 1599HTS100 - Pkg. of 100 #4 x 1-5/16" self tapping screws

Belt or Pocket Clip

- Available in black.
- Easy to install with 2 screws (supplied).
- Part No. 1599CLIP

Modifications

- Hole punching and machining
- Silk screening
- Bulk packaging
- EMI/RFI shielding
- Custom colors

1599 Series

Plastic Hand Held Cases

Lid Detail

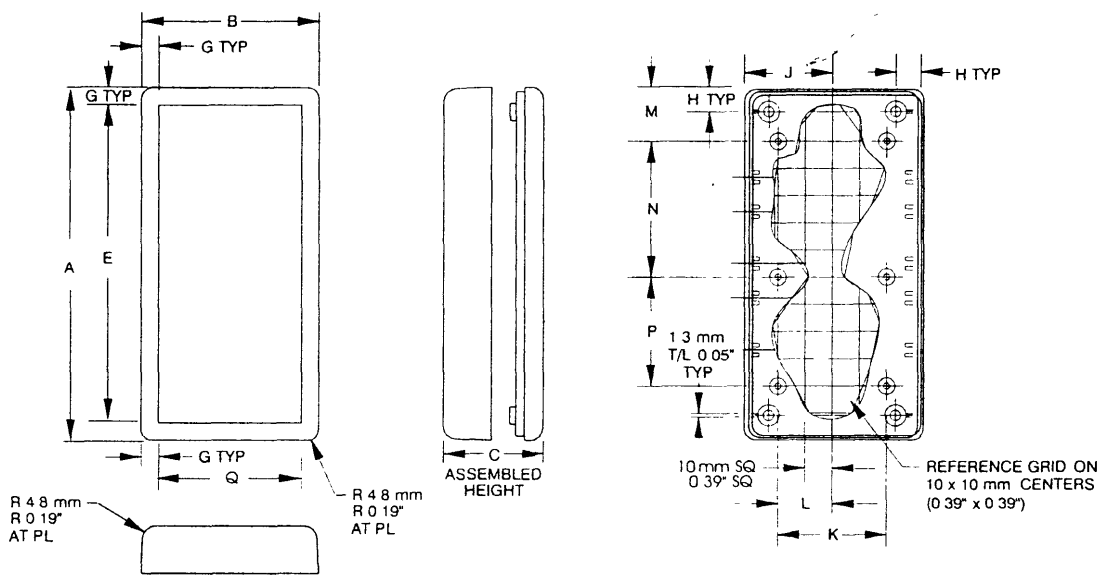

Base Detail

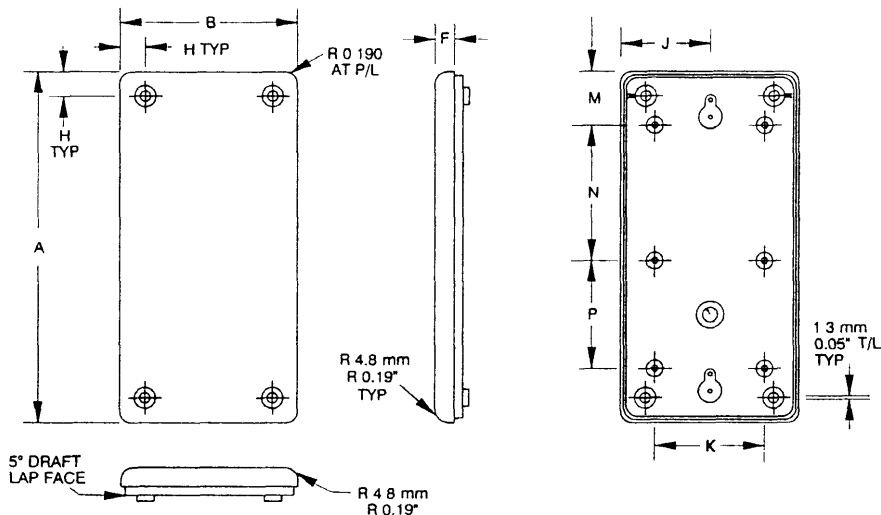

| PART No. | POLY | SHIELDED | UNITS | A | B | C | D | F | G | Q | E | BATTERY DIVIDERS | |
|----------|----------|----------|-------|------|------|------|------|----|-----|------|-------|------------------|-----------|
| | | | | | | | | | | | | FR-ABS | FR-ABS |
| 1599B"_" | 1599BSGY | 1599RBBK | mm | 130 | 65 | 25 | 17.5 | 7 | 6.4 | 52.2 | 117.2 | 1599BD5 | 1599BD100 |
| | | | inch | 5.12 | 2.56 | 0.98 | 0.69 | 28 | 25 | 2.06 | 4.62 | | |
| 1599E"_" | 1599ESGY | 1599REBK | mm | 170 | 85 | 35 | 26 | 8 | 7 | 71 | 156 | 1599ED5 | 1599ED100 |
| | | | inch | 6.70 | 3.35 | 1.38 | 1.03 | 32 | 27 | 2.81 | 6.16 | | |
| 1599H"_" | 1599HSGY | 1599RHBK | mm | 220 | 110 | 45 | 35 | 9 | 7.6 | 94.8 | 204.8 | 1599HD5 | 1599HD100 |
| | | | inch | 8.66 | 4.33 | 1.77 | 1.38 | 36 | 30 | 3.73 | 8.06 | | |

"_" When ordering specify color with suffixes BG (beige), BK (black), BU (blue), GY (grey)
 Note: Inches are for reference only and are not exact Use metric for precise measurements

NOTES

INTERNAL: -ABS CASE VD WITH BRASS INSERTS &
-M SCREWS
-STRONG SOL TAPPING SCREWS.

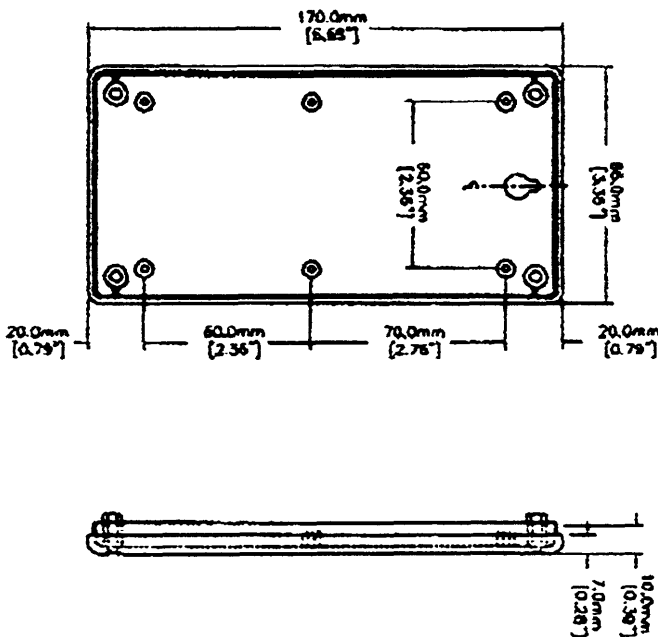
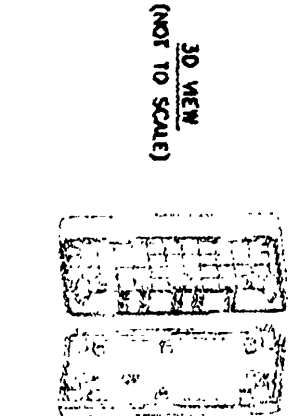
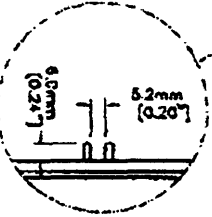
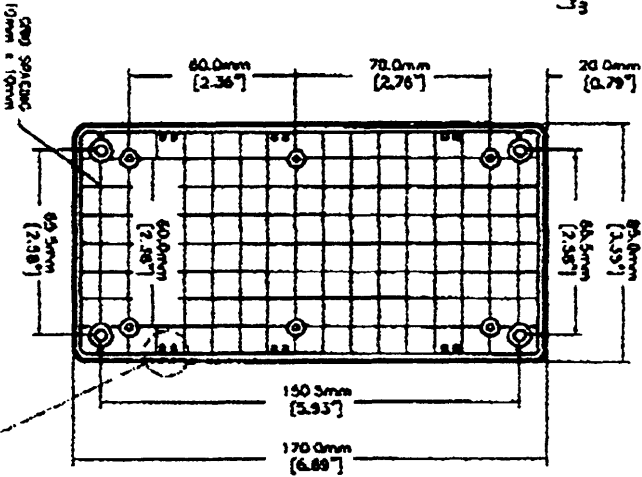
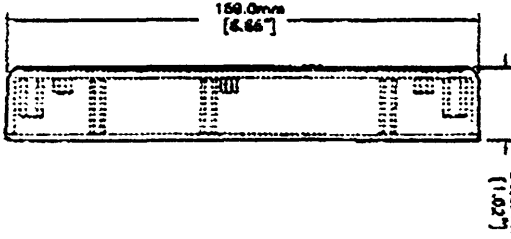
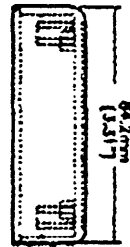

VIEW INSIDE LID

VIEW OF BOX (LID REMOVED)



HAMMOND MANUFACTURING

1599E

SHEET 1 OF 2

CANADA - PH (519) 886 7170 - FAX (519) 886 8311
U.S.A. - PH (716) 631 5700 - FAX (716) 631 1156

NOTES

MATERIAL: -ABS UL94 V0 WITH BRASS INSERTS & M3 SCREWS.
 -STYRENE SELF TAPPING SCREWS.

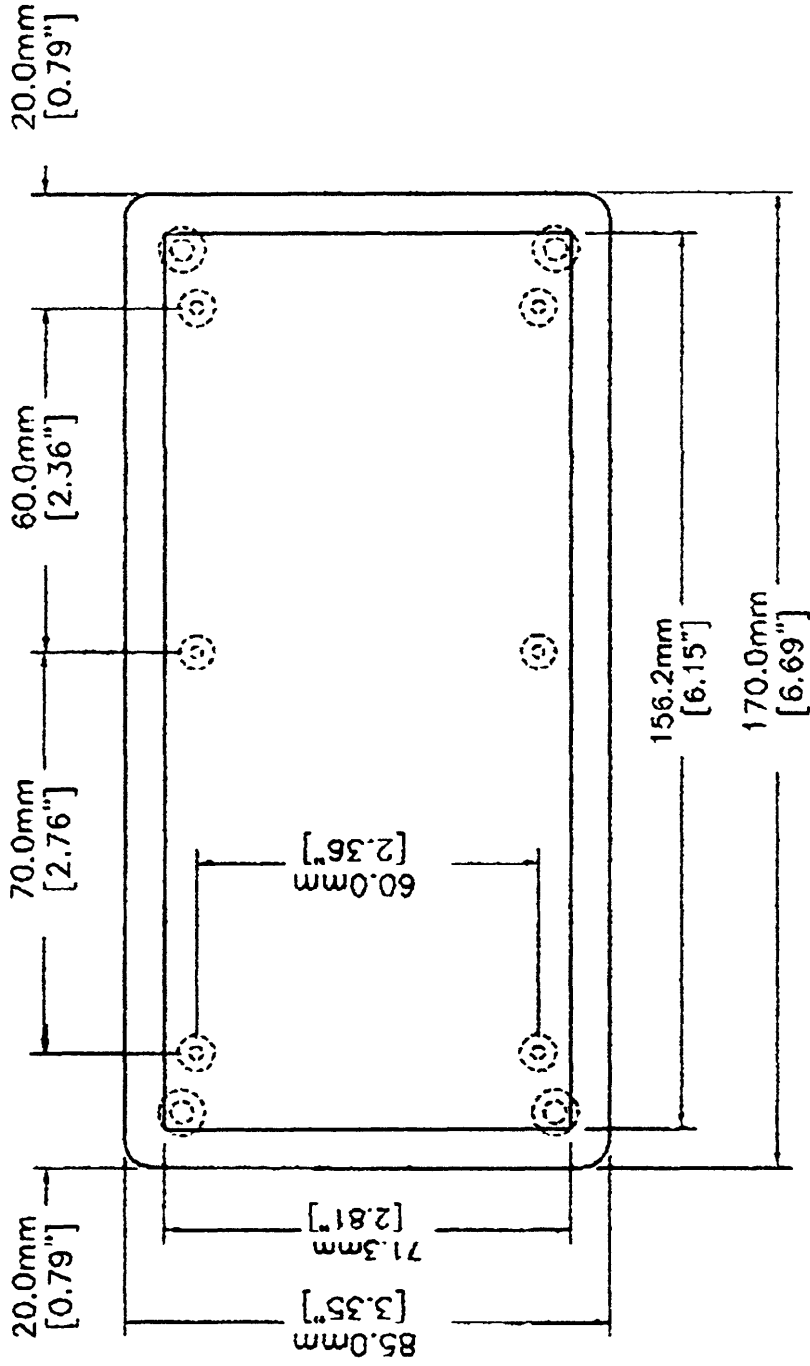

VIEW OF MODIFIABLE FACE

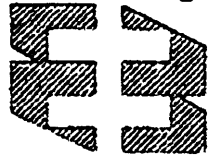

HAMMOND MANUFACTURING

1599E

SHEET 1 OF 2

CANADA - PH (519) 886 7170 - FAX (519) 886 8311
 U.S.A. - PH (716) 631 5700 - FAX (716) 631 1156