

THESE DRAWINGS ARE THE PROPERTY OF QUALTEK ELECTRONICS AND NOT TO BE REPRODUCED FOR OR COMMUNICATED TO A THIRD PARTY WITHOUT THE EXPRESS WRITTEN PERMISSION OF AN OFFICER OF QUALTEK ELECTRONICS.

REVISION			
REV.	DESCRIPTION	DATE	APPROVED
B	RoHS Compliancy	06-01-06	DP
C	Updated Specifications	10-19-07	DP

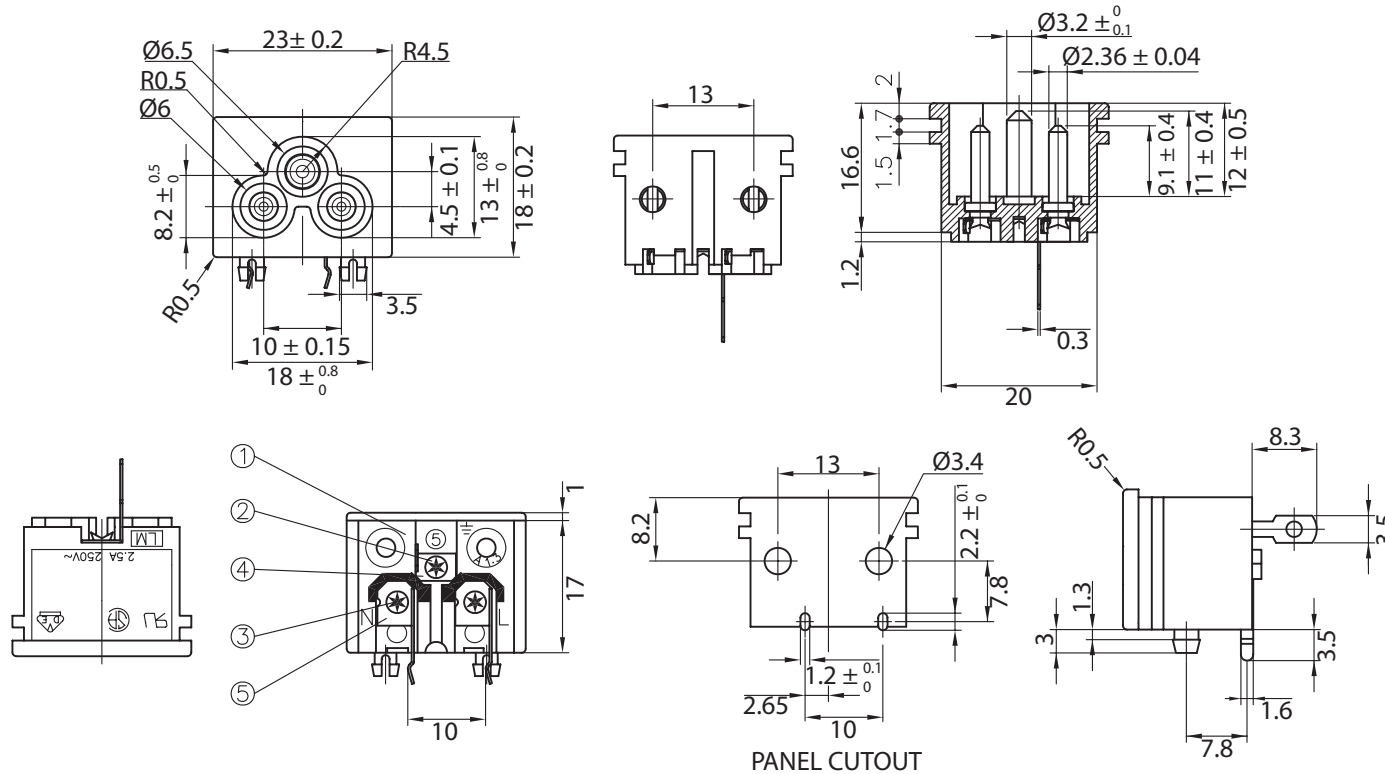

**CONTROLLED**

NOTES:

RATING: 2.5A 250V AC  
 APPROVALS: UL, CSA, VDE  
 RoHS COMPLIANT

5	Soldering PIN Brass Strip t=0.4mm Tin-Plated	2
4	Soldering PIN-TOP Brass Strip t=0.3mm Tin-Plated	1
3	Solid Contact PIN Brass Strip d=Ø2.36mm Ni-Plated	2
2	Solid Contact PIN Brass Strip d=Ø3.2mm Ni-Plated	1
1	Body Insulator PC Black Color	1

Dim range (mm)	Tolerance +/- (mm)	Qualtek Electronics Corp. PPC DIVISION		
		Part Number: 771W-BX2/01		RoHS Compliant
0-1	0.15	Description: AC RECEPTACLE		
1-6	0.20			
6-18	0.30			
18-50	0.50			
50-120	0.70	Drawn / Date	UNIT: mm	REV. C
120-250	0.90	Checked / Date		Approved / Date
250-500	1.20	B.ZHANG 04-17-02	04-17-02	JJH / 04-17-02