

DATA SHEET

Xilinx has acquired the entire Philips CoolRunner Low Power CPLD Product Family. For more technical or sales information, please see:
www.xilinx.com

XCR3032
32 macrocell CPLD

Product specification
Supersedes data of 1997 Feb 20
IC27 Data Handbook

1998 Jul 23

Philips
Semiconductors



PHILIPS

32 macrocell CPLD

XCR3032

Xilinx has acquired the entire Philips CoolRunner Low Power CPLD Product Family.
 For more technical or sales information, please see: www.xilinx.com

FEATURES

- Industry's first TotalCMOS™ PLD – both CMOS design and process technologies
- Fast Zero Power (FZP™) design technique provides ultra-low power and very high speed
- High speed pin-to-pin delays of 8ns
- Ultra-low static power of less than 35µA
- Dynamic power that is 70% lower at 50MHz than competing devices
- 100% routable with 100% utilization while all pins and all macrocells are fixed
- Deterministic timing model that is extremely simple to use
- 2 clocks with programmable polarity at every macrocell
- Support for asynchronous clocking
- Innovative XPLA™ architecture combines high speed with extreme flexibility
- 1000 erase/program cycles guaranteed
- 20 years data retention guaranteed
- Logic expandable to 37 product terms
- PCI compliant
- Advanced 0.5µ E²CMOS process
- Security bit prevents unauthorized access
- Design entry and verification using industry standard and Philips CAE tools
- Reprogrammable using industry standard device programmers
- Innovative Control Term structure provides either sum terms or product terms in each logic block for:
 - Programmable 3-State buffer
 - Asynchronous macrocell register preset/reset
- Programmable global 3-State pin facilitates 'bed of nails' testing without using logic resources
- Available in both PLCC and TQFP packages

DESCRIPTION

The PZ3032 CPLD (Complex Programmable Logic Device) is the first in a family of Fast Zero Power (FZP™) CPLDs from Philips Semiconductors. These devices combine high speed and zero power in a 32 macrocell CPLD. With the FZP™ design technique, the PZ3032 offers true pin-to-pin speeds of 8ns, while simultaneously delivering power that is less than 35µA at standby without the need for 'turbo bits' or other power down schemes. By replacing conventional sense amplifier methods for implementing product terms (a technique that has been used in PLDs since the bipolar era) with a cascaded chain of pure CMOS gates, the dynamic power is also substantially lower than any competing CPLD – 70% lower at 50MHz. These devices are the first TotalCMOS™ PLDs, as they use both a CMOS process technology **and** the patented full CMOS FZP™ design technique. For 5V applications, Philips also offers the high speed PZ5032 CPLD that offers pin-to-pin speeds of 6ns.

The Philips FZP™ CPLDs introduce the new patent-pending XPLA™ (eXtended Programmable Logic Array) architecture. The XPLA™ architecture combines the best features of both PLA and PAL™ type structures to deliver high speed and flexible logic allocation that results in superior ability to make design changes with fixed pinouts. The XPLA™ structure in each logic block provides a fast 8ns PAL™ path with 5 dedicated product terms per output. This PAL™ path is joined by an additional PLA structure that deploys a pool of 32 product terms to a fully programmable OR array that can allocate the PLA product terms to any output in the logic block. This combination allows logic to be allocated efficiently throughout the logic block and supports as many as 37 product terms on an output. The speed with which logic is allocated from the PLA array to an output is only 2.5ns, regardless of the number of PLA product terms used, which results in worst case t_{PD}'s of only 10.5ns from any pin to any other pin. In addition, logic that is common to multiple outputs can be placed on a single PLA product term and shared across multiple outputs via the OR array, effectively increasing design density.

The PZ3032 CPLDs are supported by industry standard CAE tools (Cadence, Mentor, Minc, Exemplar Logic, Synplicity, Synopsys, Synario, Viewlogic, OrCAD), using text (Abel, VHDL, Verilog) and/or schematic entry. Design verification uses industry standard simulators for functional and timing simulation. Development is supported on personal computer, Sparc, and HP platforms. Device fitting uses either Minc or Philips Semiconductors-developed tools.

The PZ3032 CPLD is reprogrammable using industry standard device programmers from vendors such as Data I/O, BP Microsystems, SMS, and others.

Table 1. PZ3032 Features

	PZ3032
Usable gates	1000
Maximum inputs	36
Maximum I/Os	32
Number of macrocells	32
I/O macrocells	32
Buried macrocells	0
Propagation delay (ns)	8.0
Packages	44-pin PLCC, 44-pin TQFP

PAL is a registered trademark of Advanced Micro Devices, Inc.

32 macrocell CPLD

PZ3032

ORDERING INFORMATION

ORDER CODE	DESCRIPTION	DESCRIPTION	DRAWING NUMBER
PZ3032-8A44	44-pin PLCC, 8ns t _{PD}	Commercial temp range, 3.3 volt power supply, ± 10%	SOT187-2
PZ3032-10A44	44-pin PLCC, 10ns t _{PD}	Commercial temp range, 3.3 volt power supply, ± 10%	SOT187-2
PZ3032-12A44	44-pin PLCC, 12ns t _{PD}	Commercial temp range, 3.3 volt power supply, ± 10%	SOT187-2
PZ3032I10A44	44-pin PLCC, 10ns t _{PD}	Industrial temp range, 3.3 volt power supply, ± 10%	SOT187-2
PZ3032I12A44	44-pin PLCC, 12ns t _{PD}	Industrial temp range, 3.3 volt power supply, ± 10%	SOT187-2
PZ3032-8BC	44-pin TQFP, 8ns t _{PD}	Commercial temp range, 3.3 volt power supply, ± 10%	SOT376-1
PZ3032-10BC	44-pin TQFP, 10ns t _{PD}	Commercial temp range, 3.3 volt power supply, ± 10%	SOT376-1
PZ3032-12BC	44-pin TQFP, 12ns t _{PD}	Commercial temp range, 3.3 volt power supply, ± 10%	SOT376-1
PZ3032I10BC	44-pin TQFP, 10ns t _{PD}	Industrial temp range, 3.3 volt power supply, ± 10%	SOT376-1
PZ3032I12BC	44-pin TQFP, 12ns t _{PD}	Industrial temp range, 3.3 volt power supply, ± 10%	SOT376-1

XPLA™ ARCHITECTURE

Figure 1 shows a high level block diagram of a 64 macrocell device implementing the XPLA™ architecture. The XPLA™ architecture consists of logic blocks that are interconnected by a Zero-power Interconnect Array (ZIA). The ZIA is a virtual crosspoint switch. Each logic block is essentially a 36V16 device with 36 inputs from the ZIA and 16 macrocells. Each logic block also provides 32 ZIA feedback paths from the macrocells and I/O pins.

From this point of view, this architecture looks like many other CPLD architectures. What makes the CoolRunner™ family unique is what is inside each logic block and the design technique used to implement these logic blocks. The contents of the logic block will be described next.

Logic Block Architecture

Figure 2 illustrates the logic block architecture. Each logic block contains control terms, a PAL array, a PLA array, and 16 macrocells. The 6 control terms can individually be configured as either SUM or

PRODUCT terms, and are used to control the preset/reset and output enables of the 16 macrocells' flip-flops. The PAL array consists of a programmable AND array with a fixed OR array, while the PLA array consists of a programmable AND array with a programmable OR array. The PAL array provides a high speed path through the array, while the PLA array provides increased product term density.

Each macrocell has 5 dedicated product terms from the PAL array. The pin-to-pin t_{PD} of the PZ3032 device through the PAL array is 8ns. This performance is the fastest 3 volt CPLD available today. If a macrocell needs more than 5 product terms, it simply gets the additional product terms from the PLA array. The PLA array consists of 32 product terms, which are available for use by all 16 macrocells. The additional propagation delay incurred by a macrocell using 1 or all 32 PLA product terms is just 2.5ns. So the total pin-to-pin t_{PD} for the PZ3032 using 6 to 37 product terms is 10.5ns (8ns for the PAL + 2.5ns for the PLA).

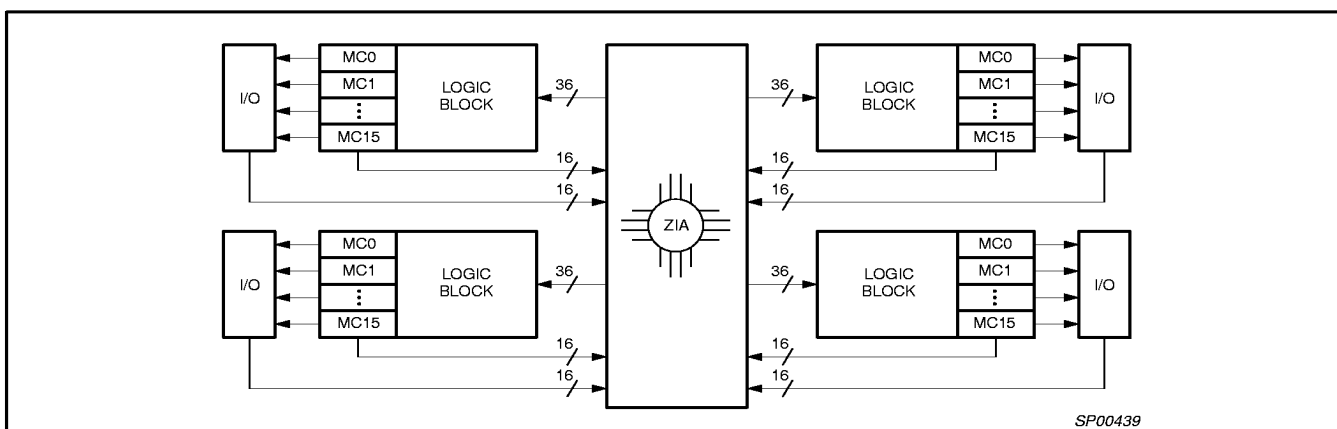

Figure 1. Philips XPLA CPLD Architecture

32 macrocell CPLD

PZ3032

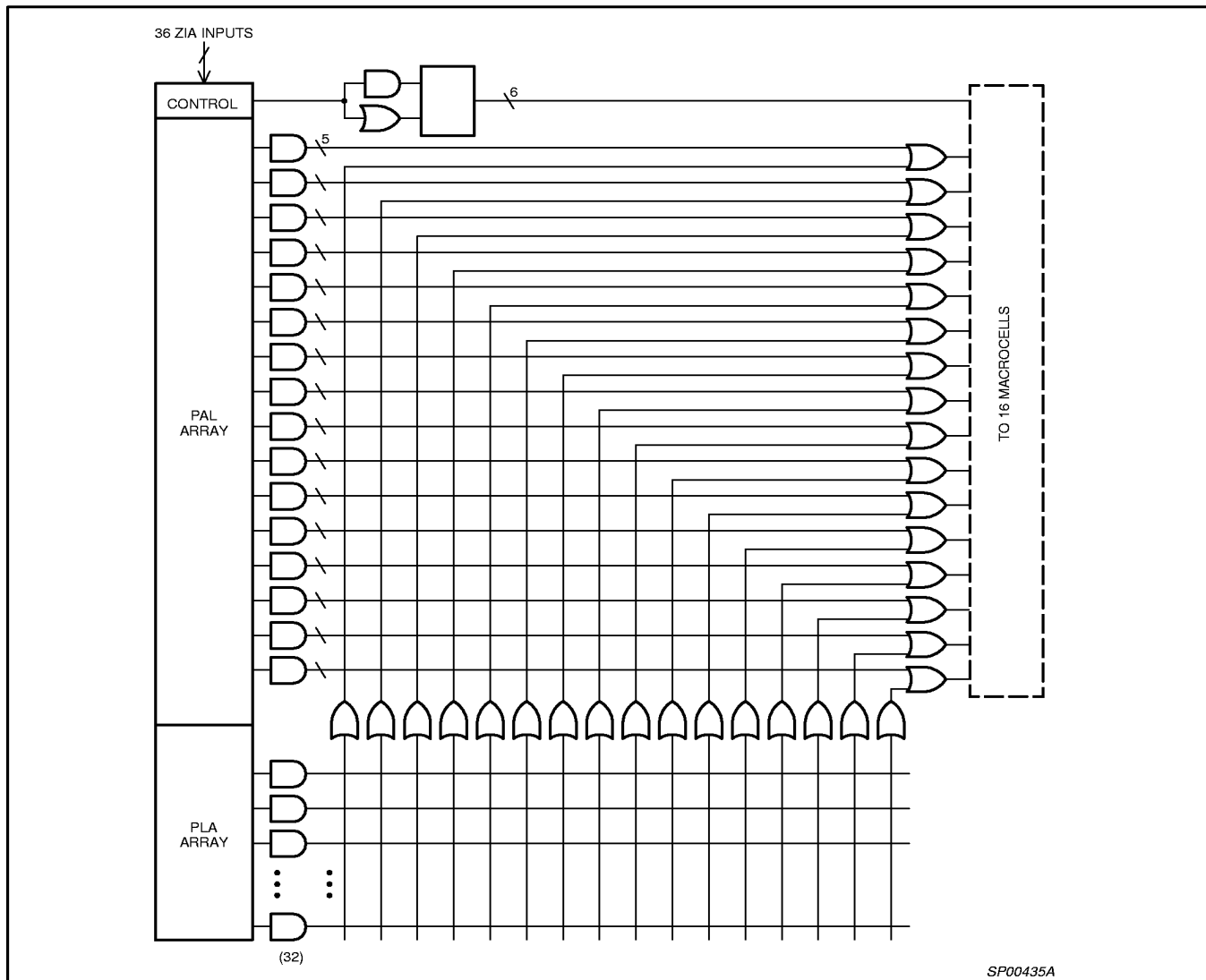

Figure 2. Philips XPLA Logic Block Architecture

32 macrocell CPLD

PZ3032

Macrocell Architecture

Figure 3 shows the architecture of the macrocell used in the CoolRunner™ family. The macrocell consists of a flip-flop that can be configured as either a D or T type. A D-type flip-flop is generally more useful for implementing state machines and data buffering. A T-type flip-flop is generally more useful in implementing counters. All CoolRunner™ family members provide both synchronous and asynchronous clocking and provide the ability to clock off either the falling or rising edges of these clocks. These devices are designed such that the skew between the rising and falling edges of a clock are minimized for clocking integrity. There are 2 clocks (CLK0 and CLK1) available on the PZ3032 device. Clock 0 (CLK0) is designated as the “synchronous” clock and must be driven by an external source. Clock 1 (CLK1) can either be used as a synchronous clock (driven by an external source) or as an asynchronous clock (driven by a macrocell equation). The timing for asynchronous clocks is different in that the t_{CO} time is extended by the amount of time that it takes for the signal to propagate through the array and reach the clock network, and the t_{SU} time is reduced. Please see the application note titled “Understanding CoolRunner Clocking Options” for more detail.

Two of the control terms (CT0 and CT1) are used to control the Preset/Reset of the macrocell’s flip-flop. The Preset/Reset feature

for each macrocell can also be disabled. Note that the Power-on Reset leaves all macrocells in the “zero” state when power is properly applied. The other 4 control terms (CT2–CT5) can be used to control the Output Enable of the macrocell’s output buffers. The reason there are as many control terms dedicated for the Output Enable of the macrocell is to insure that all CoolRunner™ devices are PCI compliant. The macrocell’s output buffers can also be always enabled or disabled. All CoolRunner™ devices also provide a Global Tri-State (GTS) pin, which, when enabled and pulled Low, will 3-State all the outputs of the device. This pin is provided to support “In-Circuit Testing” or “Bed-of-Nails Testing”.

There are two feedback paths to the ZIA: one from the macrocell, and one from the I/O pin. The ZIA feedback path before the output buffer is the macrocell feedback path, while the ZIA feedback path after the output buffer is the I/O pin ZIA path. When the macrocell is used as an output, the output buffer is enabled, and the macrocell feedback path can be used to feedback the logic implemented in the macrocell. When the I/O pin is used as an input, the output buffer will be 3-States and the input signal will be fed into the ZIA via the I/O feedback path, and the logic implemented in the buried macrocell can be fed back to the ZIA via the macrocell feedback path. It should be noted that unused inputs or I/Os should be properly terminated.

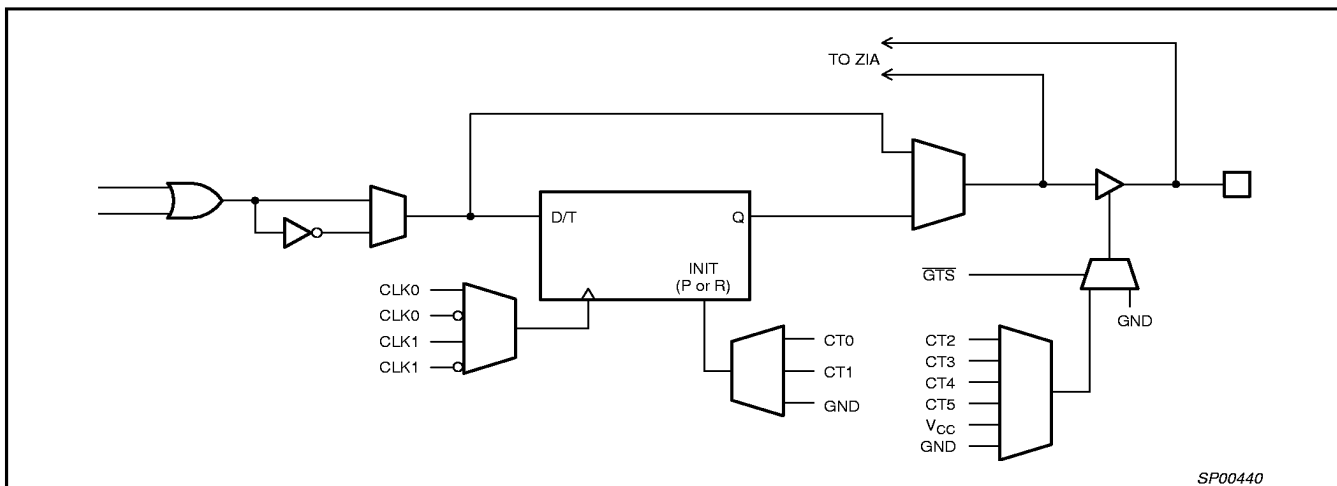

Figure 3. PZ3032 Macrocell Architecture

32 macrocell CPLD

PZ3032

Simple Timing Model

Figure 4 shows the CoolRunner™ Timing Model. The CoolRunner™ timing model looks very much like a 22V10 timing model in that there are three main timing parameters, including t_{PD} , t_{SU} , and t_{CO} . In other competing architectures, the user may be able to fit the design into the CPLD, but is not sure whether system timing requirements can be met until after the design has been fit into the device. This is because the timing models of competing architectures are very complex and include such things as timing dependencies on the number of parallel expanders borrowed, sharable expanders, varying number of X and Y routing channels used, etc. In the XPLA™ architecture, the user knows up front whether the design will meet system timing requirements. This is due to the simplicity of the timing model. For example, in the PZ3032 device, the user knows up front that if a given output uses 5

product terms or less, the $t_{PD} = 8ns$, the $t_{SU} = 6.5ns$, and the $t_{CO} = 7.5ns$. If an output is using 6 to 37 product terms, an additional 2.5ns must be added to the t_{PD} and t_{SU} timing parameters to account for the time to propagate through the PLA array.

TotalCMOS™ Design Technique for Fast Zero Power

Philips is the first to offer a TotalCMOS™ CPLD, both in process technology and design technique. Philips employs a cascade of CMOS gates to implement its Sum of Products instead of the traditional sense amp approach. This CMOS gate implementation allows Philips to offer CPLDs which are both high performance and low power, breaking the paradigm that to have low power, you must have low performance. Refer to Figure 5 and Table 2 showing the I_{DD} vs. Frequency of our PZ3032 TotalCMOS™ CPLD.

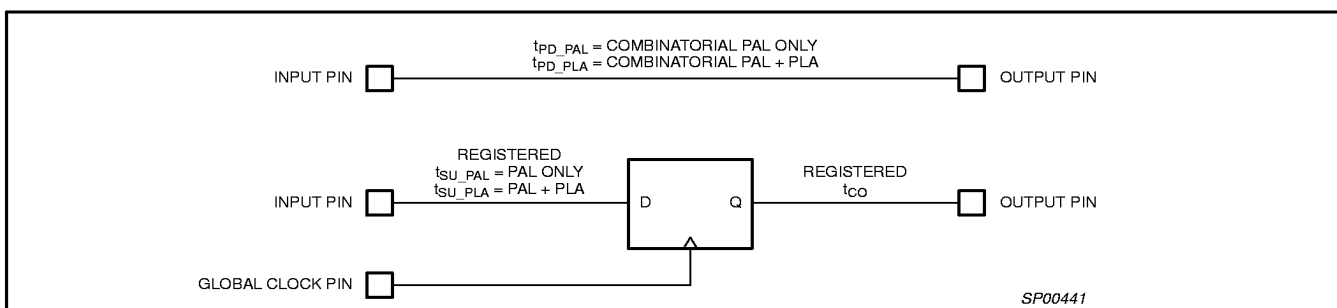

Figure 4. CoolRunner™ Timing Model

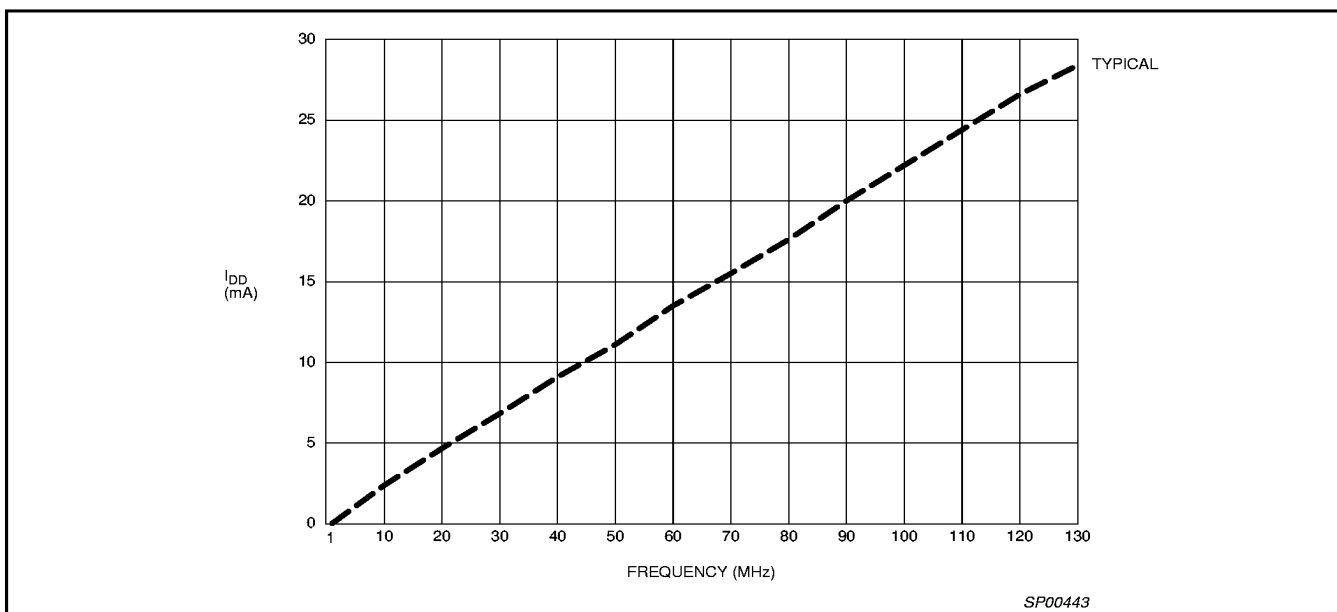

Figure 5. I_{DD} vs. Frequency @ V_{DD} = 3.3V

Table 2. I_{DD} vs Frequency

V_{DD} = 3.3V

FREQ (MHz)	0	10	20	30	40	50	60	70	80	90	100	110	120	130
Typical I _{DD} (mA)	0.01	2.37	4.65	6.80	9.06	11.1	13.5	15.5	17.4	20.0	22.1	24.4	26.6	28.5

32 macrocell CPLD

PZ3032

ABSOLUTE MAXIMUM RATINGS¹

SYMBOL	PARAMETER	MIN.	MAX.	UNIT
V _{DD}	Supply voltage ²	-0.5	7.0	V
V _I	Input voltage	-1.2	V _{DD} +0.5	V
V _{OUT}	Output voltage	-0.5	V _{DD} +0.5	V
I _{IN}	Input current	-30	30	mA
I _{OUT}	Output current	-100	100	mA
T _J	Maximum junction temperature	-40	150	°C
T _{str}	Storage temperature	-65	150	°C

NOTES:

1. Stresses above those listed may cause malfunction or permanent damage to the device. This is a stress rating only. Functional operation at these or any other condition above those indicated in the operational and programming specification is not implied.
2. The chip supply voltage must be monotonic.

OPERATING RANGE

PRODUCT GRADE	TEMPERATURE	VOLTAGE
Commercial	0 to +70°C	3.3 ±10% V
Industrial	-40 to +85°C	3.3 ±10% V

32 macrocell CPLD

PZ3032

DC ELECTRICAL CHARACTERISTICS FOR COMMERCIAL GRADE DEVICESCommercial: $0^{\circ}\text{C} \leq T_{\text{amb}} \leq +70^{\circ}\text{C}$; $3.0\text{V} \leq V_{\text{DD}} \leq 3.6\text{V}$

SYMBOL	PARAMETER	TEST CONDITIONS	MIN.	MAX.	UNIT
V_{IL}	Input voltage low	$V_{\text{DD}} = 3.0\text{V}$		0.8	V
V_{IH}	Input voltage high	$V_{\text{DD}} = 3.6\text{V}$	2.0		V
V_{I}	Input clamp voltage	$V_{\text{DD}} = 3.0\text{V}$, $I_{\text{IN}} = -18\text{mA}$		-1.2	V
V_{OL}	Output voltage low	$V_{\text{DD}} = 3.0\text{V}$, $I_{\text{OL}} = 8\text{mA}$		0.5	V
V_{OH}	Output voltage high	$V_{\text{DD}} = 3.0\text{V}$, $I_{\text{OH}} = -8\text{mA}$	2.4		V
I_{IL}	Input leakage current low	$V_{\text{DD}} = 3.6\text{V}$ (except CKO), $V_{\text{IN}} = 0\text{V}$	-10	10	μA
I_{IH}	Input leakage current high	$V_{\text{DD}} = 3.6\text{V}$, $V_{\text{IN}} = 3.0\text{V}$	-10	10	μA
I_{IL}	Clock input leakage current	$V_{\text{DD}} = 3.6\text{V}$, $V_{\text{IN}} = 0.4\text{V}$	-10	10	μA
I_{OZL}	3-States output leakage current low	$V_{\text{DD}} = 3.6\text{V}$, $V_{\text{IN}} = 0.4\text{V}$	-10	10	μA
I_{OZH}	3-States output leakage current high	$V_{\text{DD}} = 3.6\text{V}$, $V_{\text{IN}} = 3.0\text{V}$	-10	10	μA
I_{DDQ}^1	Standby current	$V_{\text{DD}} = 3.6\text{V}$, $T_{\text{amb}} = 0^{\circ}\text{C}$		35	μA
$I_{\text{DDD}}^{1,2}$	Dynamic current	$V_{\text{DD}} = 3.6\text{V}$, $T_{\text{amb}} = 0^{\circ}\text{C}$ @ 1MHz		0.5	mA
		$V_{\text{DD}} = 3.6\text{V}$, $T_{\text{amb}} = 0^{\circ}\text{C}$ @ 50MHz		18	mA
I_{OS}	Short circuit output current ³	1 pin at a time for no longer than 1 second	-5	-100	mA
C_{IN}	Input pin capacitance ³	$T_{\text{amb}} = 25^{\circ}\text{C}$, $f = 1\text{MHz}$		8	pF
C_{CLK}	Clock input capacitance ³	$T_{\text{amb}} = 25^{\circ}\text{C}$, $f = 1\text{MHz}$	5	12	pF
$C_{\text{I/O}}$	I/O pin capacitance ³	$T_{\text{amb}} = 25^{\circ}\text{C}$, $f = 1\text{MHz}$		10	pF

NOTES:

- See Table 2 on page 6 for typical values.
- This parameter measured with a 16-bit, loadable up/down counter loaded into every logic block, with all outputs enabled and unloaded. Inputs are tied to V_{DD} or ground. This parameter guaranteed by design and characterization, not testing.
- Typical values, not tested.

AC ELECTRICAL CHARACTERISTICS¹ FOR COMMERCIAL GRADE DEVICESCommercial: $0^{\circ}\text{C} \leq T_{\text{amb}} \leq +70^{\circ}\text{C}$; $3.0\text{V} \leq V_{\text{DD}} \leq 3.6\text{V}$

SYMBOL	PARAMETER	8		10		12		UNIT
		MIN.	MAX.	MIN.	MAX.	MIN.	MAX.	
$t_{\text{PD_PAL}}$	Propagation delay time, input (or feedback node) to output through PAL	2	8	2	10	2	12	ns
$t_{\text{PD_PLA}}$	Propagation delay time, input (or feedback node) to output through PAL & PLA	3	10.5	3	13	3	15	ns
t_{CO}	Clock to out (global synchronous clock from pin)	2	7	2	9	2	11	ns
$t_{\text{SU_PAL}}$	Setup time (from input or feedback node) through PAL	6.5		8.5		10.5		ns
$t_{\text{SU_PLA}}$	Setup time (from input or feedback node) through PAL + PLA	9		11.5		13.5		ns
t_{H}	Hold time		0		0		0	ns
t_{CH}	Clock High time	3		4		5		ns
t_{CL}	Clock Low time	3		4		5		ns
t_{R}	Input rise time		20		20		20	ns
t_{F}	Input fall time		20		20		20	ns
f_{MAX1}	Maximum FF toggle rate ² ($1/t_{\text{CH}} + t_{\text{CL}}$)	167		125		100		MHz
f_{MAX2}	Maximum internal frequency ² ($1/t_{\text{SUPAL}} + t_{\text{CF}}$)	83		63		50		MHz
f_{MAX3}	Maximum external frequency ² ($1/t_{\text{SUPAL}} + t_{\text{CO}}$)	74		57		47		MHz
t_{BUF}	Output buffer delay time		1.5		1.5		1.5	ns
$t_{\text{PDF_PAL}}$	Input (or feedback node) to internal feedback node delay time through PAL		6.5		8.5		10.5	ns
$t_{\text{PDF_PLA}}$	Input (or feedback node) to internal feedback node delay time through PAL + PLA		9		11.5		13.5	ns
t_{CF}	Clock to internal feedback node delay time		5.5		7.5		9.5	ns
t_{INIT}	Delay from valid V_{DD} to valid reset		50		50		50	μs
t_{ER}	Input to output disable ³		15		17		19	ns
t_{EA}	Input to output valid		15		17		19	ns
t_{RP}	Input to register preset		16		18		20	ns
t_{RR}	Input to register reset		19		21		23	ns

NOTES:

- Specifications measured with one output switching. See Figure 6 and Table 3 for derating.
- This parameter guaranteed by design and characterization, not by test.
- Output $C_{\text{L}} = 5\text{pF}$.

32 macrocell CPLD

PZ3032

DC ELECTRICAL CHARACTERISTICS FOR INDUSTRIAL GRADE DEVICESIndustrial: $-40^{\circ}\text{C} \leq T_{\text{amb}} \leq +85^{\circ}\text{C}$; $3.0\text{V} \leq V_{\text{DD}} \leq 3.6\text{V}$

SYMBOL	PARAMETER	TEST CONDITIONS	MIN.	MAX.	UNIT
V_{IL}	Input voltage low	$V_{\text{DD}} = 3.0\text{V}$		0.8	V
V_{IH}	Input voltage high	$V_{\text{DD}} = 3.6\text{V}$	2.0		V
V_{I}	Input clamp voltage	$V_{\text{DD}} = 3.0\text{V}$, $I_{\text{IN}} = -18\text{mA}$		-1.2	V
V_{OL}	Output voltage low	$V_{\text{DD}} = 3.0\text{V}$, $I_{\text{OL}} = 8\text{mA}$		0.5	V
V_{OH}	Output voltage high	$V_{\text{DD}} = 3.0\text{V}$, $I_{\text{OH}} = -8\text{mA}$	2.4		V
I_{IL}	Input leakage current low	$V_{\text{DD}} = 3.6\text{V}$ (except CKO), $V_{\text{IN}} = 0.4\text{V}$	-10	10	μA
I_{IH}	Input leakage current high	$V_{\text{DD}} = 3.6\text{V}$, $V_{\text{IN}} = 3.0\text{V}$	-10	10	μA
I_{IL}	Clock input leakage current	$V_{\text{DD}} = 3.6\text{V}$, $V_{\text{IN}} = 0.4\text{V}$	-10	10	μA
I_{OZL}	3-States output leakage current low	$V_{\text{DD}} = 3.6\text{V}$, $V_{\text{IN}} = 0.4\text{V}$	-10	10	μA
I_{OZH}	3-States output leakage current high	$V_{\text{DD}} = 3.6\text{V}$, $V_{\text{IN}} = 3.0\text{V}$	-10	10	μA
I_{DDQ}^1	Standby current	$V_{\text{DD}} = 3.6\text{V}$, $T_{\text{amb}} = -40^{\circ}\text{C}$		45	μA
$I_{\text{DDD}}^{1,2}$	Dynamic current	$V_{\text{DD}} = 3.6\text{V}$, $T_{\text{amb}} = -40^{\circ}\text{C}$ @ 1MHz		0.5	mA
		$V_{\text{DD}} = 3.6\text{V}$, $T_{\text{amb}} = -40^{\circ}\text{C}$ @ 50MHz		18	mA
I_{OS}	Short circuit output current ³	1 pin at a time for no longer than 1 second	-5	-120	mA
C_{IN}	Input pin capacitance ³	$T_{\text{amb}} = 25^{\circ}\text{C}$, $f = 1\text{MHz}$		8	pF
C_{CLK}	Clock input capacitance ³	$T_{\text{amb}} = 25^{\circ}\text{C}$, $f = 1\text{MHz}$	5	12	pF
$C_{\text{I/O}}$	I/O pin capacitance ³	$T_{\text{amb}} = 25^{\circ}\text{C}$, $f = 1\text{MHz}$		10	pF

NOTES:

- See Table 2 on page 6 for typical values.
- This parameter measured with a 16-bit, loadable up/down counter loaded into every logic block, with all outputs enabled and unloaded. Inputs are tied to V_{DD} or ground. This parameter guaranteed by design and characterization, not testing.
- Typical values, not tested.

AC ELECTRICAL CHARACTERISTICS¹ FOR INDUSTRIAL GRADE DEVICESIndustrial: $-40^{\circ}\text{C} \leq T_{\text{amb}} \leq +85^{\circ}\text{C}$; $3.0\text{V} \leq V_{\text{DD}} \leq 3.6\text{V}$

SYMBOL	PARAMETER	10		12		UNIT
		MIN.	MAX.	MIN.	MAX.	
$t_{\text{PD_PAL}}$	Propagation delay time, input (or feedback node) to output through PAL	2	10	2	12	ns
$t_{\text{PD_PLA}}$	Propagation delay time, input (or feedback node) to output through PAL & PLA	3	12.5	3	15	ns
t_{CO}	Clock to out (global synchronous clock from pin)	2	9	2	11	ns
$t_{\text{SU_PAL}}$	Setup time (from input or feedback node) through PAL	8		10.5		ns
$t_{\text{SU_PLA}}$	Setup time (from input or feedback node) through PAL + PLA	10.5		13.5		ns
t_{H}	Hold time		0		0	ns
t_{CH}	Clock High time	4		5		ns
t_{CL}	Clock Low time	4		5		ns
t_{R}	Input rise time		20		20	ns
t_{F}	Input fall time		20		20	ns
f_{MAX1}	Maximum FF toggle rate ² ($1/t_{\text{CH}} + t_{\text{CL}}$)	125		100		MHz
f_{MAX2}	Maximum internal frequency ² ($1/t_{\text{SUPAL}} + t_{\text{CF}}$)	64.5		50		MHz
f_{MAX3}	Maximum external frequency ² ($1/t_{\text{SUPAL}} + t_{\text{CO}}$)	58.8		47		MHz
t_{BUF}	Output buffer delay time		1.5		1.5	ns
$t_{\text{PDF_PAL}}$	Input (or feedback node) to internal feedback node delay time through PAL		8		10.5	ns
$t_{\text{PDF_PLA}}$	Input (or feedback node) to internal feedback node delay time through PAL + PLA		10.5		13.5	ns
t_{CF}	Clock to internal feedback delay time		7.5		9.5	ns
t_{INIT}	Delay from valid V_{DD} to valid reset		50		50	μs
t_{ER}	Input to output disable ³		16		19	ns
t_{EA}	Input to output valid		16		19	ns
t_{RP}	Input to register preset		17		20	ns
t_{RR}	Input to register reset		20		23	ns

NOTES:

- Specifications measured with one output switching. See Figure 6 and Table 3 for derating.
- This parameter guaranteed by design and characterization, not by test.
- Output $C_{\text{L}} = 5\text{pF}$.

32 macrocell CPLD

PZ3032

SWITCHING CHARACTERISTICS

The test load circuit and load values for the AC Electrical Characteristics are illustrated below.

COMPONENT	VALUES
R1	390Ω
R2	390Ω
C1	35pF

MEASUREMENT	S1	S2
t _{PZH}	Open	Closed
t _{PZL}	Closed	Closed
t _p	Closed	Closed

NOTE: For t_{PHZ} and t_{PLZ} C = 5pF, and 3-State levels are measured 0.5V from steady-state active level.

SP00477

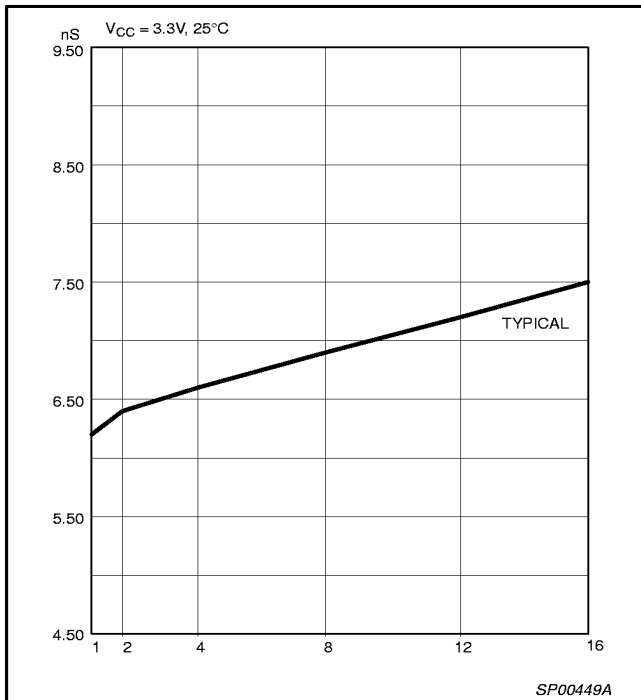

Figure 6. t_{PD_PAL} vs. Outputs switching

Table 3. t_{PD_PAL} vs. # of Outputs switching

V_{DD} = 3.30V

# of Outputs	1	2	4	8	12	16
Typical (ns)	6.2	6.4	6.6	6.9	7.2	7.5

VOLTAGE WAVEFORM

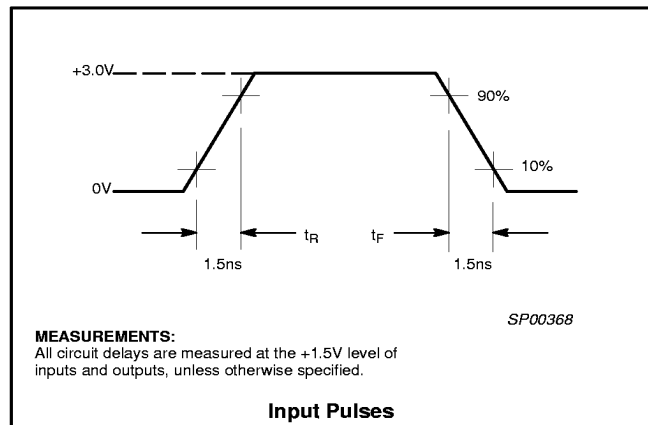

32 macrocell CPLD

PZ3032

PIN DESCRIPTIONS

PZ3032 – 44-Pin Plastic Leaded Chip Carrier

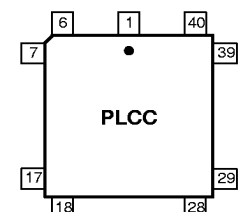

Pin	Function	Pin	Function	Pin	Function
1	IN1	16	I/O-A10	31	I/O-B9
2	IN3	17	I/O-A11	32	I/O-B8
3	V _{DD}	18	I/O-A12	33	I/O-B7
4	I/O-A0-CK1	19	I/O-A13	34	I/O-B6
5	I/O-A1	20	I/O-A14	35	V _{DD}
6	I/O-A2	21	I/O-A15	36	I/O-B5
7	I/O-A3	22	GND	37	I/O-B4
8	I/O-A4	23	V _{DD}	38	I/O-B3
9	I/O-A5	24	I/O-B15	39	I/O-B2
10	GND	25	I/O-B14	40	I/O-B1
11	I/O-A6	26	I/O-B13	41	I/O-B0
12	I/O-A7	27	I/O-B12	42	GND
13	I/O-A8	28	I/O-B11	43	IN0-CK0
14	I/O-A9	29	I/O-B10	44	IN2-gtsn
15	V _{DD}	30	GND		

SP00420

PZ3032 – 44-Pin Thin Quad Flat Package

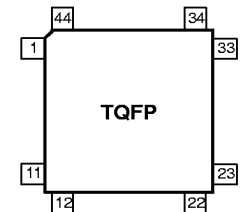

Pin	Function	Pin	Function	Pin	Function
1	I/O-A3	16	GND	31	I/O-B4
2	I/O-A4	17	V _{DD}	32	I/O-B3
3	I/O-A5	18	I/O-B15	33	I/O-B2
4	GND	19	I/O-B14	34	I/O-B1
5	I/O-A6	20	I/O-B13	35	I/O-B0
6	I/O-A7	21	I/O-B12	36	GND
7	I/O-A8	22	I/O-B11	37	IN0/CK0
8	I/O-A9	23	I/O-B10	38	IN2-gtsn
9	V _{DD}	24	GND	39	IN1
10	I/O-A10	25	I/O-B9	40	IN3
11	I/O-A11	26	I/O-B8	41	V _{DD}
12	I/O-A12	27	I/O-B7	42	I/O-A0-CK1
13	I/O-A13	28	I/O-B6	43	I/O-A1
14	I/O-A14	29	V _{DD}	44	I/O-A2
15	I/O-A15	30	I/O-B5		

SP00433

Package Thermal Characteristics

Philips Semiconductors uses the Temperature Sensitive Parameter (TSP) method to test thermal resistance. This method meets Mil-Std-883C Method 1012.1 and is described in Philips 1995 IC Package Databook. Thermal resistance varies slightly as a function of input power. As input power increases, thermal resistance changes approximately 5% for a 100% change in power.

Figure 7 is a derating curve for the change in Θ_{JA} with airflow based on wind tunnel measurements. It should be noted that the wind flow dynamics are more complex and turbulent in actual applications than in a wind tunnel. Also, the test boards used in the wind tunnel contribute significantly to forced convection heat transfer, and may not be similar to the actual circuit board, especially in size.

Package	Θ_{JA}
44-pin PLCC	49.8°C/W
44-pin TQFP	66.3°C/W

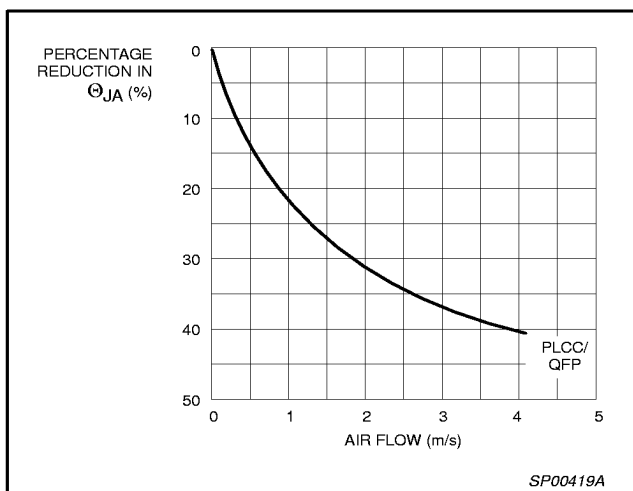

Figure 7. Average Effect of Airflow on Θ_{JA}

32 macrocell CPLD

PZ3032

PLCC44: plastic leaded chip carrier; 44 leads

SOT187-2

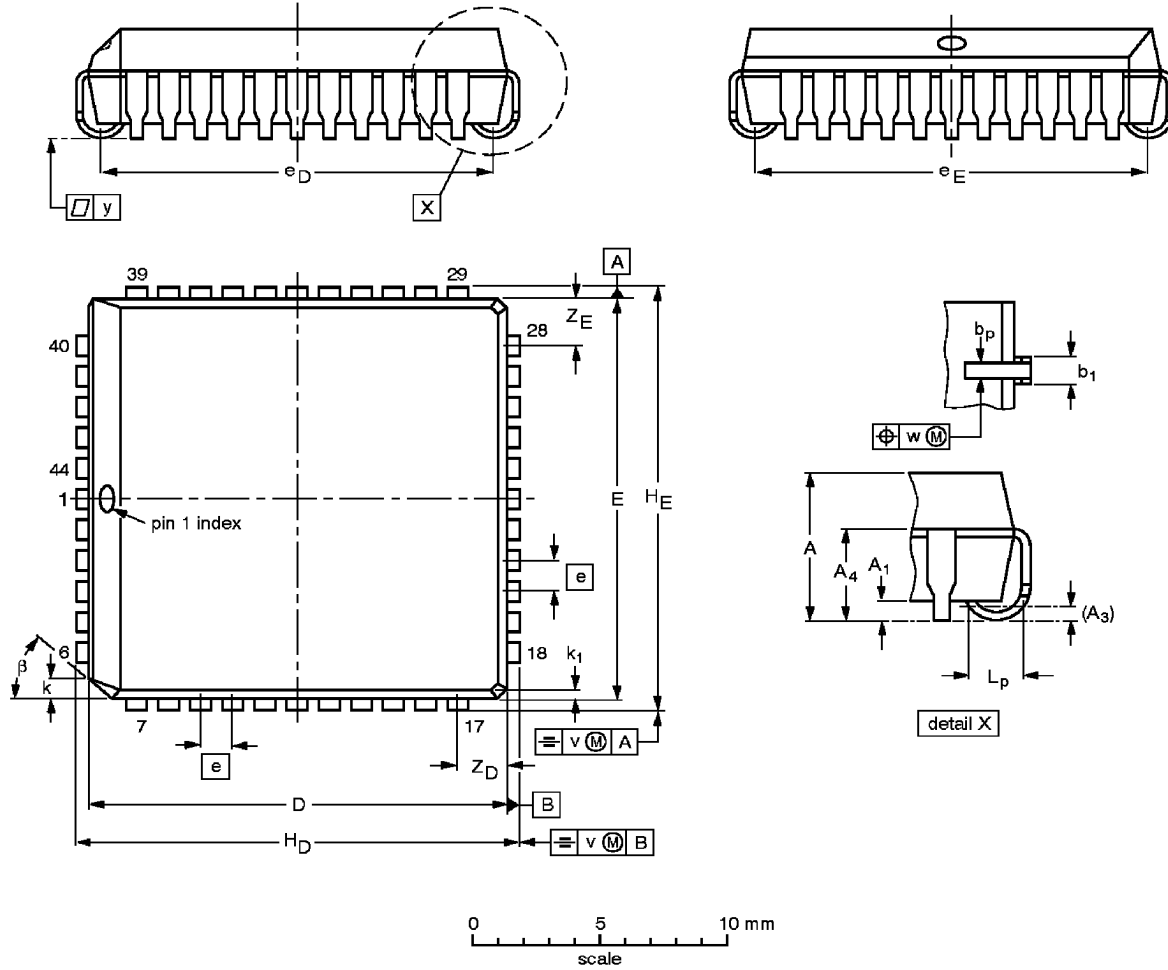

DIMENSIONS (millimetre dimensions are derived from the original inch dimensions)

UNIT	A	A ₁ min.	A ₃	A ₄ max.	b _p	b ₁	D ⁽¹⁾	E ⁽¹⁾	e	e _D	e _E	H _D	H _E	k	k ₁ max.	L _p	v	w	y	Z _D ⁽¹⁾ max.	Z _E ⁽¹⁾ max.	β
mm	4.57 4.19	0.51	0.25	3.05	0.53 0.33	0.81 0.66	16.66 16.51	16.66 16.51	1.27	16.00 14.99	16.00 14.99	17.65 17.40	17.65 17.40	1.22 1.07	0.51	1.44 1.02	0.18	0.18	0.10	2.16	2.16	45°
inches	0.180 0.165	0.020	0.01	0.12	0.021 0.013	0.032 0.026	0.656 0.650	0.656 0.650	0.05	0.630 0.590	0.630 0.590	0.695 0.685	0.695 0.685	0.048 0.042	0.020	0.057 0.040	0.007	0.007	0.004	0.085	0.085	

Note

1. Plastic or metal protrusions of 0.01 inches maximum per side are not included.

OUTLINE VERSION	REFERENCES				EUROPEAN PROJECTION	ISSUE DATE
	IEC	JEDEC	EIAJ			
SOT187-2	112E10	MO-047AC				92-11-17 95-02-25

32 macrocell CPLD

PZ3032

TQFP44: plastic thin quad flat package; 44 leads; body 10 x 10 x 1.0 mm

SOT376-1

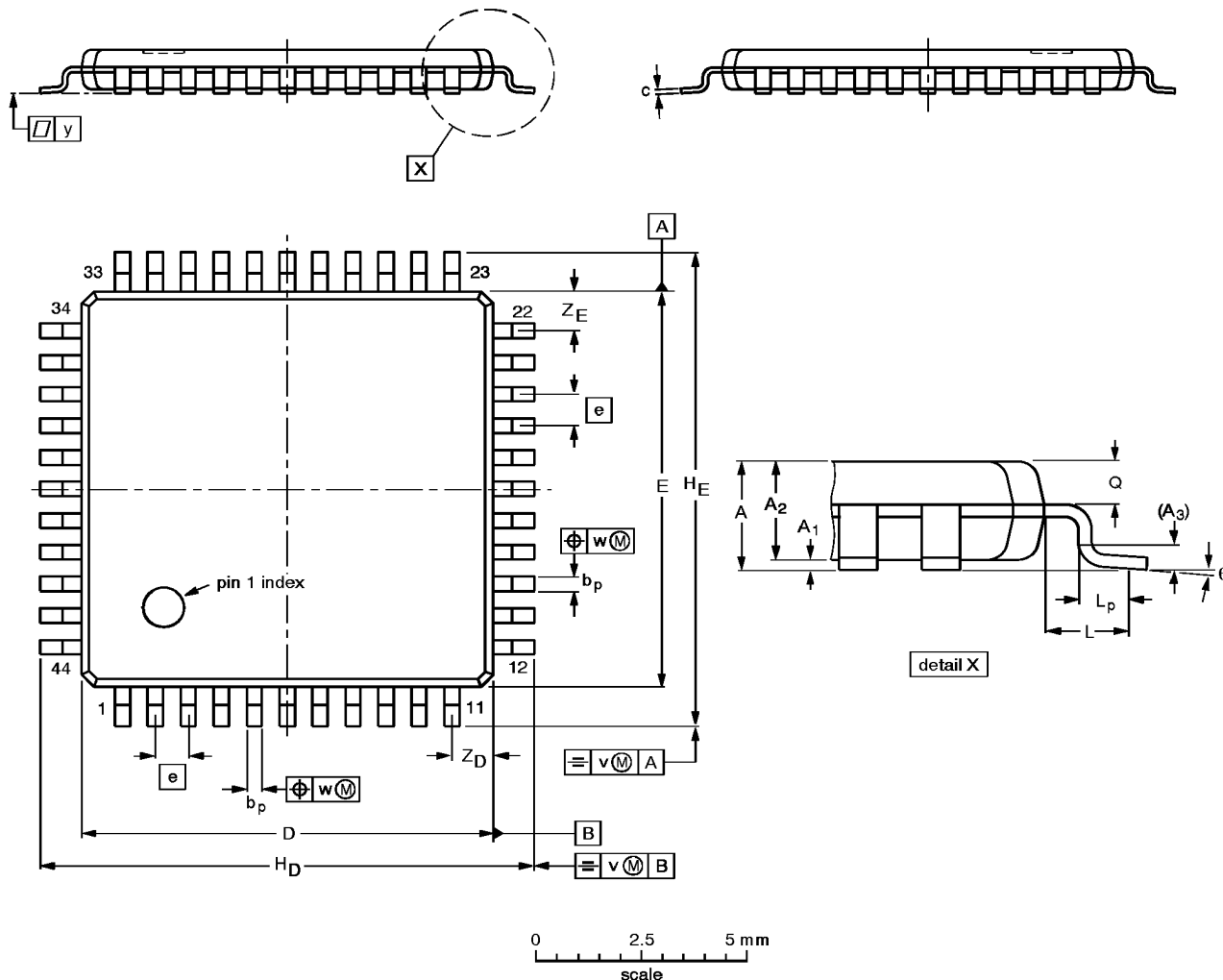

DIMENSIONS (mm are the original dimensions)

UNIT	A max.	A ₁	A ₂	A ₃	b _p	c	D ⁽¹⁾	E ⁽¹⁾	e	H _D	H _E	L	L _p	Q	v	w	y	Z _D ⁽¹⁾	Z _E ⁽¹⁾	θ
mm	1.2	0.15 0.05	1.05 0.95	0.25	0.45 0.30	0.18 0.12	10.1 9.9	10.1 9.9	0.8	12.15 11.85	12.15 11.85	1.0	0.75 0.45	0.50 0.36	0.2	0.2	0.1	1.2 0.8	1.2 0.8	7° 0°

Note

1. Plastic or metal protrusions of 0.25 mm maximum per side are not included.

OUTLINE VERSION	REFERENCES				EUROPEAN PROJECTION	ISSUE DATE
	IEC	JEDEC	EIAJ			
SOT376-1						95-05-22 96-04-02