



# CML Semiconductor Products

## CTCSS/DCS/SELCALL Processor **FX828**

D/828/4 August 2009

Provisional Issue

### 1.0 Features

- Fast CTCSS Detection
- Full 23/24 Bit DCS Codec
- Non-Predictive Tone Detection
- Low Power 3.3V/5V Operation
- Variable Gain Audio Filter
- Programmable Tone Decoder
- Programmable Comparator for RSSI
- Programmable Modulator Drivers
- Programmable Tone Encoders
- Full Duplex CTCSS and Selcall

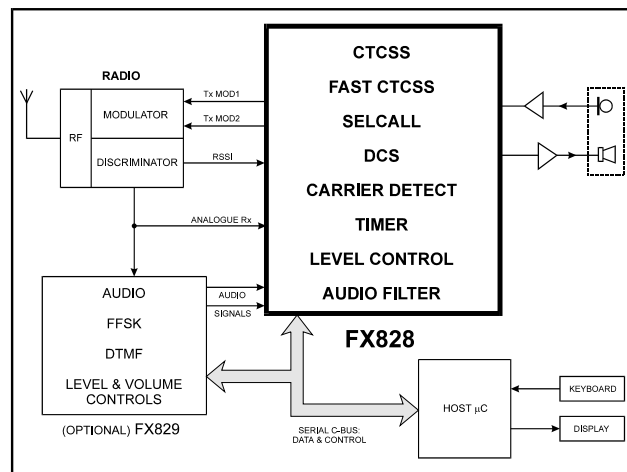

### 1.1 Brief Description

The FX828 is an innovative CTCSS, DCS and Selcall Codec, designed for the latest generation of Land Mobile Radio equipment. Designed to complement the FX829, the FX828 has many advanced features which assist the operation of modern SUBAUDIO and INBAND based signalling systems. The FX828 is electrically, physically and software compatible with the FX818 and FX829. It permits manufacturers to add new features to their equipment with minimal design changes.

The FX828 incorporates a programmable tone decoder which can be set to respond to between 1 and 15 CTCSS or Selcall tones with minimum software intervention. In addition, a 'Fast' CTCSS detector can respond to a single programmed tone in 60 ms, or can be used to provide an output if any CTCSS tone is present at the detector input. Two high resolution tone encoders perform accurate generation of any CTCSS or Selcall tone in current use. Full 23 or 24 bit DCS encoding and decoding complements the CTCSS/Selcall line-up. A timer is included which, for example, may be used for timing Selcall transmissions and a comparator is provided to assist with carrier or RSSI monitoring. The device can operate full duplex in all operating modes except for DCS.

The FX828 along with the FX818 and FX829 is offered in a choice of small SSOP, DIL and SOIC 24-pin packages. It may be used with 3.0 to 5.5 volt supply.

<u>Section</u>	<b>CONTENTS</b>	<u>Page</u>
<b>1.0</b>	<b>Features .....</b>	<b>1</b>
<b>1.2</b>	<b>Block Diagram .....</b>	<b>3</b>
<b>1.3</b>	<b>Signal List .....</b>	<b>4</b>
<b>1.3</b>	<b>Signal List .....</b>	<b>4</b>
<b>1.4</b>	<b>External Components .....</b>	<b>6</b>
<b>1.4</b>	<b>External Components .....</b>	<b>6</b>
<b>1.5</b>	<b>General Description .....</b>	<b>7</b>
<b>1.5.1</b>	<b>Software Description .....</b>	<b>7</b>
<b>1.6</b>	<b>Application Notes .....</b>	<b>20</b>
<b>1.6.1</b>	<b>General .....</b>	<b>20</b>
<b>1.6.2</b>	<b>Transmitter .....</b>	<b>20</b>
<b>1.6.3</b>	<b>Receiver (Decode) .....</b>	<b>21</b>
<b>1.6.4</b>	<b>Receiver (Fast Detect) .....</b>	<b>21</b>
<b>1.6.5</b>	<b>Receiver (DCS Decoder) .....</b>	<b>21</b>
<b>1.6.6</b>	<b>General Purpose Timer .....</b>	<b>22</b>
<b>1.6.7</b>	<b>Full Duplex Modes .....</b>	<b>22</b>
<b>1.6.8</b>	<b>Tx / Fast Rx Tone Table .....</b>	<b>23</b>
<b>1.6.9</b>	<b>Rx Program Tone Table .....</b>	<b>23</b>
<b>1.6.10</b>	<b>Tx Tone Program Table : Selcall .....</b>	<b>24</b>
<b>1.6.11</b>	<b>Rx Tone Program Table : Selcall .....</b>	<b>25</b>
<b>1.6.12</b>	<b>Tx DCS Code Table .....</b>	<b>26</b>
<b>1.7</b>	<b>Performance Specification .....</b>	<b>27</b>
<b>1.7.1</b>	<b>Electrical Performance .....</b>	<b>27</b>
<b>1.7.2</b>	<b>Packaging .....</b>	<b>33</b>

## 1.2 Block Diagram

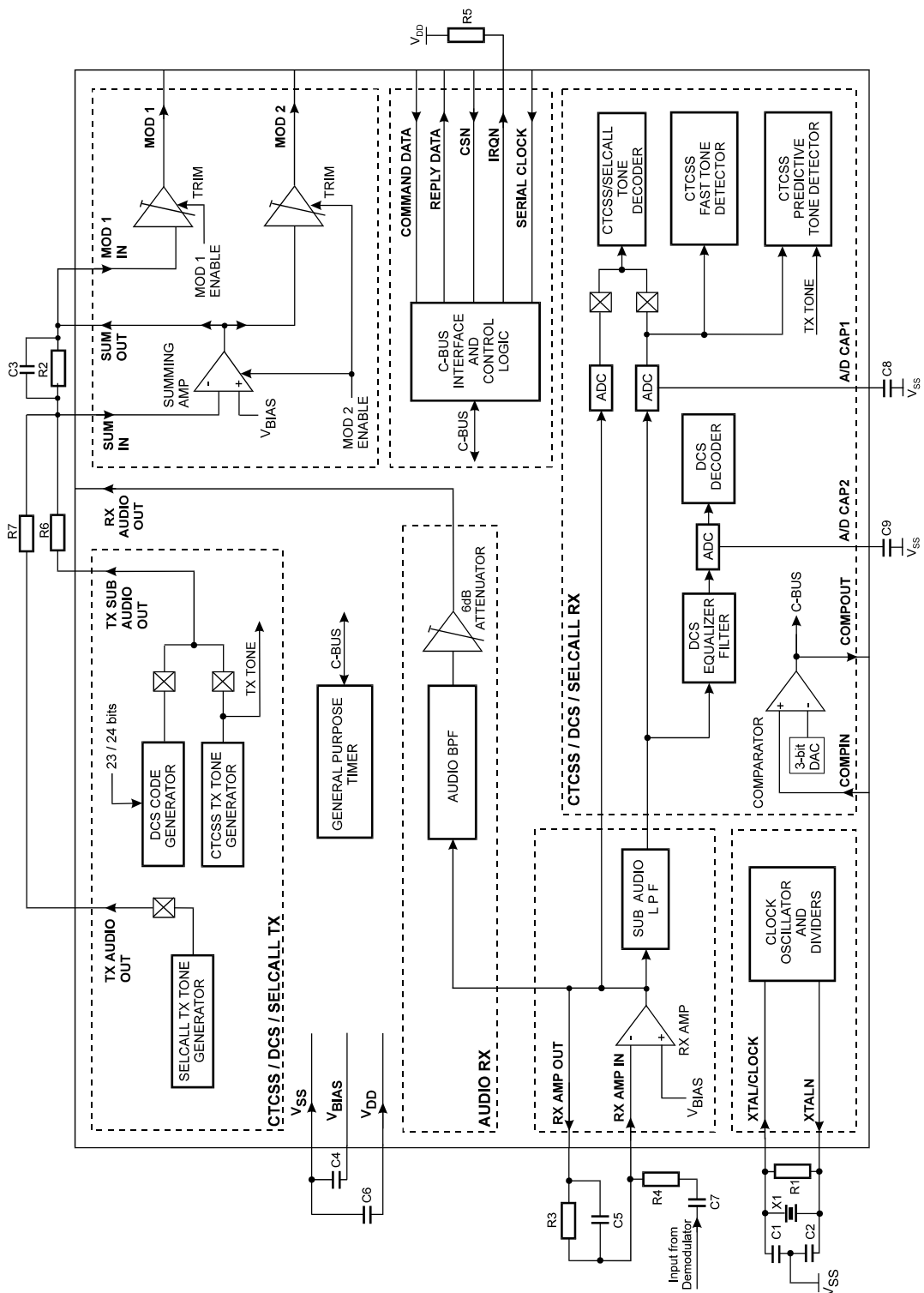

Figure 1 Block Diagram

### 1.3 Signal List

Package D2/D5/P4	Signal		Description
Pin No.	Name	Type	
1	XTALN	O/P	The inverted output of the on-chip oscillator.
2	XTAL/CLOCK	I/P	The input to the on-chip oscillator, for external Xtal circuit or clock.
3	SERIAL CLOCK	I/P	The "C-BUS" serial clock input. This clock, produced by the $\mu$ Controller, is used for transfer timing of commands and data to and from the device. See "C-BUS" Timing Diagram (Figure 4).
4	COMMAND DATA	I/P	The "C-BUS" serial data input from the $\mu$ Controller. Data is loaded into this device in 8-bit bytes, MSB (B7) first, and LSB (B0) last, synchronised to the SERIAL CLOCK. See "C-BUS" Timing Diagram (Figure 4).
5	REPLY DATA	O/P	The "C-BUS" serial data output to the $\mu$ Controller. The transmission of REPLY DATA bytes is synchronised to the SERIAL CLOCK under the control of the CSN input. This 3-state output is held at high impedance when not sending data to the $\mu$ Controller. See "C-BUS" Timing Diagram (Figure 4).
6	CSN	I/P	The "C-BUS" data loading control function: this input is provided by the $\mu$ Controller. Data transfer sequences are initiated, completed or aborted by the CSN signal. See "C-BUS" Timing Diagram (Figure 4).
7	IRQN	O/P	<p>This output indicates an interrupt condition to the <math>\mu</math>Controller by going to a logic "0". This is a "wire-ORable" output, enabling the connection of up to 8 peripherals to 1 interrupt port on the <math>\mu</math>Controller. This pin has a low impedance pulldown to logic "0" when active and a high-impedance when inactive. An external pullup resistor is required.</p> <p>The conditions that cause interrupts are indicated in the IRQ FLAG register and are effective if not masked out by a corresponding bit in the IRQ MASK register.</p>

### 1.3 Signal List (continued)

Package D2/D5/P4	Signal		Description
Pin No.	Name	Type	
8	COMPOUT	O/P	The output of the comparator.
9	COMPIN	I/P	The input to the comparator.
10	A/D CAP 1	O/P	An internal reference voltage for the CTCSS A to D. Decouple to $V_{SS}$ with an external capacitor.
11	A/D CAP 2	O/P	An internal reference voltage for the DCS A to D. Decouple to $V_{SS}$ with an external capacitor.
12	$V_{SS}$	Power	The negative supply rail (ground).
13	$V_{BIAS}$	O/P	A bias line for the internal circuitry, held at $\frac{1}{2} V_{DD}$ . This pin must be decoupled by a capacitor mounted close to the device pins.
14	RX AMP IN	I/P	The inverting input to the Rx input amplifier.
15	RX AMP OUT	O/P	The output of the Rx input amplifier and the input to the audio filter section.
16	RX AUDIO OUT	O/P	Output of the Rx audio filter section.
17	TX AUDIO OUT	O/P	Output of the selcall tone generator.
18	SUM IN	I/P	Input to the audio summing amplifier.
19	SUM OUT	O/P	Output of the audio summing amplifier.
20	MOD1 IN	I/P	Input to MOD1 audio gain control.
21	TX SUB AUDIO OUT	O/P	Output of the CTCSS or DCS Tx tone generator.
22	MOD1	O/P	Output of MOD1 audio gain control.
23	MOD2	O/P	Output of MOD2 audio gain control.
24	$V_{DD}$	Power	The positive supply rail. Levels and voltages are dependent upon this supply. This pin should be decoupled to $V_{SS}$ by a capacitor.

**Notes:** I/P = Input  
O/P = Output

### 1.4 External Components

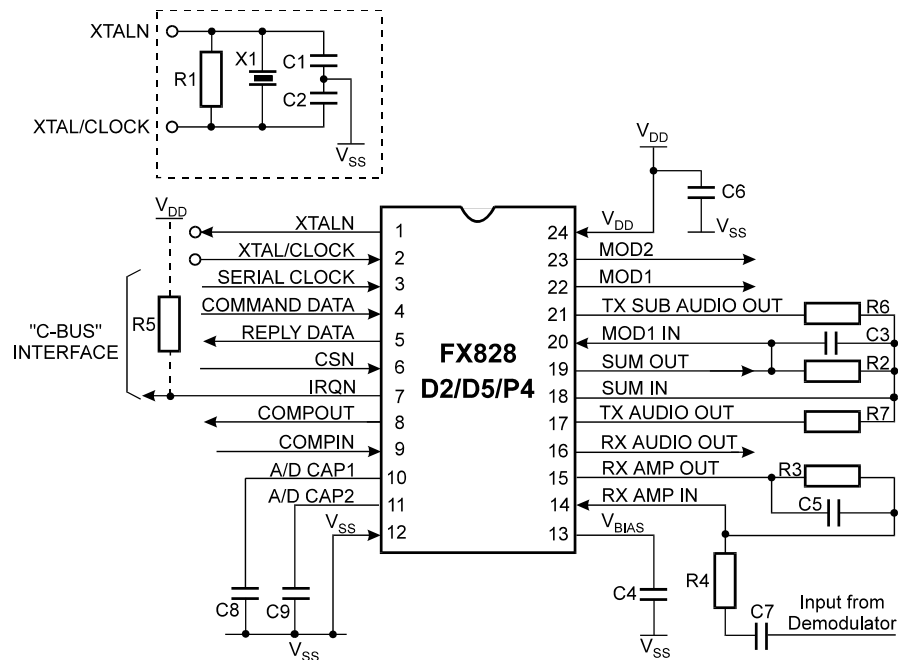

C1	22pF	±20%	R1	1MΩ	±5%	X1	4.032MHz
C2	22pF	±20%	R2	100kΩ	±10%		(tolerance depends upon system requirements)
C3	100pF	±20%	R3	100kΩ	±10%		
C4	0.1µF	±20%	R4	Note 2	±10%		
C5	100pF	±20%	R5	22kΩ	±10%		
C6	0.1µF	±20%	R6	Note 1	±10%		
C7	Note 2	±20%	R7	Note 1	±10%		
C8	0.1µF	±20%					
C9	1.0 to 3.3µF	±20%					

**Notes:** 1. R2, R6, R7 and C3 form the gain components for the Summing Amplifier. R6 and R7 should be chosen as required from the system specification, using the following formula:

$$\text{Tx Sub Audio Gain} = -\frac{R2}{R6}$$

$$\text{Tx Audio Gain} = -\frac{R2}{R7}$$

2. R3, R4, C5 and C7 form the gain components for the Rx Input Amplifier. R4 should be chosen as required by the signal level, using the following formula:

$$\text{Gain} = -\frac{R3}{R4}$$

C7 x R4 should be chosen so as not to compromise the low frequency performance of this product.

**Figure 2 Recommended External Components**

## 1.5 General Description

The FX828 is a signalling encoder/decoder for use in land mobile radio equipment, see Figure 1. The transmitter section of this device has independently controllable tone generators for sub-audio (CTCSS) and inband (Selcall) signalling. It also features a DCS code generator, which may be used in place of the CTCSS tone generator.

The receiver section of the FX828 has a fast/predictive CTCSS tone detector which operates in parallel with a DCS decoder and a CTCSS/Selcall tone decoder. The latter is switchable to perform either CTCSS or Selcall tone decoding of a user-programmable set of up to 15 tones. In the CTCSS mode it performs a more accurate (but slower) analysis of the tones detected by the fast/predictive CTCSS tone detector, which is a single detector that is switchable to provide either a fast response to any CTCSS tone (FAST DETECT mode) or a fast response to a single user-programmed CTCSS tone (PREDICTIVE mode).

Other functions on the FX828 are a comparator with programmable threshold level, a general purpose timer and a summing amplifier with two adjustable gain blocks, which may be used for two point modulation, for example. All FX828 functions are controlled by an external  $\mu$ C over the C-BUS interface, a serial interface designed to reduce interference levels in radio equipment.

### 1.5.1 Software Description

#### Address/Commands

Instructions and data are transferred, via "C-BUS", in accordance with the timing information given in Figure 4.

Instruction and data transactions to and from the FX828 consist of an Address/Command (A/C) byte followed by either:

- (i) a further instruction or data (1 or 2 bytes) or
- (ii) a status or Rx data reply (1 byte)

**8-bit Write Only Registers**

HEX ADDRESS/ COMMAND	REGISTER NAME	BIT 7 (D7)	BIT 6 (D6)	BIT 5 (D5)	BIT 4 (D4)	BIT 3 (D3)	BIT 2 (D2)	BIT 1 (D1)	BIT 0 (D0)
\$01	GENERAL RESET	N/A	N/A	N/A	N/A	N/A	N/A	N/A	N/A
\$80	SIGNALLING CONTROL	SUBAUDIO TX ENABLE	TONE DECODER ENABLE	FAST DETECT ENABLE	0	0	SELCALL TX ENABLE	0	DCS RX ENABLE
\$82	SIGNALLING SET-UP	TONE DECODER BANDWIDTH				FAST CTCSS MODE DETECT/ PREDICTIVE	TONE DECODER MODE	SUBAUDIO TX MODE	DCS 23/24
		MSB BIT 3	BIT 2	BIT 1	LSB BIT 0				
\$85	DCS BYTE 3	DCS BYTE 3							
		OPTIONAL MSB BIT 23	BIT 22	BIT 21	BIT 20	BIT 19	BIT 18	BIT 17	BIT 16
\$86	DCS BYTE 2	DCS BYTE 2							
		BIT 15	BIT 14	BIT 13	BIT 12	BIT 11	BIT 10	BIT 9	BIT 8
\$87	DCS BYTE 1	DCS BYTE 1							
		BIT 7	BIT 6	BIT 5	BIT 4	BIT 3	BIT 2	BIT 1	LSB BIT 0
\$88	GENERAL CONTROL	BPF ENABLE	BPF UN-MUTE	BPF 6dB PAD	MSB DAC BIT 2	DAC BIT 1	LSB DAC BIT 0	GP TIMER ENABLE	GP TIMER RE-CYCLE
\$8B	GENERAL PURPOSE TIMER	GENERAL PURPOSE TIMER							
		MSB BIT 7	BIT 6	BIT 5	BIT 4	BIT 3	BIT 2	BIT 1	LSB BIT 0
\$8E	IRQ MASK	0	GP TIMER IRQ MASK	COMP 0 to 1 IRQ MASK	COMP 1 to 0 IRQ MASK	TONE IRQ MASK	CTCSS FAST IRQ MASK	0	DCS IRQ MASK
\$9C	<i>Reserved for later use</i>								



**16-bit Write Only Registers**

HEX ADDRESS/COMMAND	REGISTER NAME	BIT 7 (D7)	BIT 6 (D6)	BIT 5 (D5)	BIT 4 (D4)	BIT 3 (D3)	BIT 2 (D2)	BIT 1 (D1)	BIT 0 (D0)
\$83	CTCSS TX/ FAST RX FREQUENCY (1)	CTCSS (TX) NOTONE	0	0	CTCSS TX/FAST RX FREQUENCY				
					MSB BIT 12	BIT 11	BIT 10	BIT 9	BIT 8
	CTCSS TX/ FAST RX FREQUENCY (2)	CTCSS TX/FAST RX FREQUENCY							
		BIT 7	BIT 6	BIT 5	BIT 4	BIT 3	BIT 2	BIT 1	LSB BIT 0
\$84	RX TONE PROGRAM (1)	TONE ADDRESS				TONE FREQUENCY			
		MSB BIT 3	BIT 2	BIT 1	LSB BIT 0	MSB BIT 11	BIT 10	BIT 9	BIT 8
	RX TONE PROGRAM (2)	TONE FREQUENCY							
		BIT 7	BIT 6	BIT 5	BIT 4	BIT 3	BIT 2	BIT 1	LSB BIT 0
\$8A	AUDIO CONTROL (1)	0	0	MOD 1 ENABLE	MOD 1				
					MSB BIT 4	BIT 3	BIT 2	BIT 1	LSB BIT 0
	AUDIO CONTROL (2)	0	0	MOD 2 ENABLE	MOD 2				
					MSB BIT 4	BIT 3	BIT 2	BIT 1	LSB BIT 0
\$8D	SELCALL TX (1)	SELCALL NOTONE	0	0	SELCALL TX TONE				
					MSB BIT 12	BIT 11	BIT 10	BIT 9	BIT 8
	SELCALL TX (2)	SELCALL TX TONE							
		BIT 7	BIT 6	BIT 5	BIT 4	BIT 3	BIT 2	BIT 1	LSB BIT 0

## Write Only Register Description

### GENERAL RESET (Hex address \$01)

The reset command has no data attached to it. It sets the device registers into the specific (all powersaved) states as listed below:

REGISTER NAME	HEX ADDRESS	BIT 7 (D7)	BIT 6 (D6)	BIT 5 (D5)	BIT 4 (D4)	BIT 3 (D3)	BIT 2 (D2)	BIT 1 (D1)	BIT 0 (D0)
SIGNALLING CONTROL	\$80	0	0	0	0	0	0	0	0
SELCALL & SUB-AUDIO STATUS	\$81	0	0	0	0	X	X	X	X
SIGNALLING SET-UP	\$82	0	0	0	0	0	0	0	0
CTCSS TX / FAST RX FREQUENCY (1)	\$83	0	0	0	0	0	0	0	0
CTCSS TX / FAST RX FREQUENCY (2)		0	0	0	0	0	0	0	0
RX TONE PROGRAM (1)	\$84	0	0	0	0	0	0	0	0
RX TONE PROGRAM (2)		0	0	0	0	0	0	0	0
DCS BYTE 3	\$85	0	0	0	0	0	0	0	0
DCS BYTE 2	\$86	0	0	0	0	0	0	0	0
DCS BYTE 1	\$87	0	0	0	0	0	0	0	0
GENERAL CONTROL	\$88	0	0	0	0	0	0	0	0
AUDIO CONTROL (1)	\$8A	0	0	0	0	0	0	0	0
AUDIO CONTROL (2)		0	0	0	0	0	0	0	0
GENERAL PURPOSE TIMER	\$8B	0	0	0	0	0	0	0	0
SELCALL TX (1)	\$8D	0	0	0	0	0	0	0	0
SELCALL TX (2)		0	0	0	0	0	0	0	0
IRQ MASK	\$8E	0	0	0	0	0	0	0	0
IRQ FLAG	\$8F	0	0	0	0	0	0	0	0

X = undefined

### SIGNALLING CONTROL Register (Hex address \$80)

This register is used to control the functions of the device as described below:

#### SUBAUDIO TX ENABLE (Bit 7)

Bit 7 should be set to "1" to enable the CTCSS/DCS subaudio transmitter. The subaudio Tx type will depend on the state of the SUBAUDIO TX MODE (Bit 1 SIGNALLING SET-UP Register \$82).

#### TONE DECODER ENABLE (Bit 6)

Bit 6 should be set to "1" to enable the CTCSS/Selcall tone decoder or the DCS decoder. Note: See also Bit 0 for DCS decoder operation.

Bits 7 and 6 should not both be set to "1" when Bit 0 is set to "1" because the DCS function is half-duplex only.

#### CTCSS FAST DETECT ENABLE (Bit 5)

When this bit is "1", the FAST CTCSS DETECT or FAST CTCSS PREDICTIVE mode is enabled, depending upon the setting of FAST CTCSS MODE (Bit 3 SIGNALLING SET-UP Register, \$82). When this bit is "0", both FAST CTCSS DETECT and FAST CTCSS PREDICTIVE tone detectors are disabled.

#### SELCALL TX ENABLE (Bit 2)

When this bit is "1" the Selcall transmitter is enabled. When this bit is "0" the Selcall transmitter is disabled and powersaved.

#### DCS RX ENABLE (Bit 0)

When this bit is "1" and Bit 6 is "1", the DCS decoder is enabled. When this bit is "0" the DCS decoder is disabled.

The DCS decoder and the subaudio (CTCSS or DCS) transmitter should not be enabled at the same time.

#### (Bits 4, 3, and 1)

Reserved for future use. These bits should be set to "0".

**SIGNALLING SET-UP Register (Hex address \$82)**

This register is used to define the signalling parameters, as described below:

**TONE DECODER  
BANDWIDTH  
(Bits 7, 6, 5 and 4)**

These four bits set the bandwidth of the CTCSS/Selcall tone decoder according to the table below:

	Bit 7	Bit 6	Bit 5	Bit 4	BANDWIDTH	
					Will Decode	Will Not Decode
Recommended for CTCSS	1	0	0	0	±1.1%	±2.4%
Recommended for CCIR	1	0	0	1	±1.3%	±2.7%
	1	0	1	0	±1.6%	±2.9%
	1	0	1	1	±1.8%	±3.2%
	1	1	0	0	±2.0%	±3.5%
	1	1	0	1	±2.2%	±3.7%
Recommended for ZVEI	1	1	1	0	±2.5%	±4.0%
	1	1	1	1	±2.7%	±4.2%

**FAST CTCSS MODE  
(Bit 3)**

When CTCSS FAST DETECT ENABLE (Bit 5 SIGNALLING CONTROL Register, \$80) is "1", this bit selects the FAST CTCSS DETECT or the FAST CTCSS PREDICTIVE mode, according to the table below:

DETECT/ PREDICTIVE Bit 3	Function
0	DETECT mode
1	PREDICTIVE mode

If the CTCSS FAST DETECT ENABLE bit is "0" then both modes are deselected.

**TONE DECODER  
MODE  
(Bit 2)**

When this bit is "1" the CTCSS/Selcall tone decoder is set to detect inband (Selcall) tones. When this bit is "0" the tone decoder is set to detect subaudio (CTCSS) tones.

**SUBAUDIO TX MODE  
(Bit 1)**

When this bit is "1" the subaudio transmitter will be set to transmit DCS signals, if enabled. When this bit is "0" the subaudio transmitter will be set to transmit CTCSS signals, if enabled.

**DCS 23/24  
(Bit 0)**

When this bit is "1" the DCS transmitter and decoder are configured for a 23-bit code. When this bit is "0" they are configured for a 24-bit code.

**DCS BYTE 3 Register (Hex address \$85)**

**DCS BYTE 2 Register (Hex address \$86)**

**DCS BYTE 1 Register (Hex address \$87)**

These three bytes set the code that is transmitted or received in the DCS mode. The LSB bit 0 of the DCS BYTE 1 is transmitted first and the last bit is the MSB bit 23 of DCS BYTE 3 in the 24-bit mode or bit 22 in the 23-bit mode.

**GENERAL CONTROL Register (Hex address \$88)**

This register is used to control the functions of the device as described below:

**BPF ENABLE (Bit 7)** When this bit is "1" the audio band-pass filter is enabled. When this bit is "0" the audio band-pass filter is disabled (powersaved).

**BPF UN-MUTE (Bit 6)** When this bit is "1" the audio band-pass filter output is switched to the RX AUDIO OUT pin. When this bit is "0" the output of the filter is disconnected from RX AUDIO OUT, which is then in a high impedance state.

This control, along with BPF ENABLE, allows the filter to power up and settle internally before switching the output on, to avoid clicks when coming out of powersave.

**BPF 6dB PAD (Bit 5)** When this bit is "1" a 6dB attenuator is inserted into the output of the audio band-pass filter. When this bit is "0" the output of the audio band-pass filter is not attenuated.

**DAC (Bits 4, 3 and 2)** These three bits set the level of the digital to analogue converter that feeds the negative input of the comparator. The DAC can be set to one of eight levels equally spaced between  $V_{SS}$  and  $V_{BIAS}$ , not including  $V_{SS}$ , but including  $V_{BIAS}$ , i.e. with a 5V supply, the lowest level would be 312.5mV set by "000" in bits 2, 3 and 4 and the highest level would be 2.5V set by "111" in bits 2, 3 and 4.

**TIMER ENABLE (Bit 1)** When this bit goes to a "1" the general purpose timer is restarted and its internal register is re-loaded from the value specified in the GENERAL PURPOSE TIMER Register (Hex address \$8B). It will then count down from the count held in its internal register. When this bit is "0" the count down is disabled and the last pre-programmed value is retained in the timer's internal register.

**TIMER RE-CYCLE (Bit 0)** When this bit is "1" the general purpose timer will re-load its internal register from the value specified in the GENERAL PURPOSE TIMER Register (Hex Address \$8B) when the count in the internal register reaches zero (i.e. the timeout has expired). It then restarts the count down, so that the timer continuously cycles.

When this bit is "0" the general purpose timer will stop when the count in the internal register reaches zero (i.e. the timeout has expired). The timer can only be restarted by reloading a value into the GENERAL PURPOSE TIMER Register (Hex address \$8B).

If this bit is switched from "1" to "0" whilst the timer is enabled then the timer will complete the present count before stopping.

**GENERAL PURPOSE TIMER (GPT) Register (Hex address \$8B)**

This register is used to preset the value of a countdown timer. Once a binary value has been loaded into this register, it will be automatically transferred to an internal register within the timer. This internal register is then decremented at each count interval (1ms) until it reaches zero. On reaching zero, the GPT IRQ FLAG in the IRQ FLAG Register (Hex address \$8F) is set to "1". An interrupt is generated on the IRQN pin if the GPT IRQ MASK in the IRQ MASK Register (Hex address \$8E) is "1" otherwise the GPT IRQ FLAG remains set to "1" and no interrupt is generated.

When the internal register has reached a count of zero, the action of the timer depends on the setting of the TIMER RE-CYCLE bit in the GENERAL CONTROL Register (Hex address \$88). If the TIMER RE-CYCLE bit is "1" then the timer will re-load the countdown value from the GENERAL PURPOSE TIMER Register and restart the countdown from this value. If the TIME RE-CYCLE bit is "0" then the timer will stop and no further action or timer interrupts will take place until the GENERAL PURPOSE TIMER Register is re-loaded. Loading the GENERAL PURPOSE TIMER with "0" will cause the timer circuitry to be disabled (i.e. powersaved).

### IRQ MASK Register (Hex address \$8E)

This register is used to control the interrupts (IRQs) as described below:

<b>(Bits 7 and 1)</b>	Reserved for future use. These should be set to "0".
<b>GPT IRQ MASK (Bit 6)</b>	When this bit is set to "1" it enables an interrupt that occurs when GPT IRQ FLAG (Bit 6, IRQ FLAG Register, \$8F) changes from "0" to "1". When this bit is "0" the interrupt is masked.
<b>COMP 0 to 1 IRQ MASK (Bit 5)</b>	When this bit is set to "1" it enables an interrupt that occurs when the comparator output goes from "0" to "1". When this bit is set to "0" the interrupt is masked.
<b>COMP 1 to 0 IRQ MASK (Bit 4)</b>	When this bit is set to "1" it enables an interrupt that occurs when the comparator output goes from "1" to "0". When this bit is set to "0" the interrupt is masked.
<b>TONE IRQ MASK (Bit 3)</b>	When this bit is set to "1" it enables an interrupt that occurs when the TONE IRQ FLAG (Bit 3, IRQ FLAG Register, \$8F) changes from "0" to "1". When this bit is "0" the interrupt is masked.
<b>CTCSS FAST IRQ MASK (Bit 2)</b>	When this bit is set to "1" it enables an interrupt that occurs when the CTCSS FAST IRQ FLAG (Bit 2, IRQ FLAG Register, \$8F) changes from "0" to "1". When this bit is "0" the interrupt is masked.
<b>DCS IRQ MASK (Bit 0)</b>	When this bit is set to "1" it enables an interrupt that occurs when the DCS DECODE/NO DECODE FLAG (Bit 7, SELCALL & SUB-AUDIO STATUS Register \$81) changes state. When this bit is set to "0" the interrupt is masked.

### CTCSS TX/FAST RX FREQUENCY Register (Hex address \$83)

This is a 16-bit register. Byte (1) is sent first. When the CTCSS fast detector is enabled, the bits 0 to 12 define the receive frequency the fast predictive detector is looking for according to the formula below.

When the CTCSS transmitter is enabled, the bits 0 to 12 control the frequency of the transmitted CTCSS tones according to the formula below.

When the fast detector and the transmitter are both enabled, the bits 0 to 12 define the receive frequency the fast predictive detector is looking for and the frequency of the transmitted tone according to the formula below (i.e. Tx tone = predictive tone).

$$A = \frac{f_{XTAL} \text{ (Hz)}}{16 \times f_{TONE} \text{ (Hz)}}$$

where A is the binary number programmed into the 13 bits.

When Bit 7 in byte (1) is set to "1" the tone output is set at  $V_{BIAS}$  or NOTONE without regard to the number "A" programmed. When Bit 7 is "0" the programmed tone is set on the output. Programming the bits 0 to 12 to "0" puts the Tx into powersave and the output goes to  $V_{BIAS}$ . Powersave is also achieved by disabling the SUBAUDIO Tx and the CTCSS FAST DETECT.

**RX TONE PROGRAM Register (Hex address \$84)**

This is a 16-bit register. Byte (1) is sent first. The two bytes are used to program the centre frequencies of up to 15 tones in either the audio or sub-audio band that will be decoded by the receiver.

Each tone is identified by its address in bits 7, 6, 5 and 4 of byte (1). The remaining 12 bits contain the data representing the tone frequency according to the formula below. If a tone is not required the 12 bits should be set to zero.

Byte 1								Byte 2							
Bit 7	Bit 6	Bit 5	Bit 4	Bit 3	Bit 2	Bit 1	Bit 0	Bit 7	Bit 6	Bit 5	Bit 4	Bit 3	Bit 2	Bit 1	Bit 0
0	0	0	0	<----- N ----->				<----- R ----->							
0	0	0	1	N is the binary representation of the following decimal number (n):  SUBAUDIO (CTCSS) $n = \text{INT} (948982 \times f_{TONE} / f_{XTAL})$				R is the nearest 6-bit binary representation of (r), where:  SUBAUDIO (CTCSS) $r = ((237245/f_{XTAL}) - (n/(4 \times f_{TONE}))) \times 8400$							
0	0	1	0												
0	0	1	1												
0	1	0	0												
0	1	0	1												
0	1	1	0												
0	1	1	1												
1	0	0	0												
1	0	0	1												
1	0	1	0												
1	0	1	1	INBAND (SELCALL) $n = \text{INT} (83036 \times f_{TONE} / f_{XTAL})$				INBAND (SELCALL) $r = ((20759/f_{XTAL}) - (n/(4 \times f_{TONE}))) \times 96000$							
1	1	0	0												
1	1	0	1												
1	1	1	0												

Example: To program 100Hz when using the recommended 4.032MHz Xtal in SUBAUDIO (CTCSS) mode.

$$\begin{aligned}
 n &= \text{INT} (948982 \times 100 / 4.032 \times 10^6) \\
 &= \text{INT} (23.536) = 23 \\
 N &= 010111 \text{ (binary)}
 \end{aligned}$$

$$\begin{aligned}
 r &= ((237245 / 4.032 \times 10^6) - (23 / (4 \times 100))) \times 8400 \\
 &= 11.26 \text{ (round up if exactly halfway)}
 \end{aligned}$$

$$\begin{aligned}
 R &= 11 \\
 &= 001011 \text{ (binary)}
 \end{aligned}$$

Thus the 12-bit code is 010111001011

The Hex address represented by bits 7, 6, 5 and 4 in byte (1) is used as the code to indicate which tone has been decoded. This code appears in bits 3, 2, 1 and 0 of the SELCALL and SUB-AUDIO STATUS Register (Hex address \$81). The 15 programmed tones use Hex addresses \$0 - \$E.

**AUDIO CONTROL Register (Hex address \$8A)**

This is a 16-bit register. Byte (1) is sent first. Bits 0 - 5 of the first byte in this register are used to set the attenuation of the Modulator 1 amplifier and bits 0 - 5 of the second byte in this register are used to set the attenuation of the Modulator 2 amplifier, according to the tables below:

BYTE 1							BYTE 2						
5	4	3	2	1	0	Mod. 1 Attenuation	5	4	3	2	1	0	Mod. 2 Attenuation
0	X	X	X	X	X	Disabled ( $V_{BIAS}$ )	0	X	X	X	X	X	Disabled ( $V_{BIAS}$ )
1	0	0	0	0	0	>40dB	1	0	0	0	0	0	>40dB
1	0	0	0	0	1	12.0dB	1	0	0	0	0	1	6.0dB
1	0	0	0	1	0	11.6dB	1	0	0	0	1	0	5.8dB
1	0	0	0	1	1	11.2dB	1	0	0	0	1	1	5.6dB
1	0	0	1	0	0	10.8dB	1	0	0	1	0	0	5.4dB
1	0	0	1	0	1	10.4dB	1	0	0	1	0	1	5.2dB
1	0	0	1	1	0	10.0dB	1	0	0	1	1	0	5.0dB
1	0	0	1	1	1	9.6dB	1	0	0	1	1	1	4.8dB
1	0	1	0	0	0	9.2dB	1	0	1	0	0	0	4.6dB
1	0	1	0	0	1	8.8dB	1	0	1	0	0	1	4.4dB
1	0	1	0	1	0	8.4dB	1	0	1	0	1	0	4.2dB
1	0	1	0	1	1	8.0dB	1	0	1	0	1	1	4.0dB
1	0	1	1	0	0	7.6dB	1	0	1	1	0	0	3.8dB
1	0	1	1	0	1	7.2dB	1	0	1	1	0	1	3.6dB
1	0	1	1	1	0	6.8dB	1	0	1	1	1	0	3.4dB
1	0	1	1	1	1	6.4dB	1	0	1	1	1	1	3.2dB
1	1	0	0	0	0	6.0dB	1	1	0	0	0	0	3.0dB
1	1	0	0	0	1	5.6dB	1	1	0	0	0	1	2.8dB
1	1	0	0	1	0	5.2dB	1	1	0	0	1	0	2.6dB
1	1	0	0	1	1	4.8dB	1	1	0	0	1	1	2.4dB
1	1	0	1	0	0	4.4dB	1	1	0	1	0	0	2.2dB
1	1	0	1	0	1	4.0dB	1	1	0	1	0	1	2.0dB
1	1	0	1	1	0	3.6dB	1	1	0	1	1	0	1.8dB
1	1	0	1	1	1	3.2dB	1	1	0	1	1	1	1.6dB
1	1	1	0	0	0	2.8dB	1	1	1	0	0	0	1.4dB
1	1	1	0	0	1	2.4dB	1	1	1	0	0	1	1.2dB
1	1	1	0	1	0	2.0dB	1	1	1	0	1	0	1.0dB
1	1	1	0	1	1	1.6dB	1	1	1	0	1	1	0.8dB
1	1	1	1	0	0	1.2dB	1	1	1	1	0	0	0.6dB
1	1	1	1	0	1	0.8dB	1	1	1	1	0	1	0.4dB
1	1	1	1	1	0	0.4dB	1	1	1	1	1	0	0.2dB
1	1	1	1	1	1	0dB	1	1	1	1	1	1	0dB

X = don't care

**MOD1 ENABLE (Bit 5, first byte)** When this bit is "1" the MOD1 attenuator is enabled.  
When this bit is "0" the MOD1 attenuator is disabled (i.e. powersaved).

**MOD2 ENABLE (Bit 5, second byte)** When this bit is "1" the MOD2 attenuator and the SUMMING AMP are enabled.  
When this bit is "0" they are both disabled (i.e. powersaved).

**(Bits 7 and 6, first and second bytes)** Reserved for future use. These should be set to "0".

**SELCALL TX Register (Hex address \$8D)**

This is a 16-bit register. Byte (1) is sent first.

When the SELCALL transmitter is enabled, bits 0 to 12 control the frequency of the transmitted SELCALL tones according to the formula overleaf:

$$A = \frac{f_{XTAL} \text{ (Hz)}}{4 \times f_{TONE} \text{ (Hz)}}$$

where A is the binary number programmed into the 13 bits.

When Bit 7 (in the first 8 bits) is set to "1" the tone output is set at  $V_{BIAS}$  or NOTONE without regard to the number "A" programmed. When Bit 7 is "0" the programmed tone is set on the output. Programming the bits 0 to 12 to "0" puts the Tx into powersave and the output goes to  $V_{BIAS}$ . Powersave is also achieved by disabling the SELCALL Tx.

### 8-bit Read Only Registers

HEX ADDRESS/COMMAND	REGISTER NAME	BIT 7 (D7)	BIT 6 (D6)	BIT 5 (D5)	BIT 4 (D4)	BIT 3 (D3)	BIT 2 (D2)	BIT 1 (D1)	BIT 0 (D0)
\$81	SELCALL & SUB-AUDIO STATUS	DCS DECODE/NO DECODE	CTCSS FAST TONE	0	TONE DECODE	RX TONE			
						MSB BIT 3	BIT 2	BIT 1	LSB BIT 0
\$8F	IRQ FLAG	0	GP TIMER IRQ FLAG	COMP 0 to 1 IRQ FLAG	COMP 1 to 0 IRQ FLAG	TONE IRQ FLAG	CTCSS FAST IRQ FLAG	0	DCS IRQ FLAG

### Read Only Register Description

#### SELCALL and SUB-AUDIO STATUS Register (Hex address \$81)

This register is used to indicate the status of the device as described below:

#### DCS DECODE/NO DECODE (Bit 7)

When the DCS decoder is enabled this bit is continuously updated with the result. A "1" indicates a successful decode (with 3 or less errors). A "0" indicates a failure to decode.

#### CTCSS FAST TONE (Bit 6)

When Bit 5 in the SIGNALLING CONTROL Register and Bit 3 in the SIGNALLING SET-UP Register are set to enable FAST CTCSS DETECT mode, this bit will be set to "1" if a periodic tone is detected. If no periodic tone is detected this bit will be "0".

When bits 5 and 3 are set to enable FAST CTCSS PREDICTIVE mode, this bit will be set to "1" if a periodic tone that matches the frequency programmed in the CTCSS TX/FAST RX FREQUENCY Register is detected. If no match is found this bit will be "0".

When Bit 5 in the SIGNALLING CONTROL Register is set to "0" this bit will be "0".

#### (Bit 5)

Reserved for future use. This will be set to "0" but should be ignored by the user's software.

#### TONE DECODE (Bit 4)

This bit indicates the status of the tone decoder. A "1" indicates a tone has been detected (TONE DECODE) and a "0" indicates the loss of the tone (NOTONE).



TONE DECODE means that a tone has been decoded and its characteristics are defined by the bandwidth (See SIGNALLING SET-UP Register bits 7, 6, 5 and 4) and the RX TONE number (See SELCALL and SUB-AUDIO STATUS Register bits 3, 2, 1 and 0).

When Bit 6 in the SIGNALLING CONTROL Register is set to "0" the TONE DECODE bit 4 will be set to "0".

Identification of a valid tone which is not in the pre-programmed list of up to 15 tones will cause the decoder to move to the TONE DECODE state with the RX TONE address of "1111" in bits 3, 2, 1 and 0; indicating a valid, but unrecognised, tone. Loss of tone, will cause the NOTONE timer to be started. If loss of tone continues for the duration of the timeout period, then the decoder will move to NOTONE state and the identification of pre-programmed tones will start again. The time-out period is not user-adjustable.

**RX TONE  
(Bits 3, 2, 1 and 0)**

These four bits hold a Hex number from \$0 to \$F. Numbers \$0 to \$E represent the address of the tone decoded according to the tones programmed in the RX TONE PROGRAM Register, \$84. The Hex number \$F indicates the presence of any tone that is not described by DECODER BANDWIDTH (Bits 7, 6, 5 and 4, SIGNALLING SET-UP Register, \$82) and FREQUENCY (Bits 11 - 0, RX TONE PROGRAM Register, \$84).

**IRQ FLAG Register (Hex address \$8F)**

This register is used to indicate when the device requires attention as below:

<b>(Bits 7 and 1)</b>	Reserved for future use. These will be set to "0" but should be ignored by user's software.
<b>GPT IRQ FLAG (Bit 6)</b>	When the general purpose timer has reached zero in its internal register, this bit will be set to "1" to indicate the timeout has expired. This bit is cleared to "0" by a read of the IRQ FLAG Register (Hex address \$8F).
<b>COMP 0 to 1 IRQ FLAG (Bit 5)</b>	When the comparator output goes from "0" to "1" (i.e. when the input voltage is above the DAC output voltage) this bit will be set to "1" and an interrupt generated (if bit 5 of the IRQ MASK Register \$8E is set to "1"). This bit is set to "0" when the IRQ FLAG Register \$8F is read.
<b>COMP 1 to 0 IRQ FLAG (Bit 4)</b>	When the comparator output goes from "1" to "0" this bit will be set to "1" and an interrupt generated (if bit 4 of the IRQ MASK Register \$8E is set to "1"). This bit is set to "0" when the IRQ FLAG Register \$8F is read.
<b>TONE IRQ FLAG (Bit 3)</b>	When RX TONE DECODE (Bit 4, SELCALL and SUB-AUDIO STATUS Register, \$81) or Rx TONE (the decoded 4 bit tone address in Register \$81) changes state this bit will be set to "1". This bit is cleared to "0" by a read of the IRQ FLAG Register (Hex address \$8F).
<b>CTCSS FAST IRQ FLAG (Bit 2)</b>	When CTCSS FAST TONE (Bit 6, SELCALL and SUB-AUDIO STATUS Register, \$81) changes state this bit will be set to "1". This bit is cleared to "0" by a read of the IRQ FLAG Register (Hex address \$8F).
<b>DCS IRQ FLAG (Bit 0)</b>	When DCS DECODE/NO DECODE (Bit 7 SELCALL and SUB-AUDIO STATUS Register, \$81) changes state this bit will be set to "1". This bit is cleared to "0" by a read of the IRQ FLAG Register (Hex address \$8F).

The flow chart shows the following modes of operation for the example below:

1. Decode )
2. Decode and Fast Detect ) e.g. Address 3 = 100Hz, bandwidth = ±2.7%, interrupt enabled
3. Decode & Fast Predictive )
4. Transmit, e.g. Tx = 100Hz

Note: \$8X is the Hex address/command.

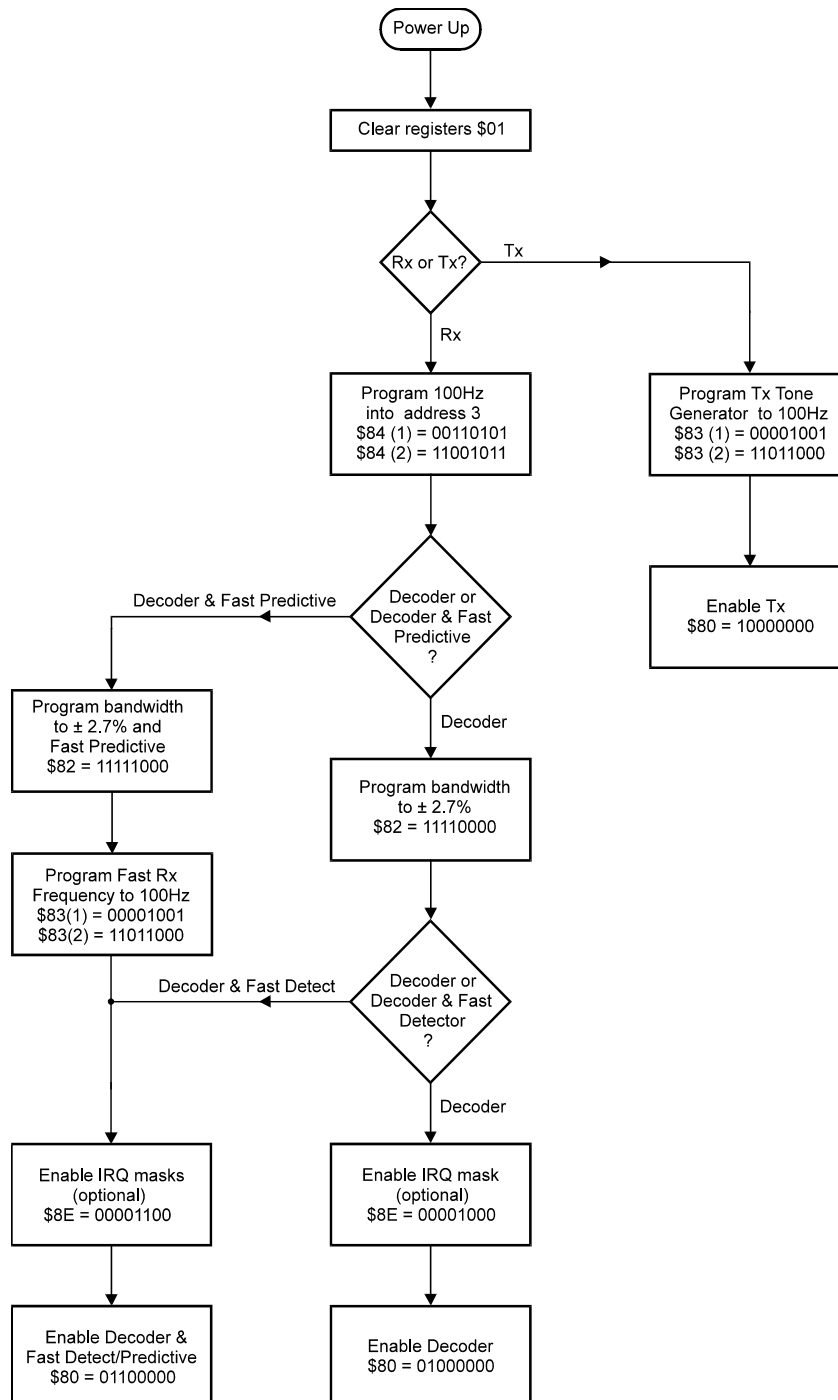

The flow chart shows the decoder, fast detect/fast predictive and transmitter enabled with the following example.

1. Tx tone generator = 100Hz
2. Decoder programmed with 100Hz in address 3
3. Bandwidth setting =  $\pm 2.7\%$
4. Interrupt enabled

Note: \$8X is the Hex address/command.

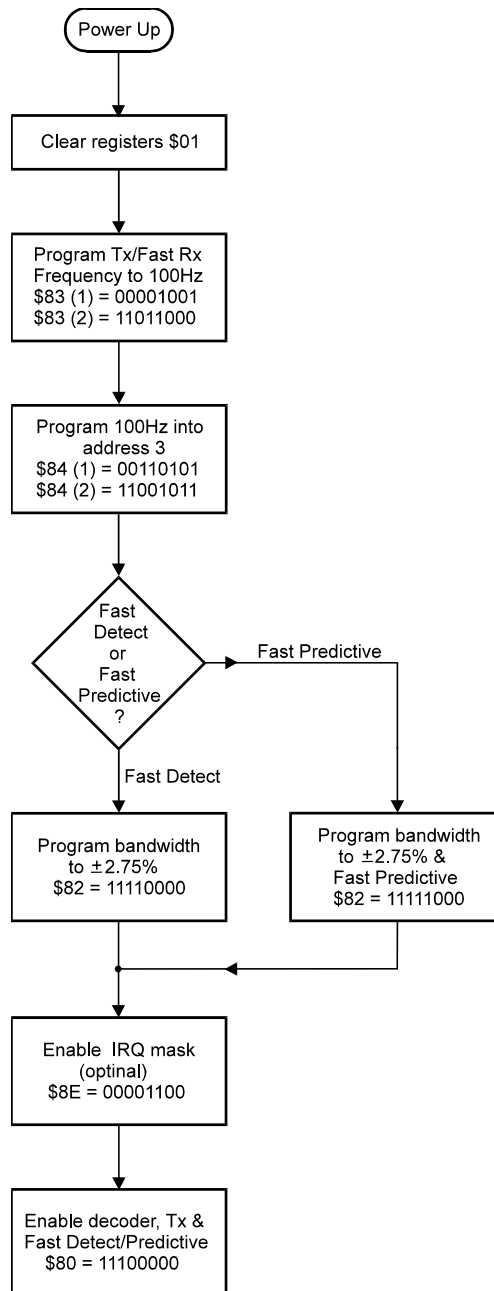

## 1.6 Application Notes

### 1.6.1 General

The FX828 is intended for use in radio systems where signalling is required for functions such as trunking, control, selective calling or group calling.

The CTCSS fast/predictive detector is useful for the detection of occupied channels indicating either the presence of any sub-audio tone, or range of tones, depending if it is set in fast detect or predictive mode. This will increase the efficiency of scanning and trunking systems, reducing the average time allocated to assessing each channel.

The facility to decode any of up to 15 programmed tones allows the use of tones for various signalling functions such as masking a free channel or identifying sub groups within a user's groups.

Adjustable decoder bandwidths permit certainty and signal to noise performance to be traded when congestion or range limits the system performance.

### 1.6.2 Transmitters

**The CTCSS transmitter** is enabled with Bit 7 in the SIGNALLING CONTROL Register (\$80) and bit 1 in the SIGNALLING SET UP Register (\$82).

The Tx frequency is set using Bit 0 to Bit 12 in the CTCSS TX/FAST RX FREQUENCY Register (\$83) using the formula below:

$$A = \frac{f_{XTAL} \text{ (Hz)}}{16 \times f_{TONE} \text{ (Hz)}}$$

where A is the binary number programmed into the 13 bits.

When Bit 7 (in the first 8 bits) is set to "1" the tone output is set at  $V_{BIAS}$  or NOTONE without regard to the number "A" programmed. When Bit 7 is "0" the programmed tone is set on the output. Programming the bits 0 to 12 to "0" puts the Tx into powersave and the output goes to  $V_{BIAS}$ . Powersave is also achieved by disabling the SUBAUDIO Tx and the CTCSS FAST DETECT (Bits 7 and 5 in the SIGNALLING CONTROL Register \$80).

**The SELCALL transmitter** is enabled with Bit 2 in the SIGNALLING CONTROL Register (\$80).

The Tx frequency is set using Bit 0 to Bit 12 in the SELCALL TX Register (\$8D) using the formula below:

$$A = \frac{f_{XTAL} \text{ (Hz)}}{4 \times f_{TONE} \text{ (Hz)}}$$

where A is the binary number programmed into the 13 bits.

When Bit 7 (in the first 8 bits) is set to "1" the tone output is set at  $V_{BIAS}$  or NOTONE without regard to the number "A" programmed. When Bit 7 is "0" the programmed tone is set on the output. Programming the bits 0 to 12 to "0" puts the Selcall Tx into powersave and the output goes to  $V_{BIAS}$ . Powersave is also achieved by disabling the SELCALL TX ENABLE (Bit 2 in the SIGNALLING CONTROL Register \$80).

**The DCS transmitter** is enabled by setting Bit 7 to "1" in the SIGNALLING CONTROL Register (\$80) having already set Bit 1 to "1" in the SIGNALLING SET UP Register (\$82). Note that Bit 0 of this SIGNALLING SET UP Register is used to select either 23-bit or 24-bit mode.

The Tx data is set in the DCS BYTE 3, DCS BYTE 2 and DCS BYTE 1 Registers (\$85, \$86 and \$87).

Note that the DCS transmitter produces an inverted output. When the signal is fed through the summing amp, in an inverting configuration, the correct polarity of the DCS signal will be restored (the modulator gain blocks do not invert).

### 1.6.3 Receiver (CTCSS/Selcall Decoder)

The CTCSS/Selcall decoder should first be set up according to the desired characteristics. This entails setting the TONE DECODER MODE Bit 2 of the SIGNALLING SET UP Register (\$82), and setting the TONE decoder bandwidth in the SIGNALLING SET-UP Register (\$82), also programming the centre frequencies of the desired tones in the RX TONE PROGRAM Register (\$84). (It can hold up to 15 different tones). Any tone can be in any location. When the device is decoding, the tones are scanned in the sequence of their location, i.e. \$0 first and \$E last. Once a tone is detected the remaining tones are not checked. Therefore if two tones are close enough in frequency for their bandwidths to overlap then the one in the lowest location will be detected.

The TONE IRQ MASK in the IRQ MASK Register (\$8E) should also be set as required.

The TONE DECODER ENABLE in the SIGNALLING CONTROL Register (\$80) should then be set to "1". Whilst in the CTCSS/Selcall decoder mode the fast/predictive detector may be enabled (see below) (Bit 5 in the SIGNALLING CONTROL Register \$80).

When the CTCSS/Selcall decoder detects a change in its present state an IRQ will be generated and Bit 3 of the IRQ FLAG Register (\$8F) will indicate this. To reduce the likelihood of false or missed CTCSS decodes, it is recommended that pre-emphasis and external audio pass-band filtering (300 to 3000Hz, for example) be used in the Tx path.

The change that occurred can be read from Bit 4 of the SELCALL and SUB-AUDIO STATUS Register (\$81) and if a tone is indicated by these bits then the number of that tone can be read from Bits 3, 2, 1 and 0 of the same register.

### 1.6.4 Receiver (CTCSS Fast/Predictive Detector)

This is used for detecting, in the fastest possible time, that sub-audio tones are present on the Rx channel. Response time is optimised for speed at the expense of frequency resolution.

It can operate in parallel to the CTCSS/Selcall decoder. It is enabled using Bit 5 of the SIGNALLING CONTROL Register (\$80). It has an IRQ which may be unmasked with Bit 2 of the IRQ MASK Register (\$8E). The FAST CTCSS MODE DETECT/PREDICTIVE Bit 3 in the SIGNALLING SET-UP Register (\$82) allows for one of two alternatives in the FAST mode. In DETECT mode it will detect any periodic tone in the sub-audio band and when in PREDICTIVE mode it will detect specific tones determined by the frequency set in the CTCSS TX/FAST RX FREQUENCY Register (\$83) and the fixed PREDICTIVE mode bandwidth. Successful detection is indicated by the CTCSS FAST IRQ FLAG Bit 2 in the IRQ FLAG Register (\$8F), and the CTCSS FAST TONE Bit 6 in the SELCALL and SUB-AUDIO STATUS Register (\$81).

### 1.6.5 Receiver (DCS Decoder)

The incoming signal is matched with the DCS code programmed into the DCS BYTE 1/2/3 Registers. When the DCS decoder is enabled, the DCS DECODE/NO DECODE FLAG in Bit 7 of the SELCALL and SUB-AUDIO STATUS Register (\$81) will be set if the decode is successful (3 or fewer errors). A "0" flag indicates a failure to decode. This flag is updated for every bit of the incoming signal.

In order to detect the DCS turn-off code (134Hz), the CTCSS Tone Decoder should also be enabled and programmed with this value. Once detected this will cause a CTCSS tone decode interrupt; the receiver audio output should then be muted.

### 1.6.6 General Purpose Timer (GPT)

This may be used in conjunction with the CTCSS/Selcall decoder to form part of the decode algorithm or as a timer for any other purpose. It has an 8-bit value in the GENERAL PURPOSE TIMER Register (\$8B) set in units of 1msec, an IRQ FLAG in Bit 6 of the IRQ FLAG Register (\$8F) and an IRQ MASK in Bit 6 of the IRQ MASK Register (\$8E).

### 1.6.7 Full Duplex Modes

The only functions that must operate as half duplex are:

DCS Tx	or	DCS Rx
DCS Tx	or	CTCSS Tx
CTCSS decode	or	SELCALL decode

All other functions are totally independent and therefore a full duplex CTCSS or full duplex SELCALL along with many other combinations are possible.

### 1.6.8 Tx / Fast Rx Tone Table : CTCSS

The following table lists the commonly used CTCSS tones and the corresponding values for programming the transmitter frequency / fast predictive frequency register (Hex address \$83).

Freq. (Hz)	Byte 1 (hex)	Byte 2 (hex)	Freq. (Hz)	Byte 1 (hex)	Byte 2 (hex)	Freq. (Hz)	Byte 1 (hex)	Byte 2 (hex)
<b>67.0</b>	E	B1	<b>114.8</b>	8	93	<b>186.2</b>	5	49
<b>69.3</b>	E	34	<b>118.8</b>	8	49	<b>189.9</b>	5	2F
<b>71.9</b>	D	B1	<b>123.0</b>	8	1	<b>192.8</b>	5	1B
<b>74.4</b>	D	3B	<b>127.3</b>	7	BC	<b>196.6</b>	5	2
<b>77.0</b>	C	C9	<b>131.8</b>	7	78	<b>199.5</b>	4	EF
<b>79.7</b>	C	5A	<b>136.5</b>	7	36	<b>203.5</b>	4	D6
<b>82.5</b>	B	EF	<b>141.3</b>	6	F7	<b>206.5</b>	4	C4
<b>85.4</b>	B	87	<b>146.2</b>	6	BC	<b>210.7</b>	4	AC
<b>88.5</b>	B	1F	<b>151.4</b>	6	80	<b>218.1</b>	4	83
<b>91.5</b>	A	C2	<b>156.7</b>	6	48	<b>225.7</b>	4	5D
<b>94.8</b>	A	62	<b>159.8</b>	6	29	<b>229.1</b>	4	4C
<b>97.4</b>	A	1B	<b>162.2</b>	6	12	<b>233.6</b>	4	37
<b>100.0</b>	9	D8	<b>167.9</b>	5	DD	<b>241.8</b>	4	12
<b>103.5</b>	9	83	<b>173.8</b>	5	AA	<b>250.3</b>	3	EF
<b>107.2</b>	9	2F	<b>179.9</b>	5	79	<b>254.1</b>	3	E0
<b>110.9</b>	8	E0	<b>183.5</b>	5	5D			

### 1.6.9 Rx Tone Program Tables : CTCSS

The following table lists the commonly used CTCSS tones together with the values for programming the "RX TONE PROGRAM" register (Hex address \$84).

N.B. The values for byte 1 and 2 below apply to tone address 0 only. These values will vary depending on the location they are programmed into.

Freq. (Hz)	Byte 1 (hex)	Byte 2 (hex)	Freq. (Hz)	Byte 1 (hex)	Byte 2 (hex)	Freq. (Hz)	Byte 1 (hex)	Byte 2 (hex)
<b>67.0</b>	3	D8	<b>114.8</b>	6	C0	<b>186.2</b>	A	C9
<b>69.3</b>	4	9	<b>118.8</b>	6	D1	<b>189.9</b>	B	8
<b>71.9</b>	4	1B	<b>123.0</b>	7	10	<b>192.8</b>	B	44
<b>74.4</b>	4	4E	<b>127.3</b>	7	50	<b>196.6</b>	B	83
<b>77.0</b>	4	83	<b>131.8</b>	7	C0	<b>199.5</b>	B	8A
<b>79.7</b>	4	94	<b>136.5</b>	8	2	<b>203.5</b>	B	C9
<b>82.5</b>	4	CB	<b>141.3</b>	8	44	<b>206.5</b>	C	6
<b>85.4</b>	5	2	<b>146.2</b>	8	86	<b>210.7</b>	C	46
<b>88.5</b>	5	14	<b>151.4</b>	8	C9	<b>218.1</b>	C	C3
<b>91.5</b>	5	4C	<b>156.7</b>	9	C	<b>225.7</b>	D	41
<b>94.8</b>	5	87	<b>159.8</b>	9	48	<b>229.1</b>	D	48
<b>97.4</b>	5	94	<b>162.2</b>	9	82	<b>233.6</b>	D	89
<b>100.0</b>	5	CB	<b>167.9</b>	9	C6	<b>241.8</b>	E	8
<b>103.5</b>	6	7	<b>173.8</b>	A	B	<b>250.3</b>	E	88
<b>107.2</b>	6	45	<b>179.9</b>	A	84	<b>254.1</b>	E	C7
<b>110.9</b>	6	82	<b>183.5</b>	A	C2			

**1.6.10 Tx Tone Program Table : Selcall**

The following two tables list commonly used Selcall tonesets together with the values for programming the 'SELCALL TX' register (\$8D).

EEA			CCIR		
Freq. (Hz)	Byte 1 (hex)	Byte 2 (hex)	Freq. (Hz)	Byte 1 (hex)	Byte 2 (hex)
1981	01	FD	1981	01	FD
1124	03	81	1124	03	81
1197	03	4A	1197	03	4A
1275	03	17	1275	03	17
1358	02	E6	1358	02	E6
1446	02	B9	1446	02	B9
1540	02	8F	1540	02	8F
1640	02	67	1640	02	67
1747	02	41	1747	02	41
1860	02	1E	1860	02	1E
1055	03	BB	2400	01	A4
930	04	3C	930	04	3C
2247	01	C1	2247	01	C1
991	03	F9	991	03	F9
2110	01	DE	2110	01	DE

ZVEI 1			ZVEI 2		
Freq. (Hz)	Byte 1 (hex)	Byte 2 (hex)	Freq. (Hz)	Byte 1 (hex)	Byte 2 (hex)
2400	01	A4	2400	01	A4
1060	03	B7	1060	03	B7
1160	03	65	1160	03	65
1270	03	1A	1270	03	1A
1400	02	D0	1400	02	D0
1530	02	93	1530	02	93
1670	02	5C	1670	02	5C
1830	02	27	1830	02	27
2000	01	F8	2000	01	F8
2200	01	CA	2200	01	CA
2800	01	68	885	04	73
810	04	DC	810	04	DC
970	04	0F	740	04	0F
885	04	73	680	05	CA
2600	01	84	970	04	0F



**1.6.11 Rx Tone Program Table : Selcall**

The following two tables list commonly used Selcall tonesets together with the values for programming the 'RX TONE PROGRAM' register (\$84) in each Tone Address location as shown.

Tone Address	EEA			CCIR		
	Freq. (Hz)	Byte 1 (hex)	Byte 2 (hex)	Freq. (Hz)	Byte 1 (hex)	Byte 2 (hex)
0	1981	A	A	1981	A	A
1	1124	15	C3	1124	15	C3
2	1197	26	D	1197	26	D
3	1275	36	85	1275	36	85
4	1358	46	D1	1358	46	D1
5	1446	57	4D	1446	57	4D
6	1540	67	CB	1540	67	CB
7	1640	78	4B	1640	78	4B
8	1747	88	CD	1747	88	CD
9	1860	99	84	1860	99	84
10	1055	A5	51	2400	AC	44
11	930	B4	C4	930	B4	C4
12	2247	CB	83	2247	CB	83
13	991	D5	A	991	D5	A
14	2110	EA	C5	2110	EA	C5

Tone Address	ZVEI 1			ZVEI 2		
	Freq. (Hz)	Byte 1 (hex)	Byte 2 (hex)	Freq. (Hz)	Byte 1 (hex)	Byte 2 (hex)
0	2400	C	44	2400	C	44
1	1060	15	53	1060	15	53
2	1160	25	D2	1160	25	D2
3	1270	36	83	1270	36	83
4	1400	47	E	1400	47	E
5	1530	57	C8	1530	57	C8
6	1670	68	86	1670	68	86
7	1830	79	49	1830	79	49
8	2000	8A	42	2000	8A	42
9	2200	9B	43	2200	9B	43
10	2800	AE	46	885	A4	86
11	810	B4	14	810	B4	14
12	970	C4	D8	740	C3	C8
13	885	D4	86	680	D3	80
14	2600	ED	45	970	E4	D8

**1.6.12 DCS Code Table**

The following table gives a list of DCS codes together with the corresponding values (in Hex) which should be programmed into the DCS BYTE registers for a 23-bit DCS sequence.

DCS Code	DCS Byte 3 (\$85)	DCS Byte 2 (\$86)	DCS Byte 1 (\$87)
023	76	38	13
025	6B	78	15
026	65	D8	16
031	51	F8	19
032	5F	58	1A
043	5B	68	23
047	0F	D8	27
051	7C	A8	29
054	6F	48	2C
065	5D	18	35
071	67	98	39
072	69	38	3A
073	2E	68	3B
074	74	78	3C
114	35	E8	4C
115	72	B8	4D
116	7C	18	4E
125	07	B8	55
131	3D	38	59
132	33	98	5A
134	2E	D8	5C
143	37	A8	63
152	1E	C8	6A
155	44	D8	6D
156	4A	78	6E
162	6B	C8	72
165	31	D8	75
172	05	F8	7A
174	18	B8	7C
205	6E	98	85
223	68	E8	93
226	7B	08	96
243	45	B8	A3
244	1F	A8	A4
245	58	F8	A5
251	62	78	A9
261	17	78	B1
263	5E	88	B3
265	43	C8	B5
271	79	48	B9
306	0C	F8	C6
311	38	D8	C9

DCS Code	DCS Byte 3 (\$85)	DCS Byte 2 (\$86)	DCS Byte 1 (\$87)
315	6C	68	CD
331	23	E8	D9
343	29	78	E3
346	3A	98	E6
351	0E	B8	E9
364	68	58	F4
365	2F	08	F5
371	15	88	F9
411	77	69	09
412	79	C9	0A
413	3E	99	0B
423	4B	99	13
431	6C	59	19
432	62	F9	1A
445	7B	89	25
464	27	E9	34
465	60	B9	35
466	6E	19	36
503	3C	69	43
506	2F	89	46
516	41	B9	4E
532	0E	39	5A
546	19	E9	66
565	0C	79	75
606	5D	99	86
612	67	19	8A
624	0F	59	94
627	01	F9	97
631	72	89	99
632	7C	29	9A
654	4C	39	AC
662	24	79	B2
664	39	39	B4
703	22	B9	C3
712	0B	D9	CA
723	39	89	D3
731	1E	49	D9
732	10	E9	DA
734	0D	A9	DC
743	14	D9	E3
754	20	F9	EC

## 1.7 Performance Specification

### 1.7.1 Electrical Performance

#### Absolute Maximum Ratings

Exceeding these maximum ratings can result in damage to the device.

	Min.	Max.	Units
Supply ( $V_{DD} - V_{SS}$ )	-0.3	7.0	V
Voltage on any pin to $V_{SS}$	-0.3	$V_{DD} + 0.3$	V
Current into or out of $V_{DD}$ and $V_{SS}$ pins	-30	+30	mA
Current into or out of any other pin	-20	+20	mA

<b>P4 Package</b>	Min.	Max.	Units
Total Allowable Power Dissipation at $T_{amb} = 25^{\circ}\text{C}$		1660	mW
... Derating		16.6	mW/ $^{\circ}\text{C}$
Storage Temperature	-55	+125	$^{\circ}\text{C}$
Operating Temperature	-40	+85	$^{\circ}\text{C}$

<b>D2 Package</b>	Min.	Max.	Units
Total Allowable Power Dissipation at $T_{amb} = 25^{\circ}\text{C}$		600	mW
... Derating		6.0	mW/ $^{\circ}\text{C}$
Storage Temperature	-55	+125	$^{\circ}\text{C}$
Operating Temperature	-40	+85	$^{\circ}\text{C}$

<b>D5 Package</b>	Min.	Max.	Units
Total Allowable Power Dissipation at $T_{amb} = 25^{\circ}\text{C}$		1490	mW
... Derating		14.9	mW/ $^{\circ}\text{C}$
Storage Temperature	-55	+125	$^{\circ}\text{C}$
Operating Temperature	-40	+85	$^{\circ}\text{C}$

#### Operating Limits

Correct operation of the device outside these limits is not implied.

	Notes	Min.	Max.	Units
Supply ( $V_{DD} - V_{SS}$ )		3.0	5.5	V
Operating Temperature		-40	+85	$^{\circ}\text{C}$
Xtal Frequency		4.0315968	4.0324032	MHz

**Operating Characteristics**

For the following conditions unless otherwise specified:

Xtal Frequency = 4.032MHz

Audio Level 0dB ref = 308mVrms at 1kHz

 $V_{DD} = 3.3V$  to  $5.0V$ ,  $T_{amb} = -40^{\circ}C$  to  $+85^{\circ}C$ .

Composite Signal = 308mVrms at 1kHz + 75mVrms Noise + 31mVrms Sub-Audio Signal

Noise Bandwidth = 5kHz Band Limited Gaussian

	Notes	Min.	Typ.	Max.	Units
<b>DC Parameters</b>					
<b>At <math>V_{DD} = 3.3V</math></b>					
$I_{DD}$ (all powersaved)	2	-	0.5	1.0	mA
$I_{DD}$ (FAST DETECT Enabled)	2	-	0.7	2.5	mA
$I_{DD}$ (Rx Operating - DCS, FAST DETECT and CTCSS or Selcall)	2	-	1.0	4.5	mA
$I_{DD}$ (Tx Operating - DCS or Selcall or SUB AUDIO)	2	-	0.7	3.0	mA
$I_{DD}$ (Tx Operating - DCS and Selcall)	2	-	0.8	4.0	mA
<b>At <math>V_{DD} = 5V</math></b>					
$I_{DD}$ (all powersaved)	2	-	1.0	1.5	mA
$I_{DD}$ (FAST DETECT Enabled)	2	-	1.1	4.5	mA
$I_{DD}$ (Rx Operating - DCS, FAST DETECT and CTCSS or Selcall)	2	-	1.7	7.5	mA
$I_{DD}$ (Tx Operating - DCS or Selcall or SUB AUDIO)	2	-	1.2	6.0	mA
$I_{DD}$ (Tx Operating - DCS and Selcall)	2	-	1.3	6.5	mA
<b>"C-BUS" Interface</b>					
Input Logic "1"		70%	-	-	$V_{DD}$
Input Logic "0"		-	-	30%	$V_{DD}$
Input Leakage Current (Logic "1" or "0")		-1.0	-	1.0	$\mu A$
Input Capacitance		-	-	7.5	pF
Output Logic "1" ( $I_{OH} = 120\mu A$ )		90%	-	-	$V_{DD}$
Output Logic "0" ( $I_{OL} = 360\mu A$ )		-	-	10%	$V_{DD}$
"Off" State Leakage Current ( $V_{out} = V_{DD}$ )	6	-	-	10	$\mu A$
<b>AC Parameters</b>					
<b>TONE Decoder</b>					
Sensitivity (Pure Tone)	5	-	-26.0	-	dB
CTCSS					
Response Time (Composite Signal)		-	140	-	ms
De-response Time (Composite Signal)		-	145	-	ms
Frequency Range SELCALL		60	-	253	Hz
Response Time (Good Signal)		-	14	-	ms
De-response Time (Good Signal)		-	22	-	ms
Frequency Range		625	-	3000	Hz
<b>DCS Decoder</b>					
Bit-Rate Sync Time		-	2	-	edges
Sensitivity	1	58	-	116	mVp-p

	Notes	Min.	Typ.	Max.	Units
<b>CTCSS Detector - Fast Detect</b>					
Sensitivity (Pure CTCSS Tone)	5	-	-26.0	-	dB
Response Time (Composite Signal)		-	56.0	-	ms
Frequency Range		60.0	-	253	Hz
<b>CTCSS Detector - Fast Predictive</b>					
Sensitivity (Pure CTCSS Tone)	5	-	-26.0	-	dB
Response Time (Composite Signal)	7	-	37.0	-	ms
Frequency Range		60.0	-	253	Hz
Decode Bandwidth		-	40.0	-	Hz
<b>CTCSS Encoder</b>					
Frequency Range		60.0	-	253	Hz
Tone Frequency Resolution		-	-	0.2	%
Tone Amplitude Tolerance	1	-1.0	-	+1.0	dB
Total Harmonic Distortion	9	-	2.0	-	%
<b>SELCALL Encoder</b>					
Frequency Range		208	-	3000	Hz
Tone Frequency Resolution		-	-	0.2	%
Tone Amplitude Tolerance	1	-1.0	-	+1.0	dB
Total Harmonic Distortion	9	-	2.0	-	%
<b>DCS Encoder</b>					
Bit Rate		-	134.4	-	bits/s
Amplitude Tolerance	1	-1.0	-	+1.0	dB
Amplitude	1	-	871	-	mVp-p
<b>Audio Band-Pass Filter</b>					
Passband	8	300	-	3000	Hz
Passband Gain (at 1.0kHz)	8	-	0	-	dB
Passband Ripple (w.r.t. gain at 1.0kHz)	8	-2	-	+0.5	dB
Stopband Attenuation	8	33.0	-	-	dB
Residual Hum and Noise		-	-50.0	-	dBp
Alias Frequency		-	63	-	kHz
<b>Output Impedances</b>					
TX AUDIO OUT, TX SUB AUDIO ) Enabled	10	-	2.0	-	k $\Omega$
OUT and RX AUDIO OUT ) Disabled		-	500	-	k $\Omega$
<b>Rx Amp and Summing Amp</b>					
Open Loop Gain (I/P = 1mV at 100Hz)		-	70.0	-	dB
Unity Gain Bandwidth		-	5.0	-	MHz
Input Impedance (at 100Hz)		10	-	-	M $\Omega$
Output Impedance (Open Loop)		-	6.0	-	k $\Omega$

	Notes	Min.	Typ.	Max.	Units
<b>Transmitter Modulator Drives:</b>					
<b>Mod.1 Attenuator</b>					
Attenuation (at 0dB)		-0.3	0	0.2	dB
Cumulative Attenuation Error (wrt attenuation at 0dB)		-1.0	-	1.0	dB
Output Impedance	3	-	600	-	$\Omega$
Input Impedance (at 100Hz)		-	15.0	-	k $\Omega$
<b>Mod.2 Attenuator</b>					
Attenuation (at 0dB)		-0.3	0	0.2	dB
Cumulative Attenuation Error (wrt attenuation at 0dB)		-0.6	-	0.6	dB
Output Impedance	3	-	600	-	$\Omega$
<b>General Purpose Timer</b>					
Timing Period Range		1	-	255	ms
Count Interval		-	1	-	ms
<b>Xtal/Clock Input</b>					
Pulse Width ('High' or 'Low')	4	40.0	-	-	ns
Input Impedance (at 100Hz)		10.0	-	-	M $\Omega$
Gain (I/P = 1mVrms at 100Hz)		20.0	-	-	dB
<b>DAC</b>					
Range	1	312.5	-	2500	mV
Step Size	1	-	312.5	-	mV
Step Accuracy	1	-30.0	-	+30.0	mV
Input Impedance (COMPIN)		-	10	-	M $\Omega$
Output Impedance (COMPOUT)		-	1	-	k $\Omega$

- Notes:**
1. At  $V_{DD} = 5.0V$  only. Signal levels or currents are proportional to  $V_{DD}$ .
  2. At  $T_{amb} = 25^{\circ}C$ , not including any current drawn from the device pins by external circuitry.
  3. Small signal impedance, at  $V_{DD} = 5.0V$  and  $T_{amb} = 25^{\circ}C$ .
  4. Timing for an external input to the XTAL/CLOCK pin.
  5. With input gain components set as recommended in Figure 2.
  6. IRQN pin.
  7. From one tone to another tone.
  8. See filter response (Figure 3).
  9. Measured at MOD1 or MOD2 output.
  10. SUBAUDIO, SELCALL and DCS.

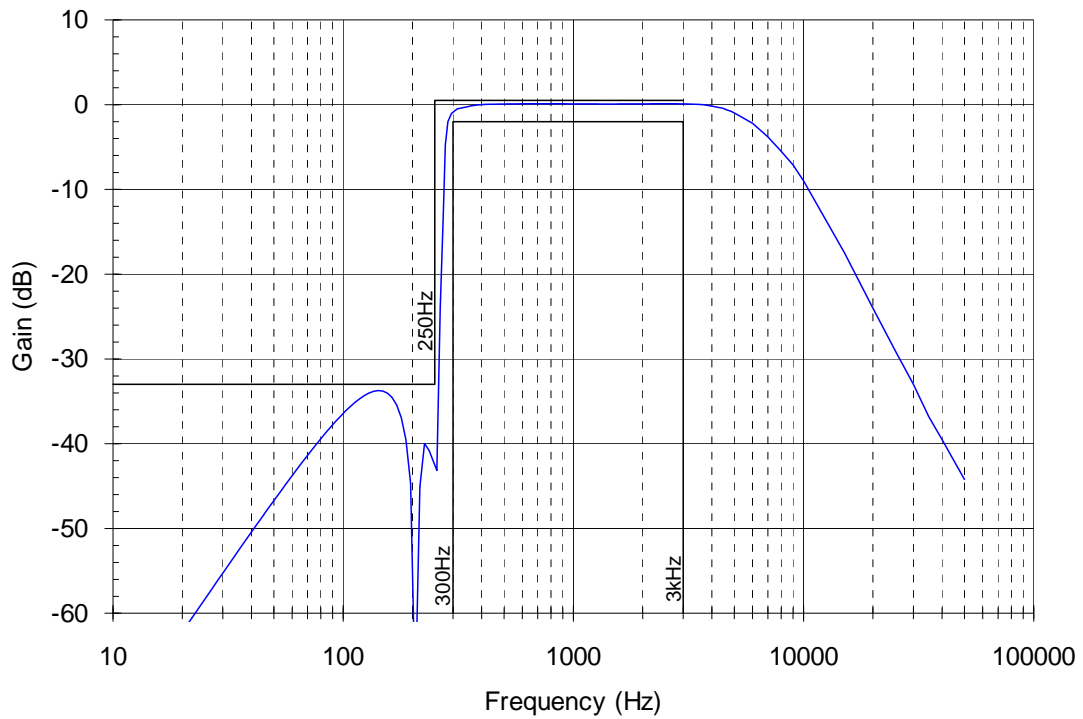

Figure 3 Typical Audio Band-Pass Filter Frequency Response

Timing Diagrams

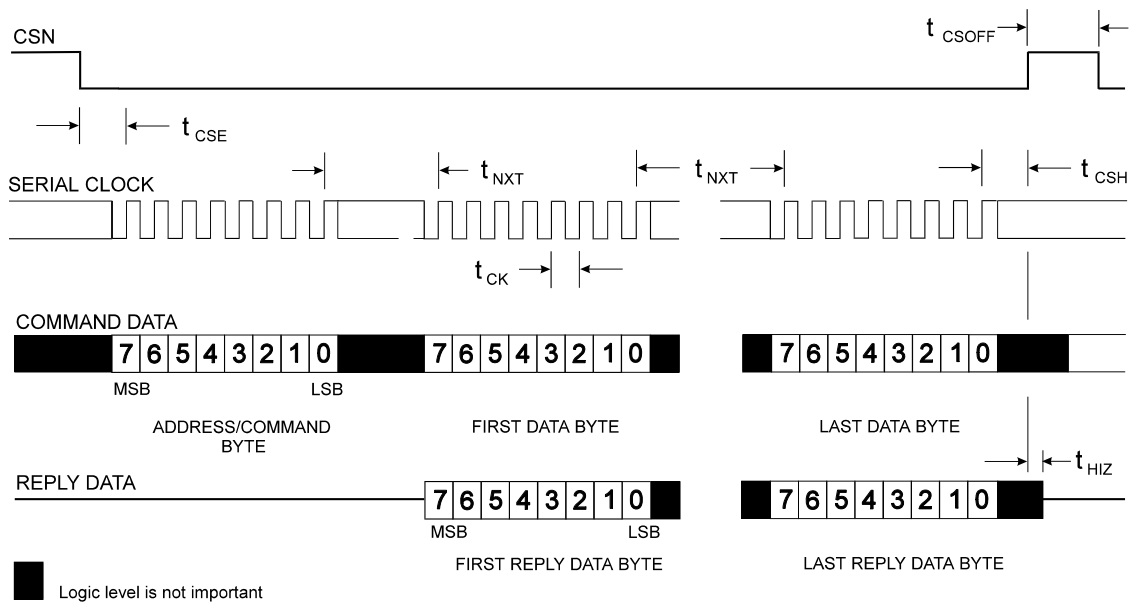

Figure 4 "C-BUS" Timing

For the following conditions unless otherwise specified:

Xtal Frequency = 4.032MHz,  $V_{DD}$  = 3.3V to 5.0V,  $T_{amb}$  = -40°C to +85°C.

	<b>Parameter</b>	<b>Notes</b>	<b>Min.</b>	<b>Typ.</b>	<b>Max.</b>	<b>Units</b>
$t_{CSE}$	"CS-Enable to Clock-High"		2.0		-	$\mu s$
$t_{CSH}$	Last "Clock-High to CS-High"		4.0		-	$\mu s$
$t_{HIZ}$	"CS-High to Reply Output 3-state"		-		2.0	$\mu s$
$t_{CSOFF}$	"CS-High" Time between transactions		2.0		-	$\mu s$
$t_{NXT}$	"Inter-Byte" Time		4.0		-	$\mu s$
$t_{CK}$	"Clock-Cycle" time		2.0		-	$\mu s$

- Notes:**
1. Depending on the command, 1 or 2 bytes of COMMAND DATA are transmitted to the peripheral MSB (Bit 7) first, LSB (Bit 0) last. REPLY DATA is read from the peripheral MSB (Bit 7) first, LSB (Bit 0) last.
  2. Data is clocked into and out of the peripheral on the rising SERIAL CLOCK edge.
  3. Loaded commands are acted upon at the end of each command.
  4. To allow for differing  $\mu$ Controller serial interface formats "C-BUS" compatible ICs are able to work with either polarity SERIAL CLOCK pulses.



1.7.2 Packaging

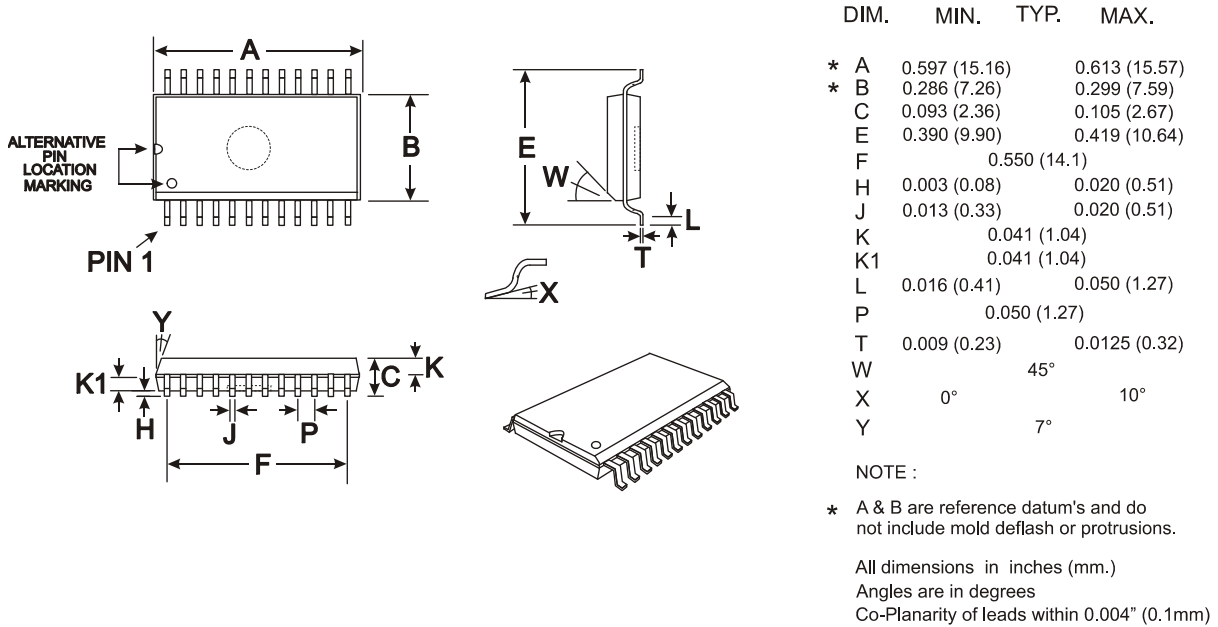

Figure 5 Mechanical Outline: Order as part no. FX828D2

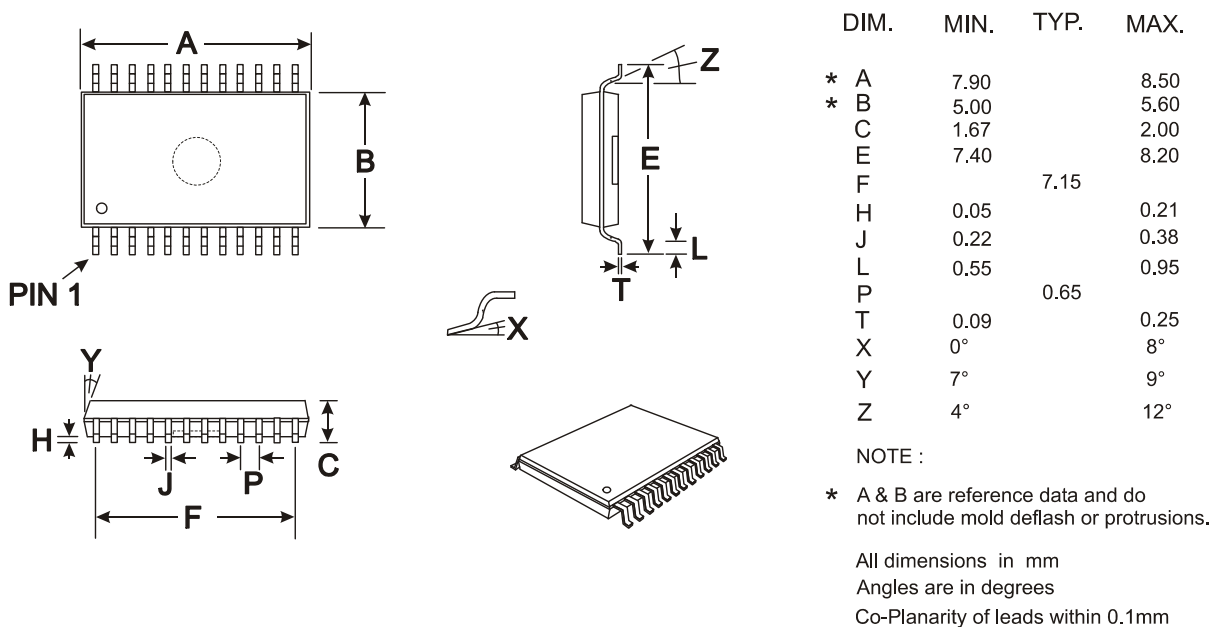
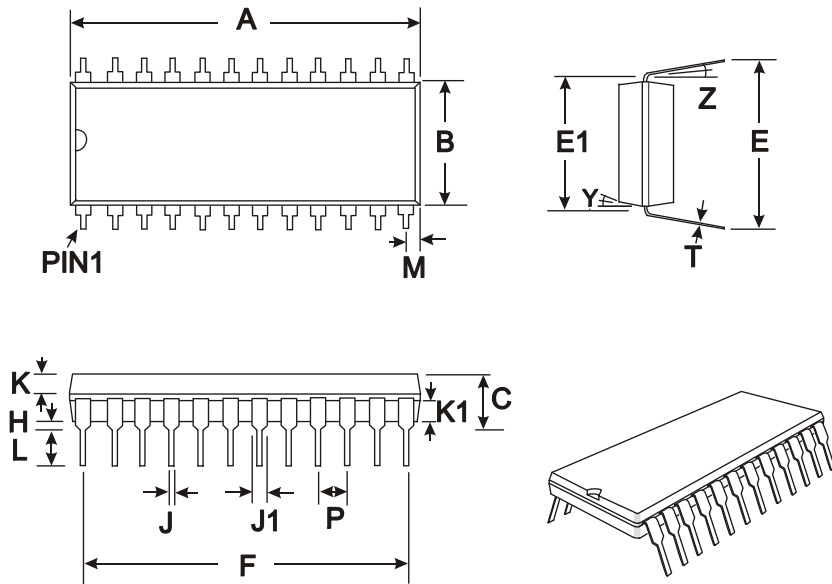

Figure 6 Mechanical Outline: Order as part no. FX828D5

1.7.2 Packaging (continued)



DIM.	MIN.	TYP.	MAX.
* A	1.200 (30.48)		1.270 (32.26)
* B	0.500 (12.70)		0.555 (14.10)
C	0.142(3.61)		0.220 (5.59)
E	0.600 (15.24)		0.670 (17.02)
E1	0.590 (14.99)		0.625 (15.88)
F		1.10 (27.94)	
H	0.015 (0.38)		0.045 (1.14)
J	0.015 (0.38)		0.023 (0.58)
J1	0.040 (1.02)		0.065 (1.65)
K	0.066 (1.68)		0.074 (1.88)
K1	0.060 (1.52)		0.074 (1.88)
L	0.121 (3.07)		0.160 (4.06)
M		0.180 (4.58)	
P		0.100 (2.54)	
T	0.008 (0.20)		0.015 (0.38)
Y		7°	
Z		4°	

NOTE :

\* A & B are reference datum's and do not include mold flash or protrusions.

All dimensions in inches (mm.)  
Angles are in degrees

Figure 7 Mechanical Outline: Order as part no. FX828P4

Handling precautions: This product includes input protection, however, precautions should be taken to prevent device damage from electro-static discharge. CML does not assume any responsibility for the use of any circuitry described. No IPR or circuit patent licences are implied. CML reserves the right at any time without notice to change the said circuitry and this product specification. CML has a policy of testing every product shipped using calibrated test equipment to ensure compliance with this product specification. Specific testing of all circuit parameters is not necessarily performed.

 <b>CML Microcircuits (UK) Ltd</b> <small>COMMUNICATION SEMICONDUCTORS</small>	 <b>CML Microcircuits (USA) Inc.</b> <small>COMMUNICATION SEMICONDUCTORS</small>	 <b>CML Microcircuits (Singapore) Pte Ltd</b> <small>COMMUNICATION SEMICONDUCTORS</small>
<b>Tel:</b> +44 (0)1621 875500 <b>Fax:</b> +44 (0)1621 875600 <b>Sales:</b> sales@cmlmicro.com  <b>Tech Support:</b> techsupport@cmlmicro.com	<b>Tel:</b> +1 336 744 5050 800 638 5577 <b>Fax:</b> +1 336 744 5054 <b>Sales:</b> us.sales@cmlmicro.com <b>Tech Support:</b> us.techsupport@cmlmicro.com	<b>Tel:</b> +65 67450426 <b>Fax:</b> +65 67452917 <b>Sales:</b> sg.sales@cmlmicro.com <b>Tech Support:</b> sg.techsupport@cmlmicro.com
- <a href="http://www.cmlmicro.com">www.cmlmicro.com</a> -		