

The RF MOSFET Line
RF Power
Field Effect Transistors
N-Channel Enhancement-Mode Lateral
MOSFETs

MRF183R1
MRF183LSR1

1.0 GHz, 45 W, 28 V
LATERAL N-CHANNEL
BROADBAND
RF POWER MOSFETs

Designed for broadband commercial and industrial applications with frequencies to 1.0 GHz. The high gain and broadband performance of these devices make them ideal for large-signal, common source amplifier applications in 28 volt base station equipment.

- Guaranteed Performance at 945 MHz, 28 Volts
Output Power — 45 Watts PEP
Power Gain — 11.5 dB
Efficiency — 33%
IMD — - 28 dBc
- Excellent Thermal Stability
- Characterized with Series Equivalent Large-Signal Impedance Parameters
- S-Parameter Characterization at High Bias Levels
- 100% Tested for Load Mismatch Stress at all Phase Angles with 5:1 VSWR @ 28 Vdc, 945 MHz, 45 Watts CW
- In Tape and Reel. R1 Suffix = 500 Units per 32 mm, 13 inch Reel.

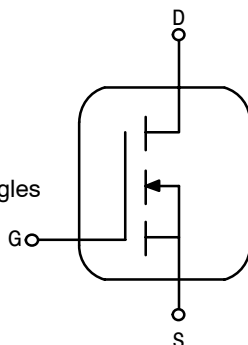

CASE 360B-05, STYLE 1
NI-360
MRF183R1

CASE 360C-05, STYLE 1
NI-360S
MRF183LSR1

MAXIMUM RATINGS

Rating	Symbol	Value	Unit
Drain-Source Voltage	V_{DSS}	65	Vdc
Drain-Gate Voltage (RGS = 1 Meg Ohm)	V_{DGR}	65	Vdc
Gate-Source Voltage	V_{GS}	± 20	Vdc
Drain Current - Continuous	I_D	5	Adc
Total Device Dissipation @ $T_C = 70^\circ\text{C}$ Derate above 70°C	P_D	86 0.67	W W/ $^\circ\text{C}$
Storage Temperature Range	T_{stg}	- 65 to +200	$^\circ\text{C}$
Operating Junction Temperature	T_J	200	$^\circ\text{C}$

THERMAL CHARACTERISTICS

Characteristic	Symbol	Max	Unit
Thermal Resistance, Junction to Case	$R_{\theta JC}$	1.5	$^\circ\text{C}/\text{W}$

NOTE - **CAUTION** - MOS devices are susceptible to damage from electrostatic charge. Reasonable precautions in handling and packaging MOS devices should be observed.

ELECTRICAL CHARACTERISTICS ($T_C = 25^\circ\text{C}$ unless otherwise noted)

Characteristic	Symbol	Min	Typ	Max	Unit
----------------	--------	-----	-----	-----	------

OFF CHARACTERISTICS

Drain-Source Breakdown Voltage ($V_{GS} = 0 \text{ Vdc}$, $I_D = 50 \mu\text{Adc}$)	BV_{DSS}	65	-	-	Vdc
Zero Gate Voltage Drain Current ($V_{DS} = 28 \text{ Vdc}$, $V_{GS} = 0 \text{ Vdc}$)	I_{DSS}	-	-	1	μAdc
Gate-Source Leakage Current ($V_{GS} = 20 \text{ Vdc}$, $V_{DS} = 0 \text{ Vdc}$)	I_{GSS}	-	-	1	μAdc

ON CHARACTERISTICS

Gate Quiescent Voltage ($V_{DS} = 28 \text{ Vdc}$, $I_D = 250 \text{ mAdc}$)	$V_{GS(Q)}$	3	-	5	Vdc
Drain-Source On-Voltage ($V_{GS} = 10 \text{ V}$, $I_D = 3 \text{ A}$)	$V_{DS(on)}$	-	0.7	-	Vdc
Forward Transconductance ($V_{DS} = 10 \text{ Vdc}$, $I_D = 5 \text{ Adc}$)	g_{fs}	-	2	-	S

DYNAMIC CHARACTERISTICS

Input Capacitance ($V_{DS} = 28 \text{ V}$, $V_{GS} = 0$, $f = 1 \text{ MHz}$)	C_{iss}	-	82	-	pF
Output Capacitance ($V_{DS} = 28 \text{ V}$, $V_{GS} = 0$, $f = 1 \text{ MHz}$)	C_{oss}	-	38	-	pF
Reverse Transfer Capacitance ($V_{DS} = 28 \text{ V}$, $V_{GS} = 0$, $f = 1 \text{ MHz}$)	C_{rss}	-	4.5	-	pF

FUNCTIONAL TESTS (In Motorola Test Fixture, 50 ohm system)

($V_{DD} = 28 \text{ Vdc}$, $P_{out} = 45 \text{ Watts PEP}$, $f_1 = 945.0$, $f_2 = 945.1 \text{ MHz}$, $I_{DQ} = 250 \text{ mA}$)

Two-Tone Common Source Amplifier Power Gain	G_{ps}	11.5	13.5	-	dB
Two-Tone Drain Efficiency	η	33	38	-	%
3rd Order Intermodulation Distortion	IMD	-	-32	-28	dBc
Input Return Loss	IRL	9	14	-	dB

($V_{DD} = 28 \text{ Vdc}$, $P_{out} = 45 \text{ Watts PEP}$, $f_1 = 930.0$, $f_2 = 930.1 \text{ MHz}$, and $f_1 = 960.0$, $f_2 = 960.1 \text{ MHz}$, $I_{DQ} = 250 \text{ mA}$)

Two-Tone Common Source Amplifier Power Gain	G_{ps}	-	13	-	dB
Two-Tone Drain Efficiency	η	-	35	-	%
3rd Order Intermodulation Distortion	IMD	-	-32	-	dBc
Input Return Loss	IRL	-	12	-	dB
Output Mismatch Stress ($V_{DD} = 28 \text{ Vdc}$, $P_{out} = 45 \text{ Watts CW}$, $I_{DQ} = 250 \text{ mA}$, $f = 945 \text{ MHz}$, VSWR 5:1 at All Phase Angles)	Ψ	No Degradation in Output Power Before and After Test			

ARCHIVED 2005

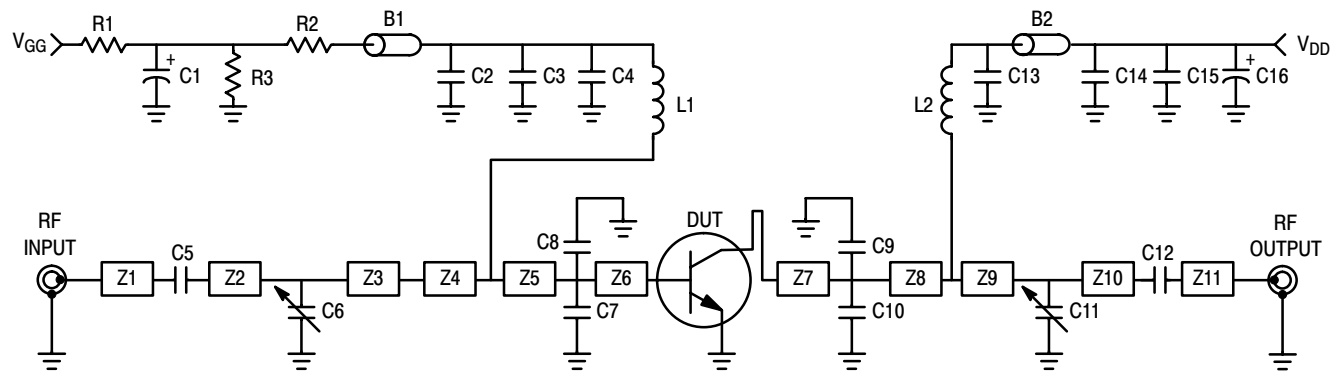

B1	Short Ferrite Bead	R3	4.7 MΩ, 1/4 W Carbon
B2	Long Ferrite Bead	Z1	T-Line, 0.200" x 0.080"
C1	10 μF, 50 V Electrolytic Capacitor	Z2	T-Line, 0.570" x 0.120"
C2, C14	0.1 μF Chip Capacitor	Z3	T-Line, 0.610" x 0.320"
C3	1000 pF Chip Capacitor	Z4	T-Line, 0.160" x 0.320" x 0.620"
C4, C13	47 pF Chip Capacitor	Z5	Tapered Line
C5, C12	47 pF Chip Capacitor	Z6	T-Line, 0.650" x 0.620"
C6, C11	0.8-8.0 pF Trim Capacitor	Z7	T-Line, 0.020" x 0.620"
C7, C8	10 pF Chip Capacitor	Z8	T-Line, 0.270" x 0.320"
C9, C10	10 pF Chip Capacitor	Z9	T-Line, 0.130" x 0.320"
C15	100 pF Chip Capacitor	Z10	T-Line, 0.370" x 0.080"
C16	250 μF, 50 V Electrolytic Capacitor	Z11	T-Line, 1.050" x 0.080"
L1, L2	5 Turns, 24 AWG, ID 0.059"	Board	T-Line, 0.290" x 0.080"
R1	120 Ω, 1/4 W Carbon		0.030" Glass Teflon, ε _r = 2.55
R2	18 kΩ, 1/4 W Carbon		ARLON-GX-0300-55-22

Figure 1. MRF183LSR1 Two Tone Test Circuit Schematic

TYPICAL CHARACTERISTICS

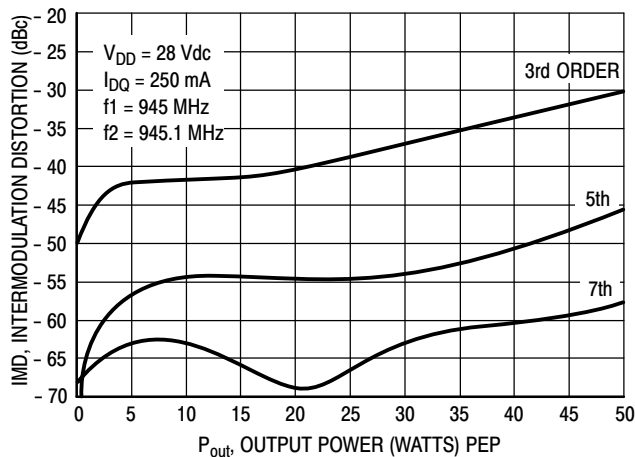

Figure 2. Intermodulation Distortion Products versus Output Power

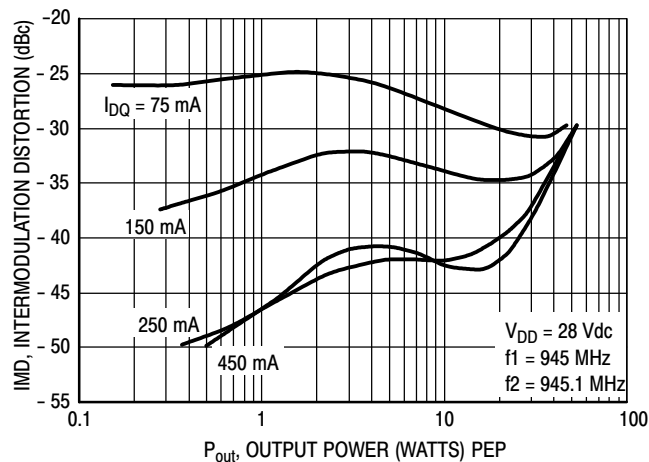

Figure 3. Intermodulation Distortion versus Output Power

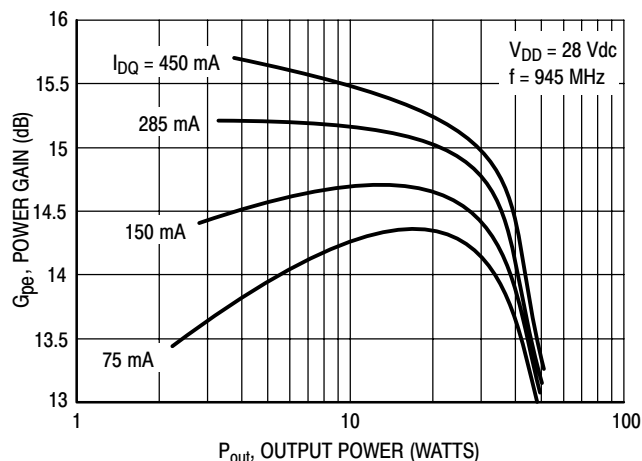

Figure 4. Power Gain versus Output Power

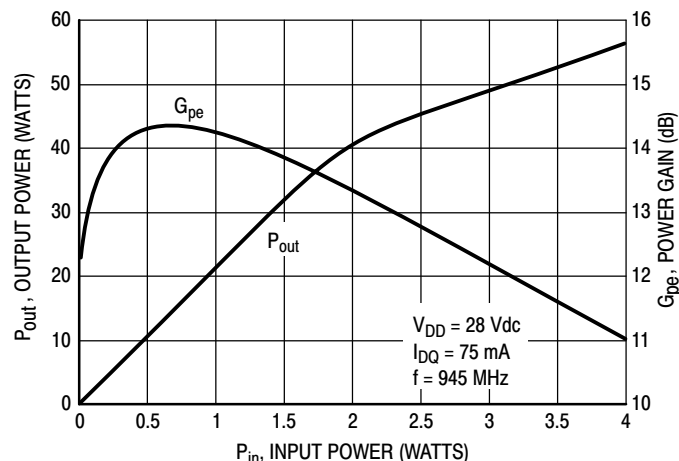

Figure 5. Output Power versus Input Power

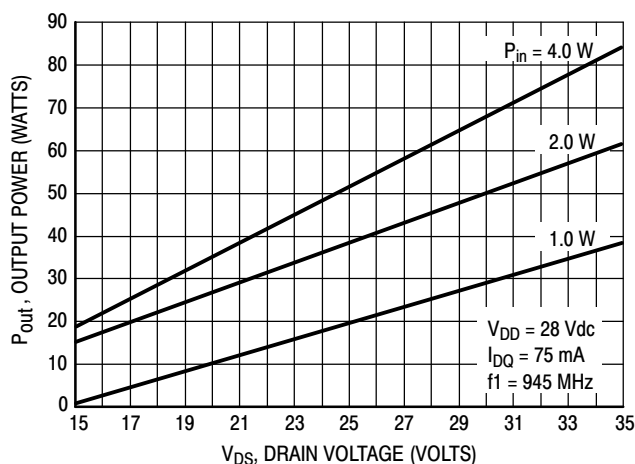

Figure 6. Output Power versus Drain Bias Supply Voltage

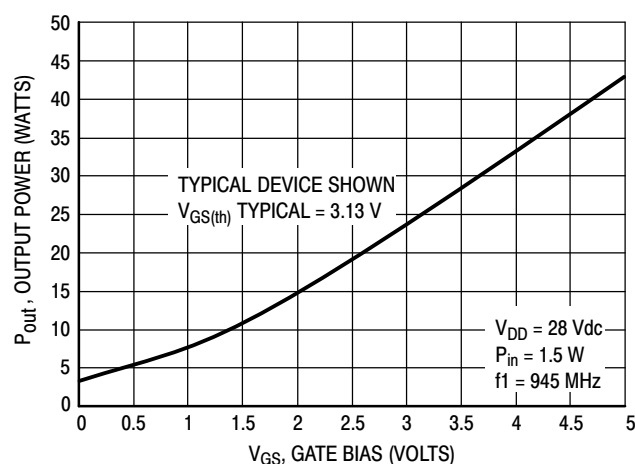

Figure 7. Output Power versus Gate Bias Supply Voltage

ARCHIVED 2005

TYPICAL CHARACTERISTICS

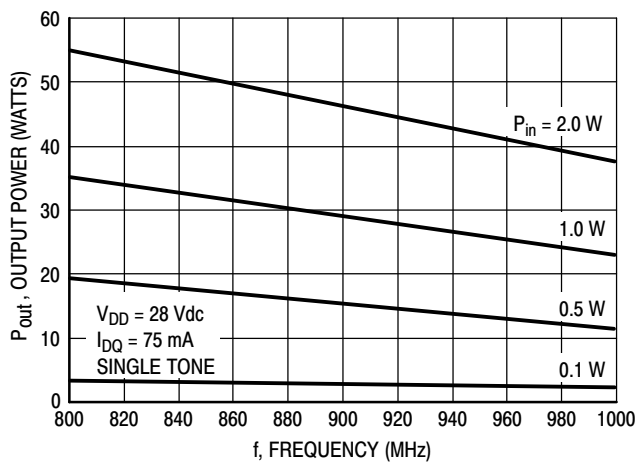

Figure 8. Output Power versus Frequency

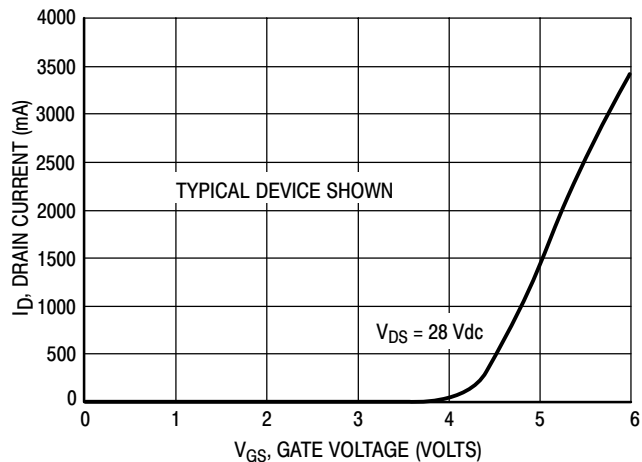

Figure 9. Drain Current versus Gate Voltage

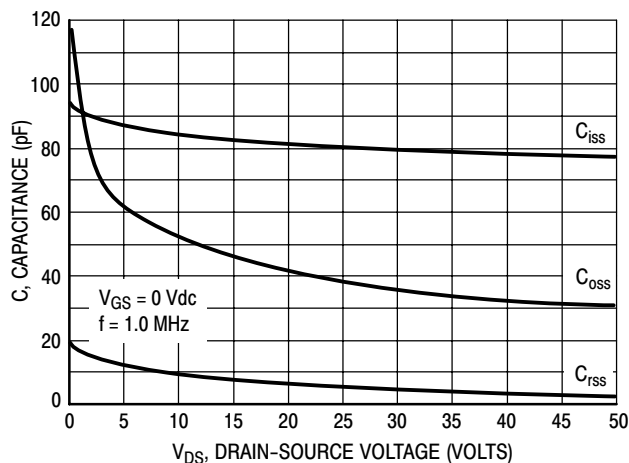

Figure 10. Capacitance versus Voltage

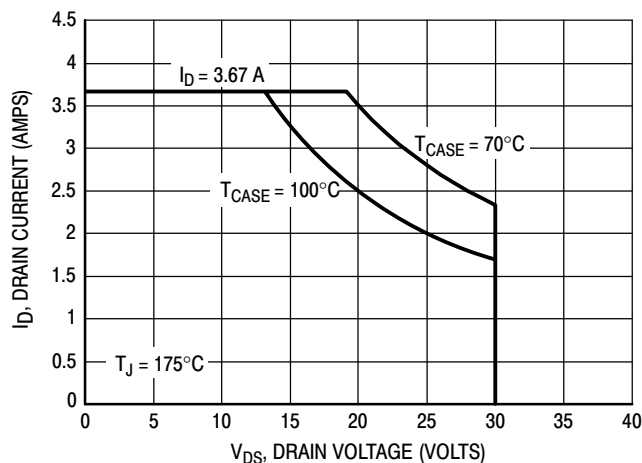

Figure 11. Class A Safe Operating Region

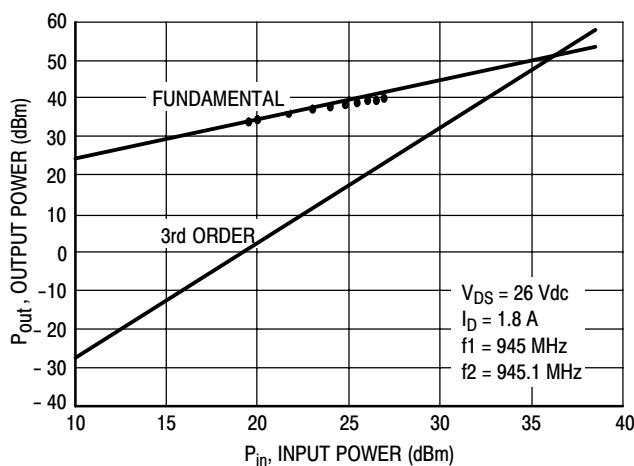

Figure 12. Class A Third Order Intercept Point

ARCHIVED 2005

TYPICAL CHARACTERISTICS

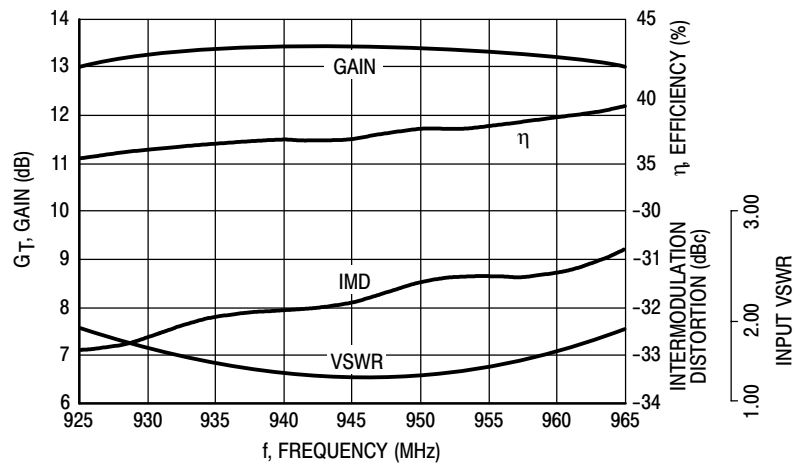

Figure 13. Broadband Power Performance of MRF183LSR1

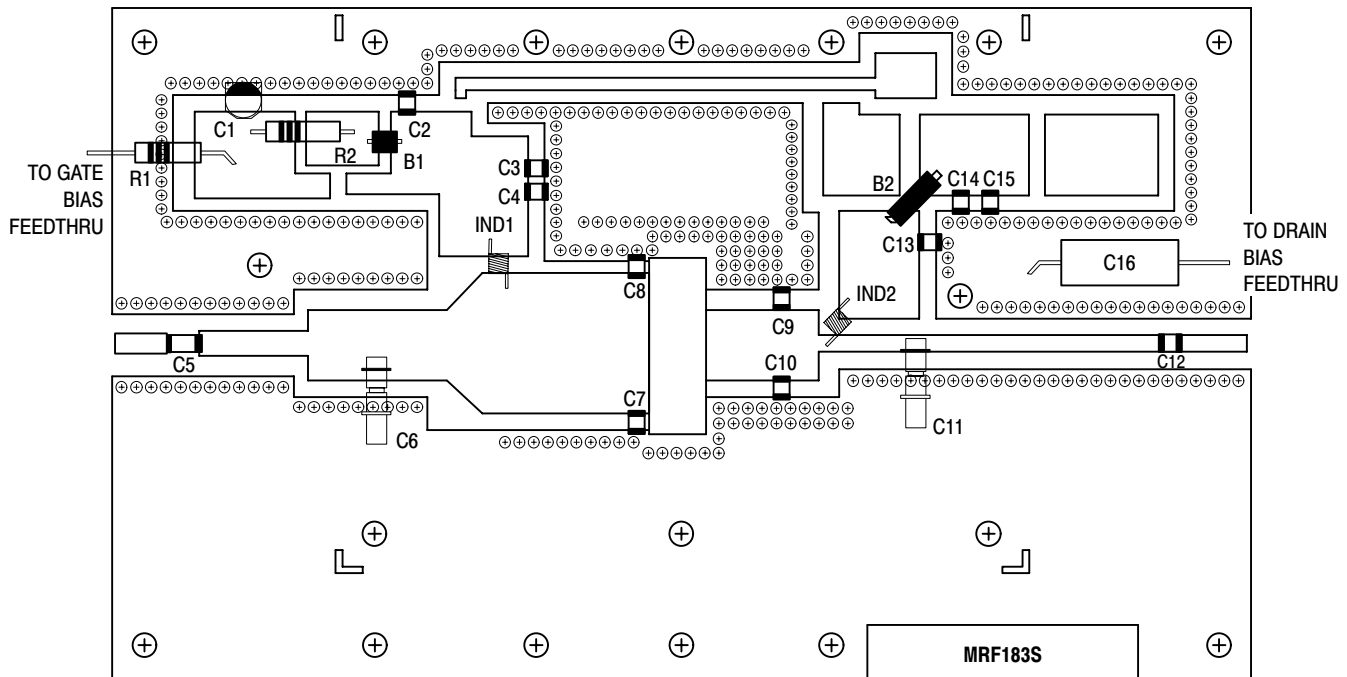
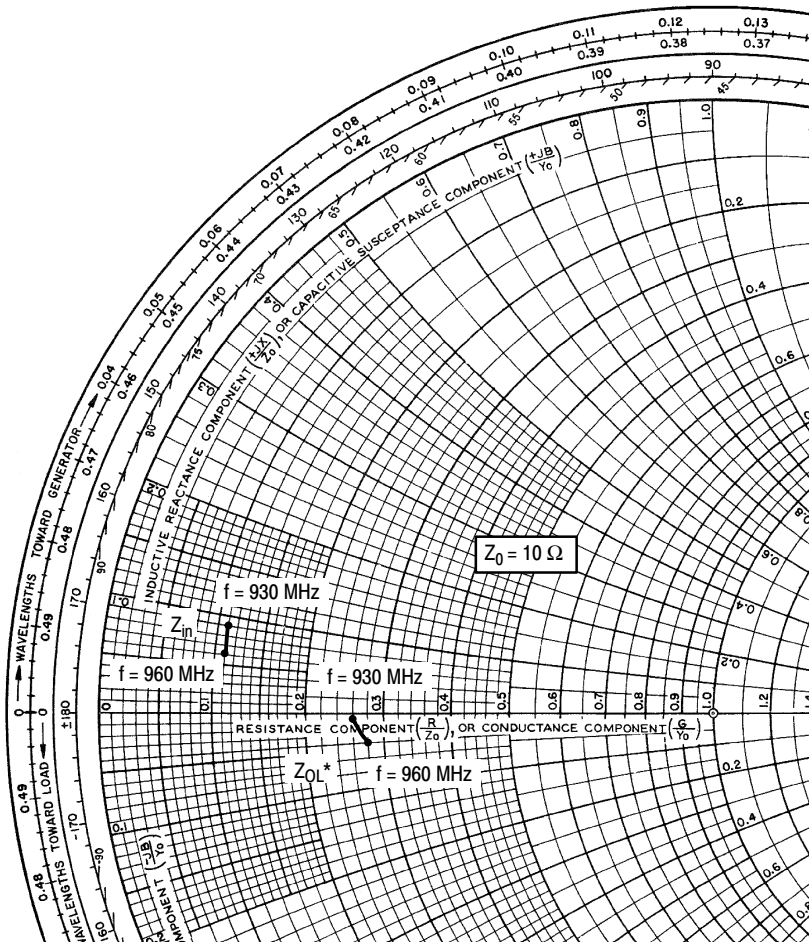

Figure 14. MRF183LSR1 Two Tone Test Circuit Component Parts Layout

ARCHIVED 2005



$V_{DD} = 28\text{ V}$, $I_{DQ} = 250\text{ mA}$, $P_{out} = 45\text{ W PEP}$

f MHz	Z_{in} Ohms	Z_{OL}^* Ohms
930	$1.10 + j0.93$	$2.60 - j0.13$
945	$1.10 + j0.78$	$2.70 - j0.28$
960	$1.10 + j0.60$	$2.80 - j0.42$

Z_{in} = Conjugate of source impedance.

Z_{OL}^* = Conjugate of the load impedance at a given output power, voltage, and current conditions.

Note: Z_{OL}^* was chosen based on tradeoffs between gain, output power, drain efficiency and intermodulation distortion.

Figure 15. Series Equivalent Input and Output Impedance

Table 1. Typical Common Source S-Parameters ($V_{DS} = 13.5\text{ V}$)

$I_D = 1.5\text{ A}$

f MHz	S ₁₁		S ₂₁		S ₁₂		S ₂₂	
	S ₁₁	∠φ	S ₂₁	∠φ	S ₁₂	∠φ	S ₂₂	∠φ
20	0.954	-157	29.58	100	0.017	11	0.778	-161
30	0.941	-164	19.73	96	0.017	8	0.796	-168
40	0.922	-168	14.84	93	0.017	4	0.804	-170
50	0.907	-171	11.94	91	0.017	3	0.808	-172
60	0.903	-172	9.75	89	0.017	2	0.812	-173
70	0.899	-173	8.34	88	0.017	0	0.814	-174
80	0.898	-174	7.29	86	0.017	-1	0.816	-175
90	0.896	-175	6.49	85	0.017	-2	0.816	-175
100	0.897	-175	5.83	84	0.017	-2	0.817	-175
150	0.895	-177	3.82	79	0.017	-6	0.822	-176
200	0.898	-178	2.84	74	0.016	-9	0.828	-176
250	0.902	-178	2.24	70	0.016	-11	0.835	-176
300	0.908	-179	1.84	66	0.015	-14	0.842	-176
350	0.905	-179	1.55	62	0.015	-16	0.850	-176
400	0.913	-180	1.32	58	0.014	-18	0.861	-176
450	0.920	180	1.15	54	0.014	-18	0.865	-176
500	0.924	179	1.01	51	0.013	-20	0.874	-177
550	0.922	179	0.89	47	0.013	-21	0.881	-177
600	0.931	178	0.80	44	0.012	-21	0.889	-177
650	0.935	178	0.72	41	0.011	-20	0.895	-177
700	0.935	177	0.64	38	0.011	-17	0.901	-178
750	0.937	177	0.59	37	0.012	-18	0.905	-178
800	0.940	176	0.54	33	0.012	-20	0.913	-178
850	0.943	176	0.50	30	0.012	-29	0.919	-179
900	0.945	175	0.46	28	0.010	-33	0.924	-179
950	0.947	174	0.43	26	0.009	-34	0.930	-180
1000	0.947	174	0.40	24	0.008	-29	0.935	180
1050	0.947	173	0.37	21	0.007	-24	0.939	179
1100	0.952	172	0.35	19	0.007	-19	0.944	179
1150	0.949	172	0.32	17	0.007	-17	0.948	178
1200	0.946	171	0.30	14	0.006	-16	0.948	177
1250	0.954	170	0.28	12	0.006	-13	0.953	177
1300	0.952	170	0.27	9	0.006	-12	0.950	176
1350	0.949	169	0.26	9	0.006	-10	0.951	176
1400	0.948	168	0.23	8	0.005	-7	0.953	175
1450	0.948	168	0.22	6	0.004	4	0.948	174
1500	0.940	167	0.21	4	0.004	19	0.944	174

ARCHIVED 2005

Table 2. Typical Common Source S-Parameters ($V_{DS} = 28\text{ V}$)

$I_D = 1.5\text{ A}$

f MHz	S ₁₁		S ₂₁		S ₁₂		S ₂₂	
	S ₁₁	∠φ	S ₂₁	∠φ	S ₁₂	∠φ	S ₂₂	∠φ
20	0.968	-132	45.79	113	0.014	24	0.579	-145
30	0.953	-145	31.75	106	0.015	17	0.623	-157
40	0.921	-154	24.33	99	0.015	12	0.648	-161
50	0.904	-159	19.68	95	0.015	7	0.661	-164
60	0.898	-163	16.11	92	0.015	5	0.670	-166
70	0.890	-165	13.79	90	0.015	2	0.677	-167
80	0.886	-167	12.06	87	0.015	1	0.681	-168
90	0.886	-168	10.71	86	0.015	-1	0.684	-169
100	0.887	-169	9.61	84	0.015	-3	0.688	-169
150	0.886	-172	6.26	76	0.015	-9	0.706	-170
200	0.890	-174	4.59	69	0.014	-13	0.724	-170
250	0.898	-175	3.57	64	0.014	-17	0.744	-169
300	0.906	-176	2.88	59	0.013	-19	0.764	-169
350	0.908	-177	2.37	54	0.012	-23	0.785	-169
400	0.915	-178	2.00	49	0.011	-24	0.807	-170
450	0.924	-178	1.71	45	0.010	-25	0.821	-170
500	0.930	-179	1.48	41	0.010	-26	0.838	-171
550	0.928	-180	1.28	37	0.009	-26	0.851	-171
600	0.937	180	1.13	33	0.008	-25	0.865	-172
650	0.944	179	1.00	30	0.007	-22	0.878	-172
700	0.943	178	0.88	27	0.008	-14	0.888	-173
750	0.946	178	0.81	25	0.008	-15	0.895	-173
800	0.949	177	0.73	22	0.009	-17	0.906	-174
850	0.954	177	0.67	20	0.009	-28	0.912	-175
900	0.953	175	0.61	18	0.007	-34	0.919	-175
950	0.957	175	0.56	15	0.005	-32	0.927	-176
1000	0.957	174	0.51	13	0.004	-22	0.934	-177
1050	0.957	174	0.48	10	0.004	-11	0.939	-178
1100	0.962	173	0.45	8	0.004	-2	0.945	-178
1150	0.959	172	0.41	7	0.004	3	0.950	-179
1200	0.955	171	0.39	4	0.004	9	0.950	-180
1250	0.962	170	0.36	2	0.004	13	0.955	180
1300	0.959	170	0.33	0	0.004	17	0.953	179
1350	0.956	169	0.31	-1	0.004	25	0.954	178
1400	0.954	168	0.29	-4	0.004	32	0.957	177
1450	0.955	168	0.28	-6	0.004	46	0.952	177
1500	0.948	167	0.26	-7	0.004	56	0.948	176

ARCHIVED 2005

NOTES

ARCHIVED 2005

PACKAGE DIMENSIONS

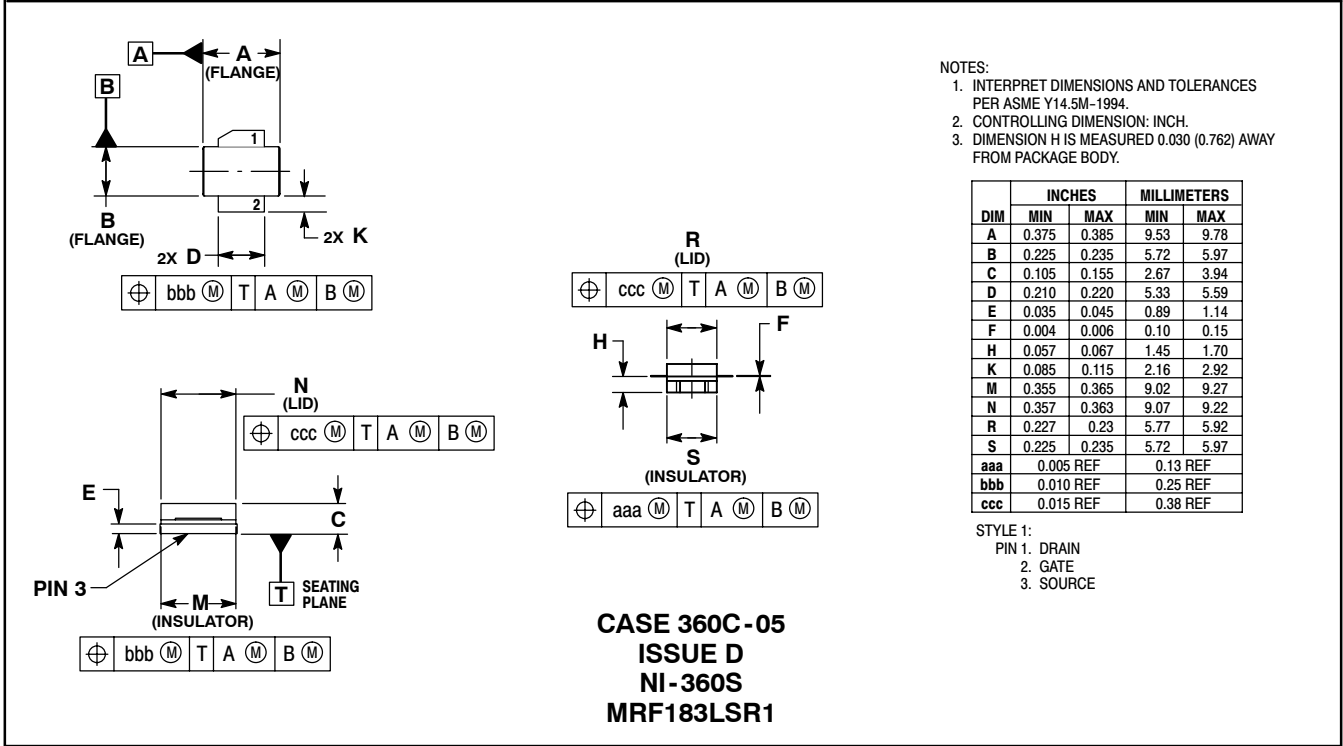
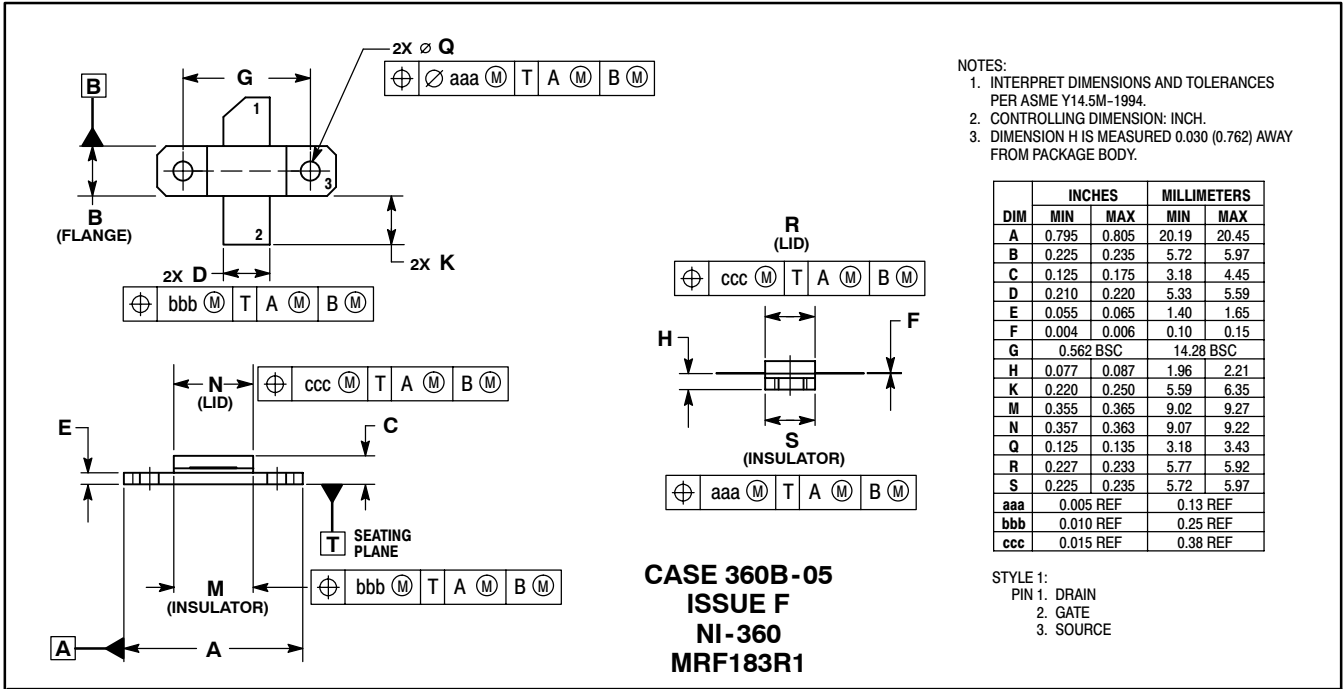

ARCHIVED 2005

Information in this document is provided solely to enable system and software implementers to use Motorola products. There are no express or implied copyright licenses granted hereunder to design or fabricate any integrated circuits or integrated circuits based on the information in this document.

Motorola reserves the right to make changes without further notice to any products herein. Motorola makes no warranty, representation or guarantee regarding the suitability of its products for any particular purpose, nor does Motorola assume any liability arising out of the application or use of any product or circuit, and specifically disclaims any and all liability, including without limitation consequential or incidental damages. "Typical" parameters that may be provided in Motorola data sheets and/or specifications can and do vary in different applications and actual performance may vary over time. All operating parameters, including "Typicals", must be validated for each customer application by customer's technical experts. Motorola does not convey any license under its patent rights nor the rights of others. Motorola products are not designed, intended, or authorized for use as components in systems intended for surgical implant into the body, or other applications intended to support or sustain life, or for any other application in which the failure of the Motorola product could create a situation where personal injury or death may occur. Should Buyer purchase or use Motorola products for any such unintended or unauthorized application, Buyer shall indemnify and hold Motorola and its officers, employees, subsidiaries, affiliates, and distributors harmless against all claims, costs, damages, and expenses, and reasonable attorney fees arising out of, directly or indirectly, any claim of personal injury or death associated with such unintended or unauthorized use, even if such claim alleges that Motorola was negligent regarding the design or manufacture of the part.

MOTOROLA and the Stylized M Logo are registered in the US Patent and Trademark Office. All other product or service names are the property of their respective owners. Motorola, Inc. is an Equal Opportunity/Affirmative Action Employer.

© Motorola Inc. 2003

HOW TO REACH US:

USA/EUROPE/LOCATIONS NOT LISTED:
Motorola Literature Distribution
P.O. Box 5405, Denver, Colorado 80217
1-800-521-6274 or 480-768-2130

JAPAN: Motorola Japan Ltd.; SPS, Technical Information Center,
3-20-1, Minami-Azabu, Minato-ku, Tokyo 106-8573, Japan
81-3-3440-3569

ASIA/PACIFIC: Motorola Semiconductors H.K. Ltd.; Silicon Harbour Centre,
2 Dai King Street, Tai Po Industrial Estate, Tai Po, N.T., Hong Kong
852-26668334

HOME PAGE: <http://motorola.com/semiconductors>

