

1 Watt Ku Band Packaged Amplifier TGA2903-EPU-SG



Key Features and Performance

- Surface Mountable
- Frequency Range: 13 - 17 GHz
- 30 dBm Midband Pout
- 30 dB Nominal Gain
- 15 dB Typical Input Return Loss
- 8 dB Typical Output Return Loss
- 0.5µm pHEMT Technology
- Bias Conditions: 7 V, 430 mA
- Available in Tape & Reel or Waffle Pack
- Package dimensions:
9.4 x 6.4 x 0.1 mm (370 x 250 x 4 mils)

Preliminary Measured Performance

Bias Conditions: Vd=7 V Id=430 mA

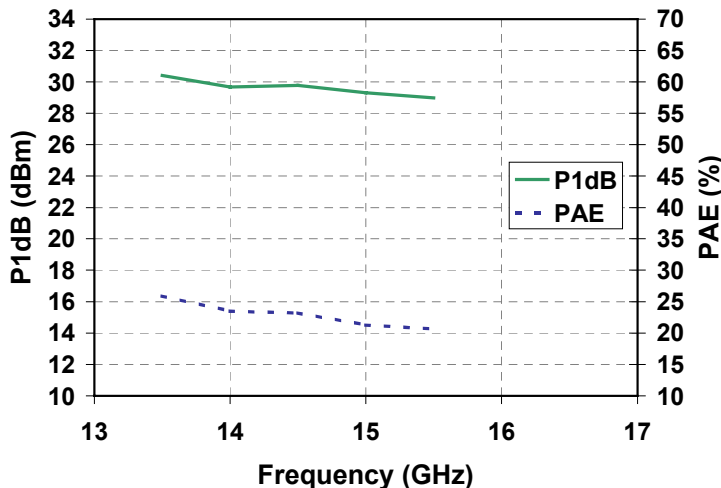
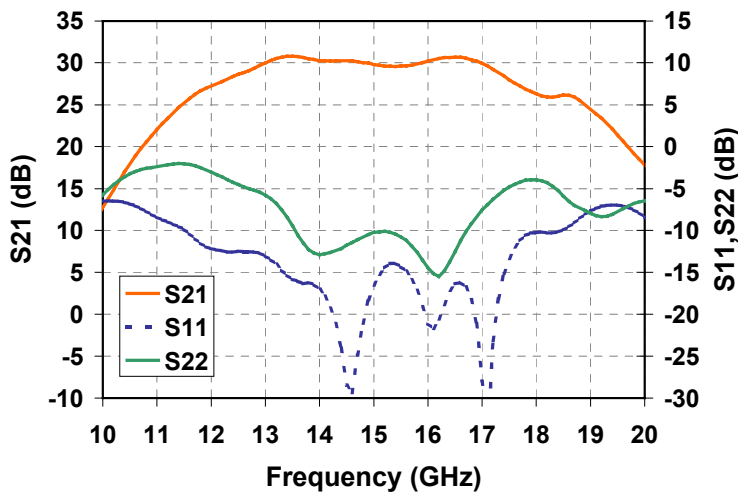

Primary Applications

- VSAT
- Point to Point

Note: Devices designated as EPU are typically early in their characterization process prior to finalizing all electrical and process specifications. Specifications are subject to change without notice.

**TABLE I
MAXIMUM RATINGS**

Symbol	Parameter <u>1/</u>	Value	Notes
V_D	Drain Voltage	8 V	<u>2/</u>
V_G	Gate Voltage Range	-5V to 0V	
I_D	Drain Current (Quiescent)	591 mA	<u>2/</u>
$ I_G $	Gate Current	14 mA	
P_{IN}	Input Continuous Wave Power	17 dBm	<u>2/</u>
P_D	Power Dissipation	TBD	<u>2/</u>
T_{CH}	Operating Channel Temperature	150 °C	<u>3/ 4/</u>
T_M	Mounting Temperature (30 Seconds)	320 °C	
T_{STG}	Storage Temperature	-65 to 150 °C	

- 1/ These ratings represent the maximum operable values for this device.
- 2/ Combinations of drain voltage, drain current, input power and output power shall not exceed P_D .
- 3/ These ratings apply to each individual FET.
- 4/ Junction operating temperature will directly affect the device median time to failure (T_M). For maximum life, it is recommended that junction temperatures be maintained at the lowest possible levels.

Note: Devices designated as EPU are typically early in their characterization process prior to finalizing all electrical and process specifications. Specifications are subject to change without notice.

TABLE II
RF CHARACTERIZATION TABLE
($T_A = 25^\circ\text{C}$, Nominal)
($V_d = 7\text{V}$, $I_d = 430\text{mA} \pm 5\%$)

SYMBOL	PARAMETER	TEST CONDITION	LIMITS			UNITS
			MIN	TYP	MAX	
Gain	Small Signal Gain	F = 13-17GHz		30		dB
IRL	Input Return Loss	F = 13-17GHz		15		dB
ORL	Output Return Loss	F = 13-17GHz		10		dB
PWR	Output Power @ P1dB	F = 13-17GHz		30		dBm
PAE	Power Added Efficiency @ P1dB	F = 13-17GHz		22		%

Note: Table III Lists the RF Characteristics of typical devices as determined by fixtured measurements.

Note: Devices designated as EPU are typically early in their characterization process prior to finalizing all electrical and process specifications. Specifications are subject to change without notice.

Typical Fixtured Performance

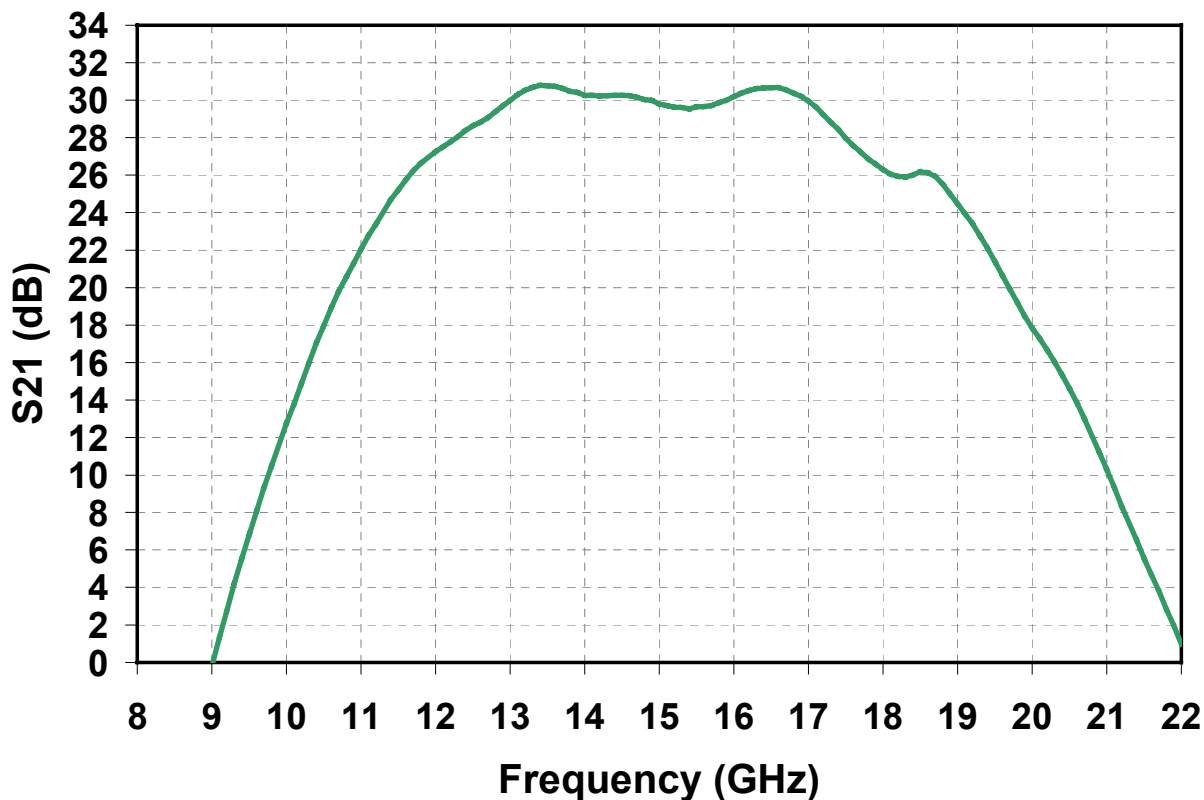
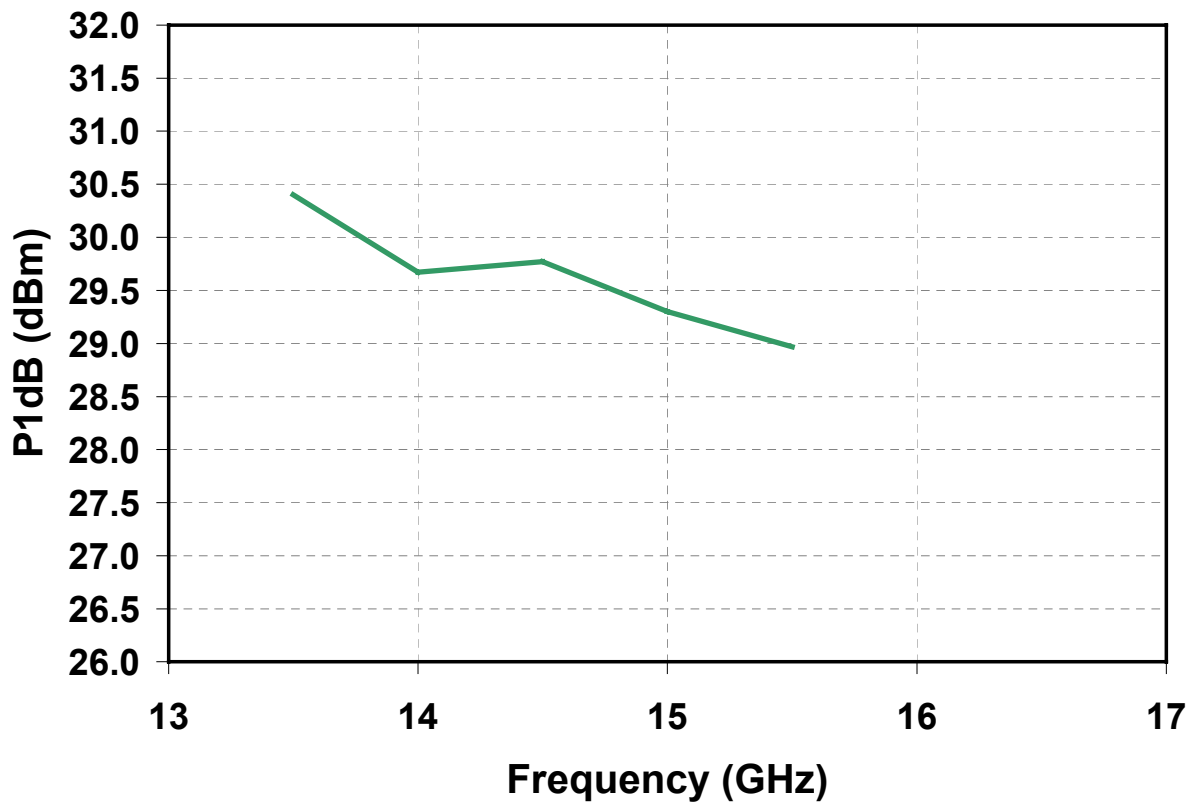

Note: Devices designated as EPU are typically early in their characterization process prior to finalizing all electrical and process specifications. Specifications are subject to change without notice.

Typical Fixtured Performance

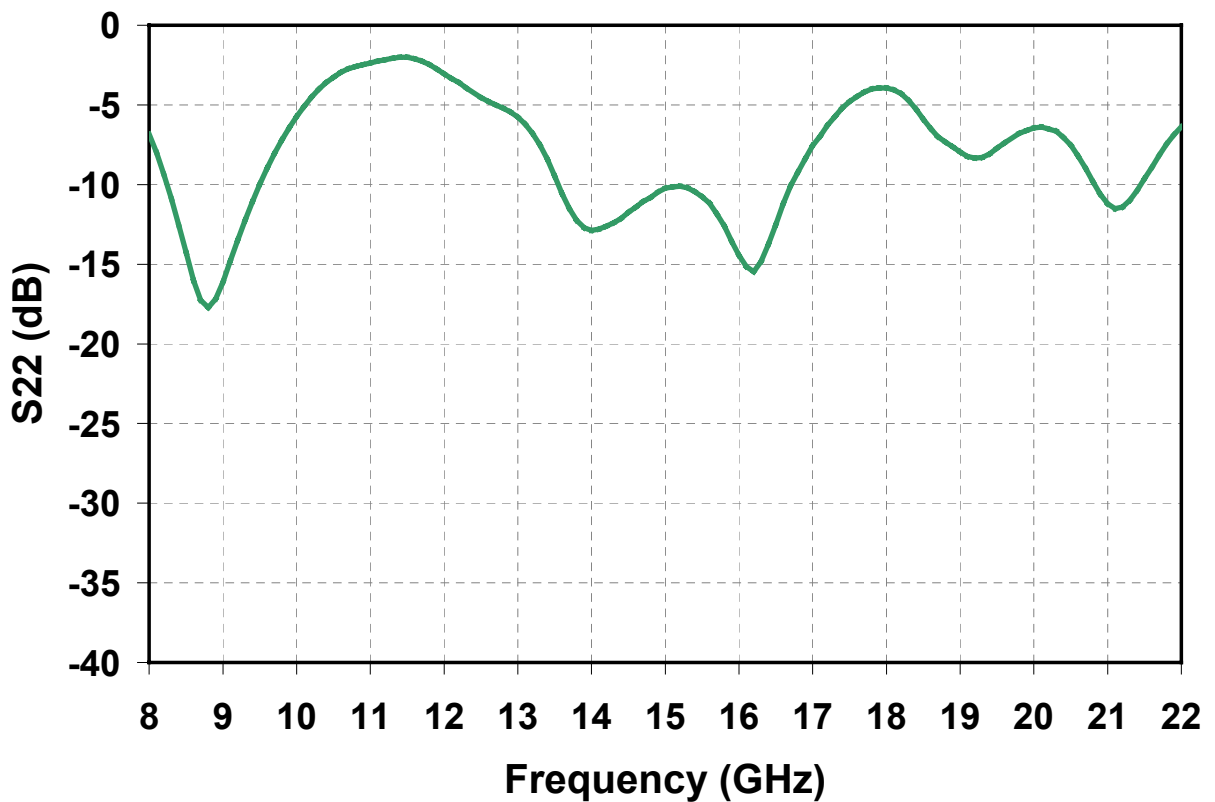
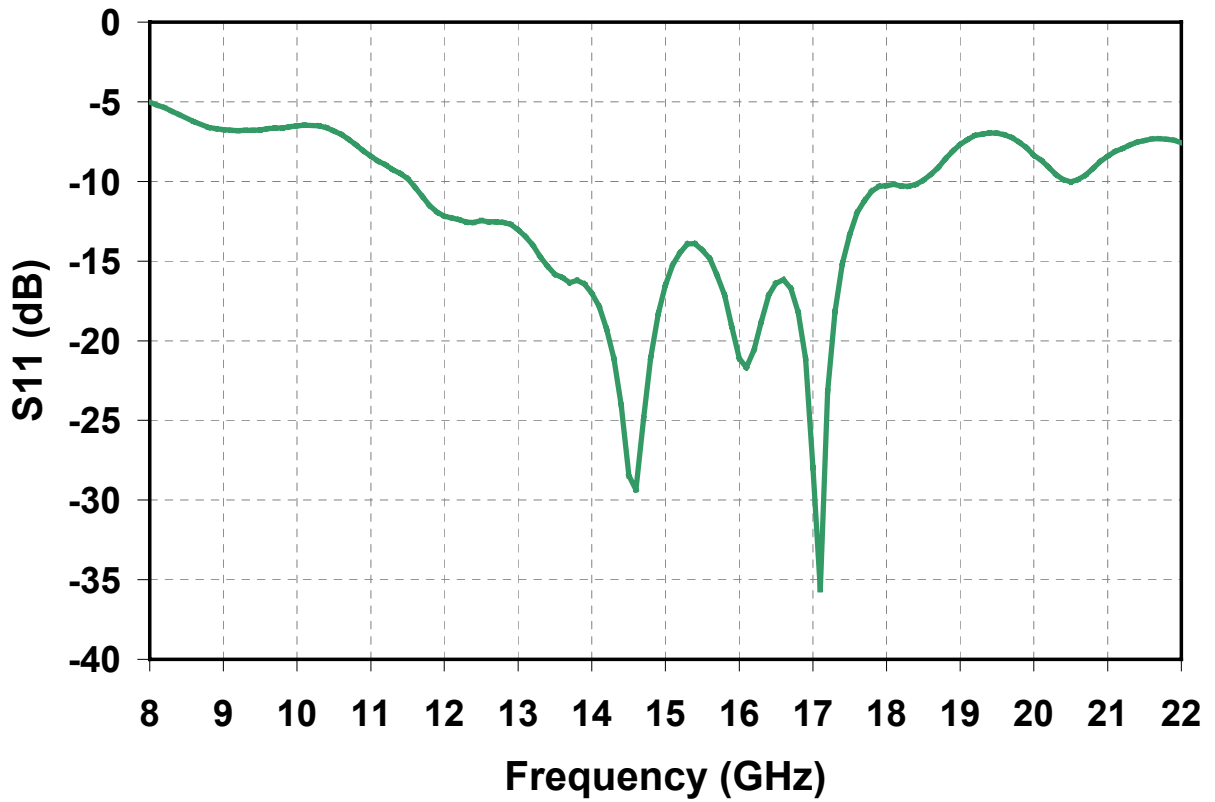

Note: Devices designated as EPU are typically early in their characterization process prior to finalizing all electrical and process specifications. Specifications are subject to change without notice.

Typical Fixtured Performance

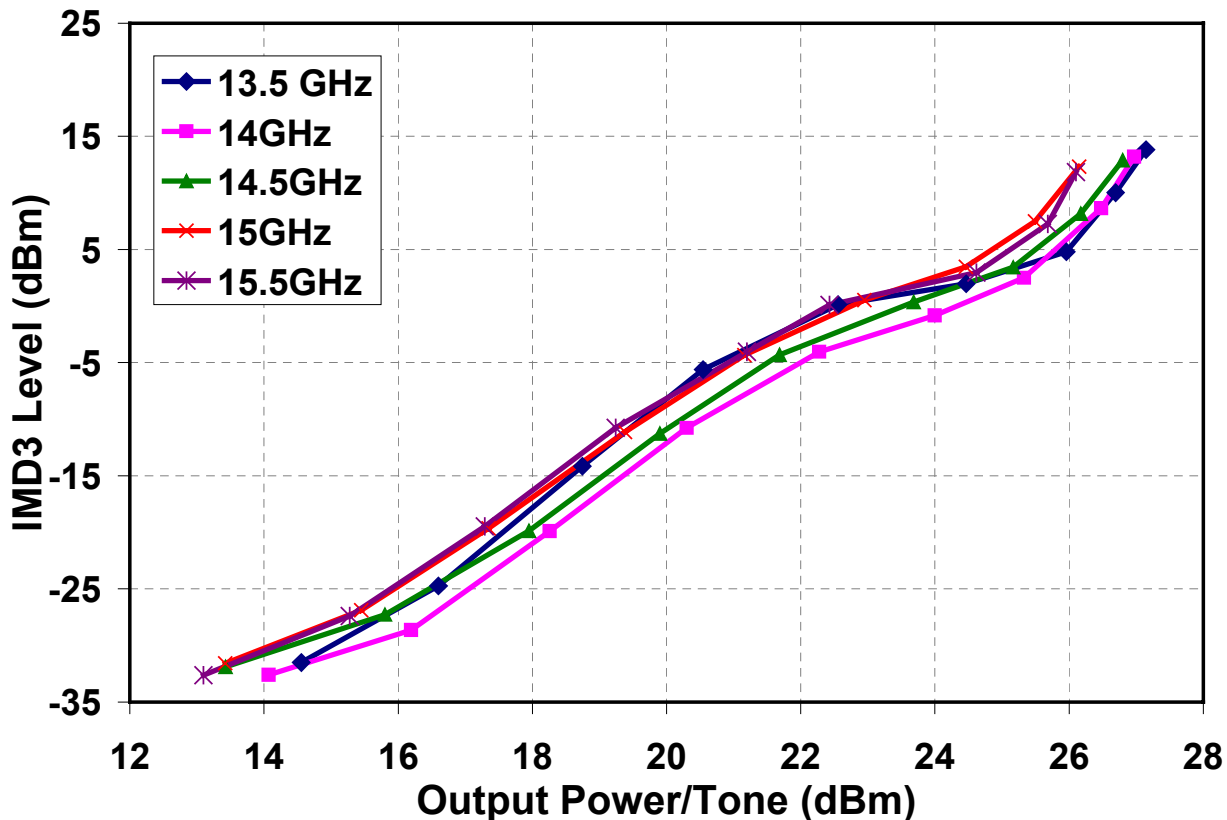
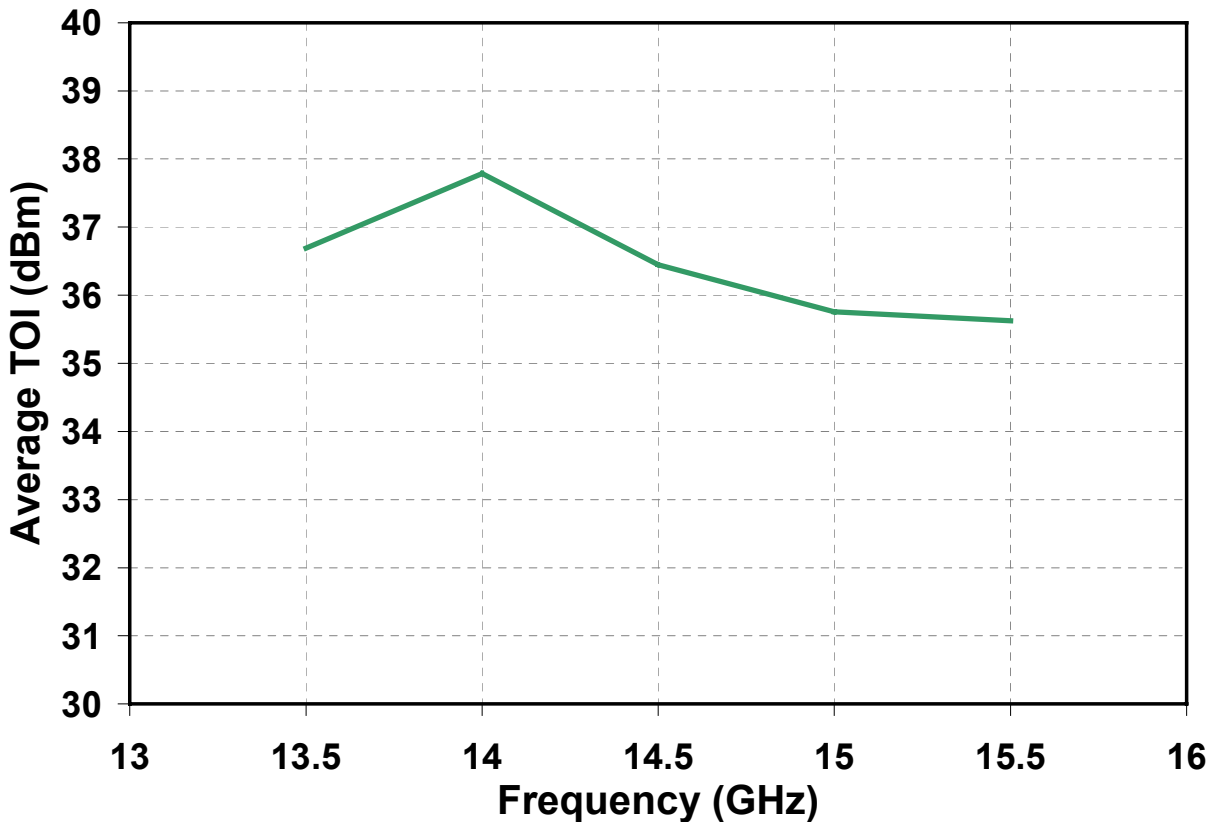

Note: Devices designated as EPU are typically early in their characterization process prior to finalizing all electrical and process specifications. Specifications are subject to change without notice.

Package Pinout Diagram

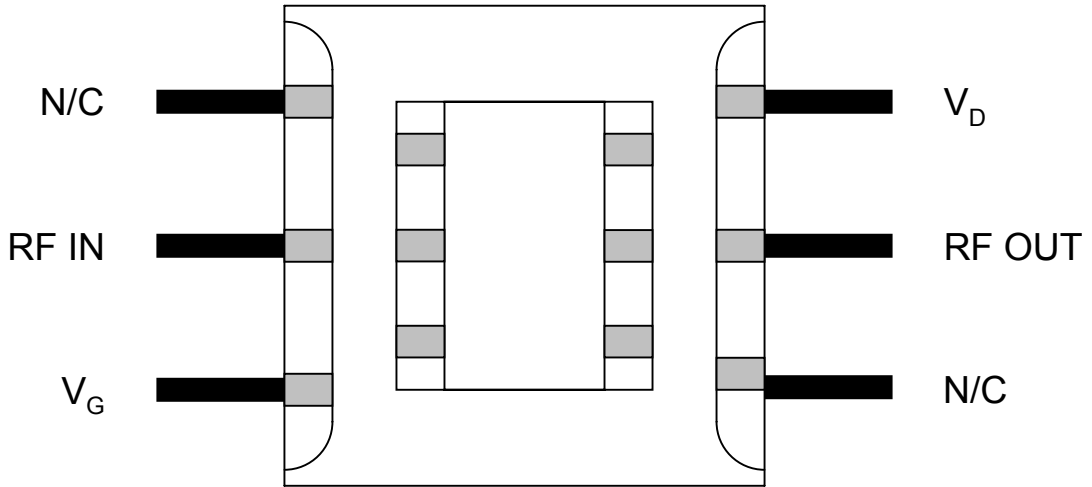

GaAs MMIC devices are susceptible to damage from Electrostatic Discharge. Proper precautions should be observed during handling, assembly and test.

Note: Devices designated as EPU are typically early in their characterization process prior to finalizing all electrical and process specifications. Specifications are subject to change without notice.

Mechanical Drawing

Dimensions in inches

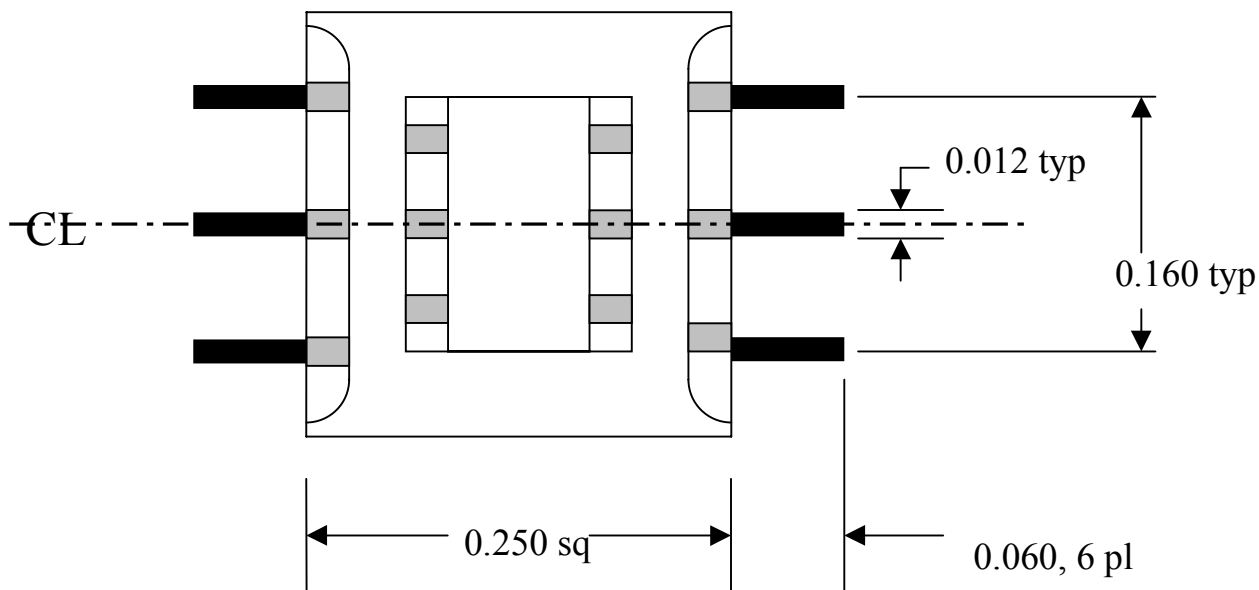

Top View

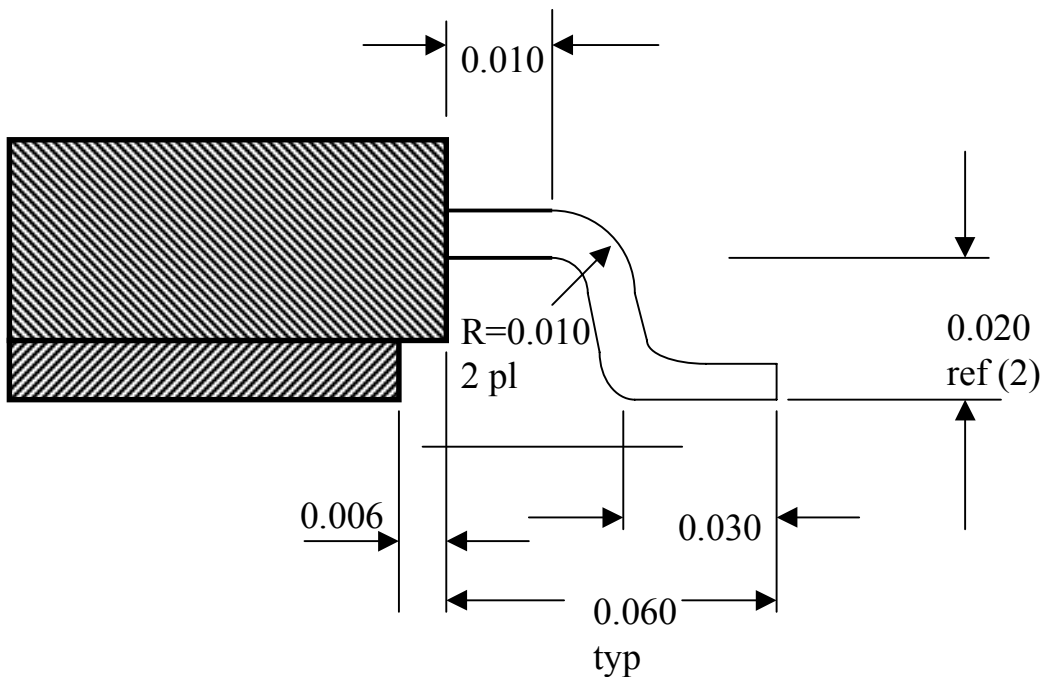

Side View

Note: Devices designated as EPU are typically early in their characterization process prior to finalizing all electrical and process specifications. Specifications are subject to change without notice.

Recommended PWB Land Pattern

Dimensions in inches

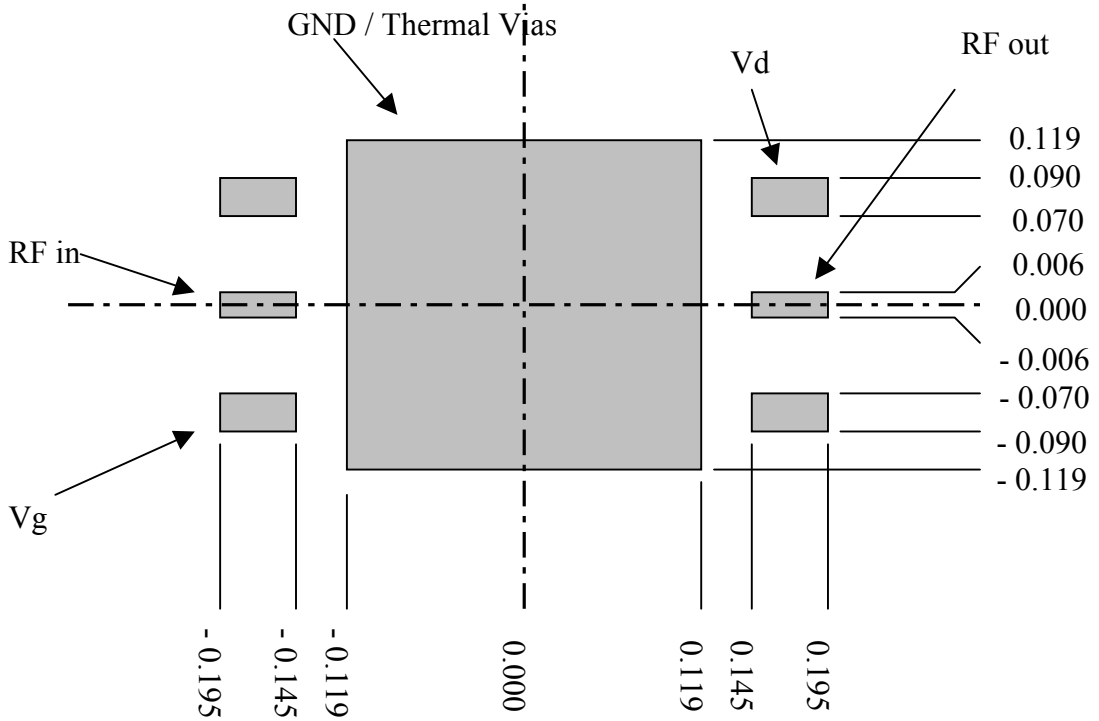

Note: Devices designated as EPU are typically early in their characterization process prior to finalizing all electrical and process specifications. Specifications are subject to change without notice.