

300mA Low-Noise Ultra Low-Dropout CMOS Regulator with $\overline{\text{Fault}}$ Indicator

DESCRIPTION

The EUP7982 low-noise, low-dropout, linear regulator operates from a 2.5V to 5.5V input and is guaranteed to deliver 300mA.

The EUP7982 is stable with small 2.2 μ F ceramic capacitor. Its performance suits battery powered applications because of its shutdown mode (60 nA typ), low quiescent current (110 μ A typ), and LDO voltage (140mV typ). The low dropout voltage allows for more utilization of a battery's available energy by operating closer to its end-of-life voltage. An output fault-detection circuit indicates loss of regulation.

The EUP7982 is available in MSOP package with 1.8V, 2.5v, 2.8V, 3V, 3.3V, and adjustable versions.

FEATURE

- 2.5V to 5.5V Input Range
- 300mA Guaranteed Output Current
- 60dB PSRR at 1kHz
- 50 μ V RMS Output Voltage Noise (10Hz to 100kHz)
- 140mV Dropout at 300mA
- Low 110 μ A No-Load Supply Current
- $\leq 1\mu$ A Shutdown Current
- Fast Start-up Time
- Stable With 2.2 μ F Ceramic Output Capacitors
- Thermal Shutdown and Short-Circuit Protection
- Fault Indicator
- RoHS Compliant and 100% Lead (Pb)-Free

APPLICATIONS

- Wireless Handsets
- DSP Core Power
- Battery Powered Electronics
- Portable Information Appliances

Block Diagram

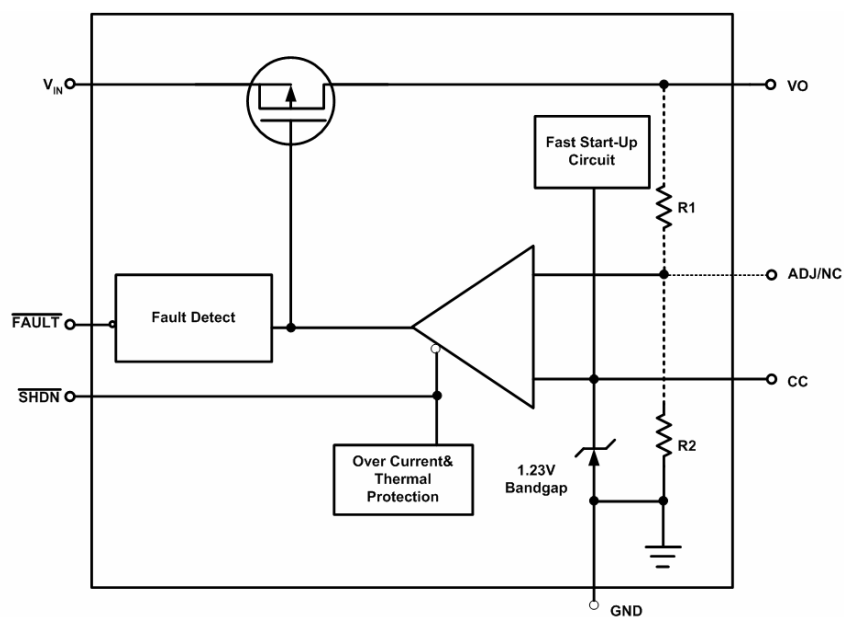
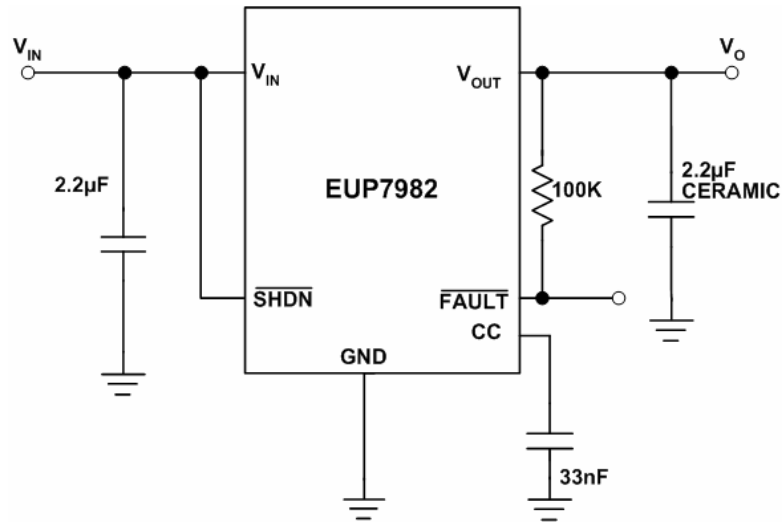

Figure1.

Typical Application Circuit



www.DataSheet4U.com

Figure2. Fixed Voltage LDO Regulator

Pin Configurations

Part Number	Pin Configurations
EUP7982 MSOP-8	<p style="text-align: center;">8-Pin MSOP</p>

Pin Description

PIN	PIN	DESCRIPTION
OUT	1,4	Output voltage of the LDO
IN	2	Input voltage of the LDO
GND	3	Common Ground
SET	5	Output voltage set. Not externally connected for the fixed versions. Connect ot resistor-divider for adjustable output voltage.
CC	6	Compensation capacitor for noise reduction
SHDN	7	SHDN places the entire device in shutdown mode when held low.
FAULT	8	Fault output. A high-impedance, open-drain output. If the circuit is out of regulation, FAULT goes low. In shutdown, this pin is high Impedance. Connect to GND if unused

Ordering Information

Order Number	Package Type	Marking	Operating Temperature range
EUP7982MIR1 EUP7982MIR0	MSOP-8	CA P7982	-40°C to 85°C
EUP7982-18MIR1 EUP7982-18MIR0	MSOP-8	C1 P7982	-40°C to 85°C
EUP7982-25MIR1 EUP7982-25MIR0	MSOP-8	C2 P7982	-40°C to 85°C
EUP7982-28MIR1 EUP7982-28MIR0	MSOP-8	C6 P7982	-40°C to 85°C
EUP7982-30MIR1 EUP7982-30MIR0	MSOP-8	C5 P7982	-40°C to 85°C
EUP7982-33MIR1 EUP7982-33MIR0	MSOP-8	C3 P7982	-40°C to 85°C

EUP7982

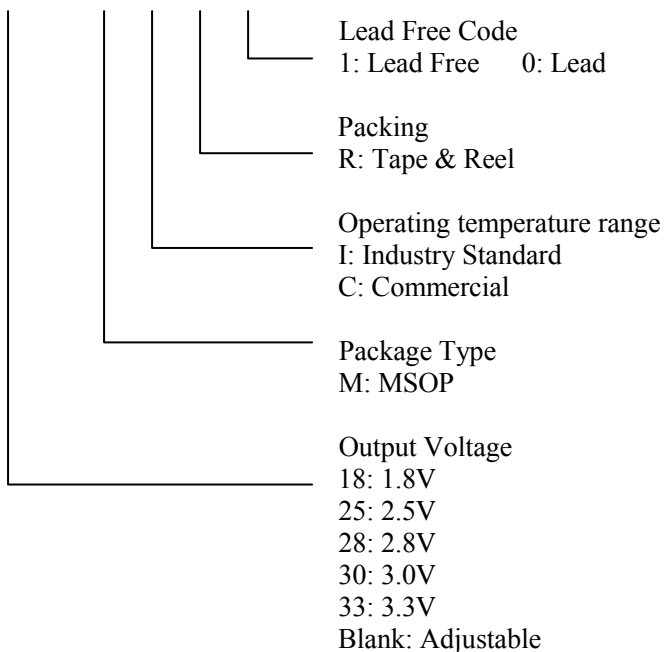

Absolute Maximum Ratings

- $V_{IN}, V_{OUT}, \overline{V_{SHDN}}, \overline{V_{SET}}, V_{CC}, \overline{V_{FAULT}}$ ----- -0.3V to 6V
- Fault Sink Current ----- 20mA
- Storage Temperature Range ----- -65°C to 160°C
- Junction Temperature (T_J) ----- 150°C
- Lead Temperature (10 sec.) ----- 260°C

Electrical Characteristics

Unless otherwise specified, all limits guaranteed for $V_{IN}=V_O+0.5V$, $\overline{V_{SHDN}}=V_{IN}$, $C_{IN}=C_{OUT}=2.2\mu F$, $C_{CC}=22nF$, $T_J=25^\circ C$. (Boldface limits apply for the operating temperature extremes: -40°C and 85°C)

Symbol	Parameter	Conditions	EUP7982			Unit
			Min	Typ	Max.	
V_{IN}	Input Voltage		2.5		5.5	V
ΔV_O	Output Voltage Tolerance	$100\mu A \leq I_{OUT} \leq 300mA$ $V_{IN}=V_O+0.5V$, SET= OUT for the Adjust Versions	-2 -3		+2 +3	% of $V_{OUT(NOM)}$
V_O	Output Adjust Range	Adjust Version Only	1.25		5.5	V
I_O	Maximum Output Current	Average DC Current Rating	300			mA
I_{LIMIT}	Output Current Limit			600		mA
I_Q	Supply Current	$I_{OUT}=0mA$ $I_{OUT}=300mA$		110 240	200	μA
	Shutdown Supply Current	$V_O=0V$, $\overline{SHDN}=GND$		0.06	1	μA
V_{DO}	Dropout Voltage	$I_{OUT}=1mA$		0.4		mV
		$I_{OUT}=200mA$		90	200	
		$I_{OUT}=300mA$		140		
ΔV_O	Line Regulation	$I_{OUT}=1mA$, $(V_O+0.5V) \leq V_I \leq 5.5V$	-0.1	0.05	0.1	%/V
	Load Regulation	$100\mu A \leq I_{OUT} \leq 300mA$		0.002		%/mA
e_n	Output Voltage Noise	$I_{OUT}=10mA$, $10Hz \leq f \leq 100kHz$		50		μV_{RMS}
$\overline{V_{SHDN}}$	SHDN Input Threshold	$V_{IH}(V_O+0.5V) \leq V_I \leq 5.5V$	2			V
		$V_{IL}(V_O+0.5V) \leq V_I \leq 5.5V$			0.4	
$\overline{I_{SHDN}}$	SHDN Input Bias Current	$\overline{SHDN}=GND$ or IN		0.1	100	nA
$\overline{I_{SET}}$	SET Input Leakage	SET = 1.3V, Adjust Version Only		0.1	2.5	nA
$\overline{V_{FAULT}}$	FAULT Detection Voltage	$V_O \geq 2.5V$, $I_{OUT}=200mA$		150	280	mV
	FAULT Output Low Voltage	$I_{SINK}=2mA$		0.13	0.25	V
$\overline{I_{FAULT}}$	FAULT Off-Leakage Current	FAULT =3.6V, $\overline{SHDN}=0V$		0.1	100	nA
T_{SD}	Thermal Shutdown Temperature			160		°C
	Thermal Shutdown Hysteresis			20		
T_{ON}	Start-Up Time	$C_{OUT}=10\mu F$, V_O at 90% of Final Value		80		μs

Typical Operating Characteristics

Unless otherwise specified, $V_{IN} = V_O + 0.5V$, $C_{IN}=C_{OUT} = 2.2 \mu F$, $C_{CC}= 22 nF$, $T_J= 25^\circ C$, $V_{SHDN}=V_{IN}$

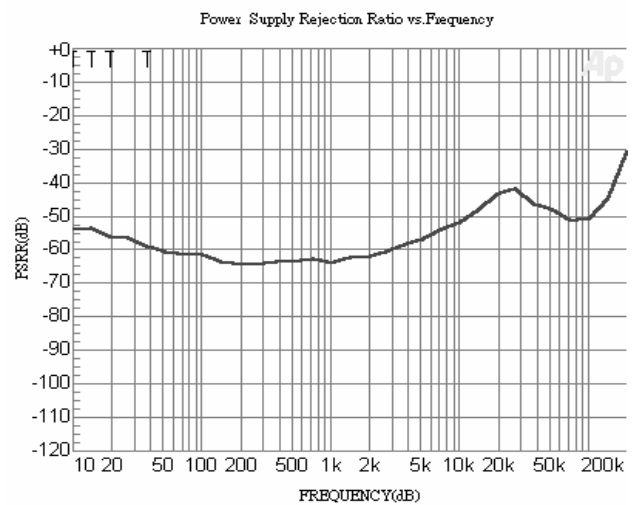
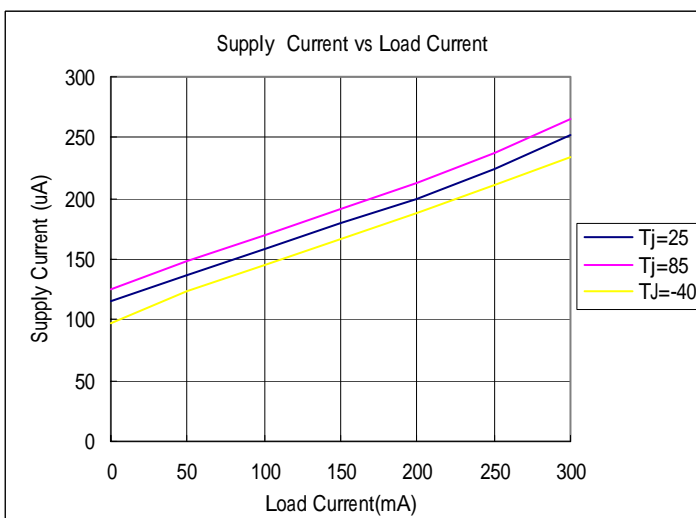
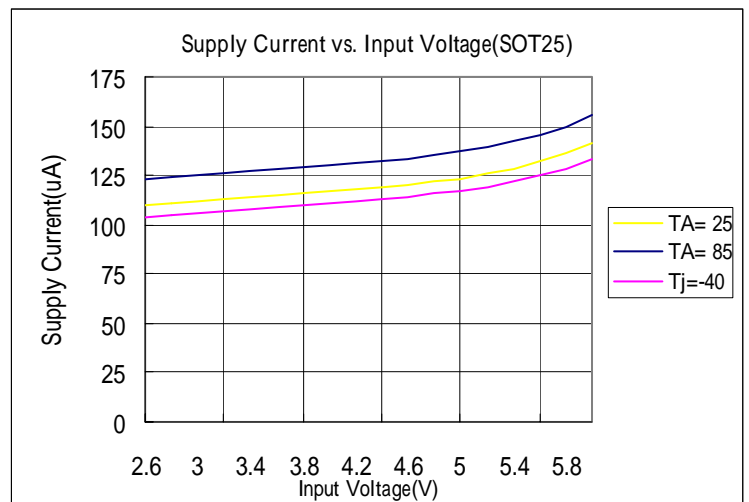
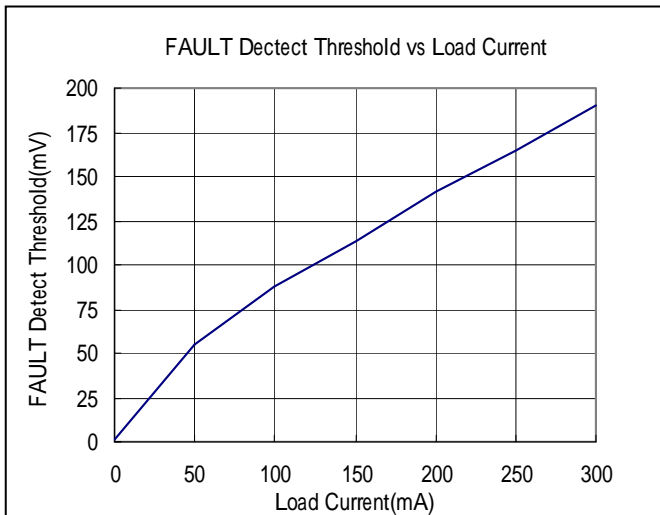
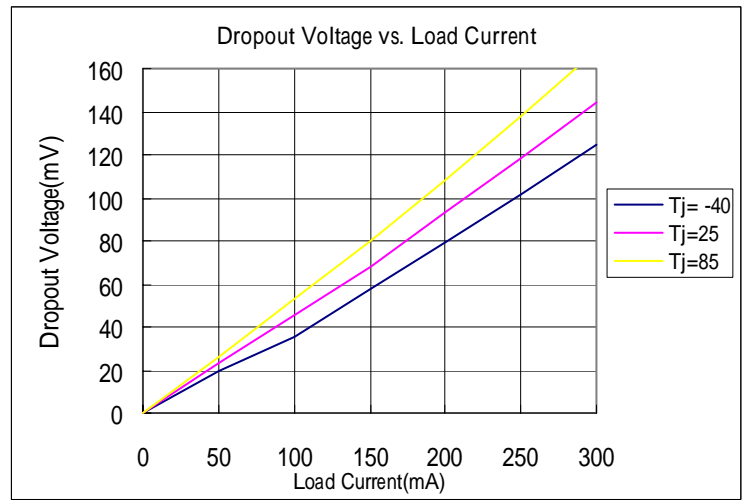
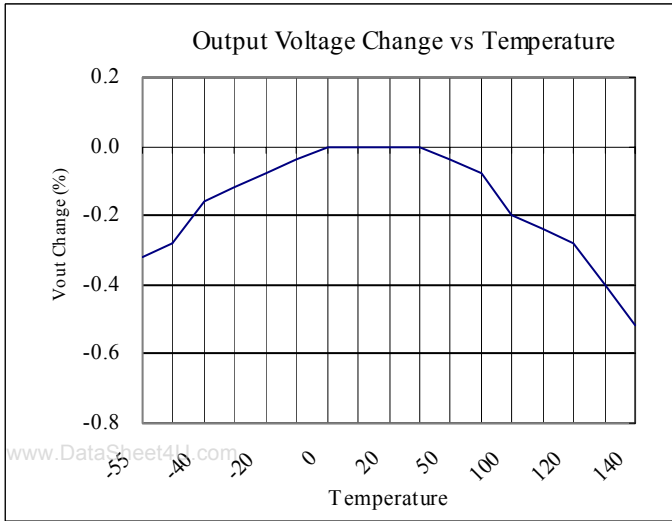

Output Noise (10kHz to 100kHz)

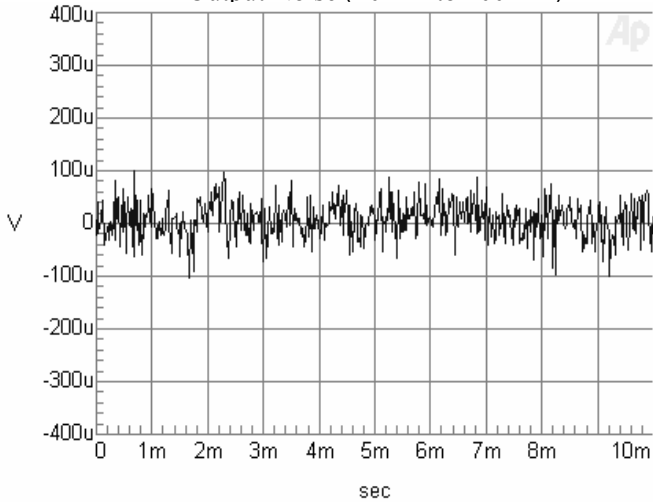

www.DataSheet4U.com

Line Transient Response

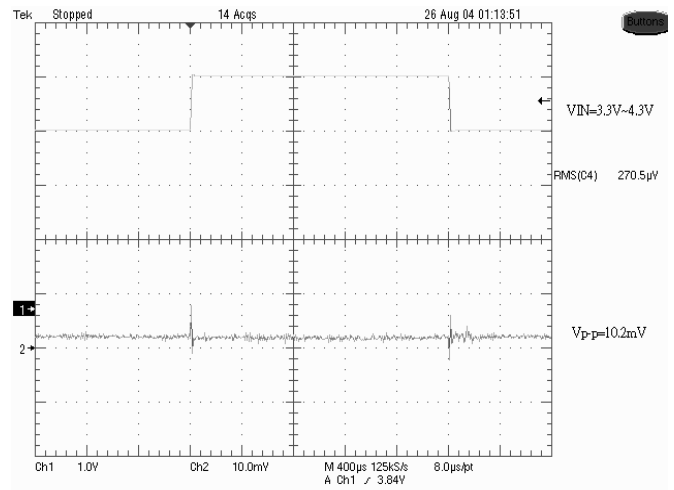

Load Transient

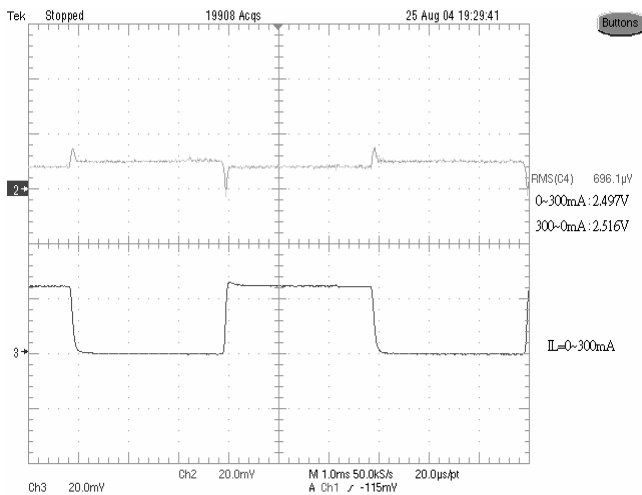

Shutdown Response

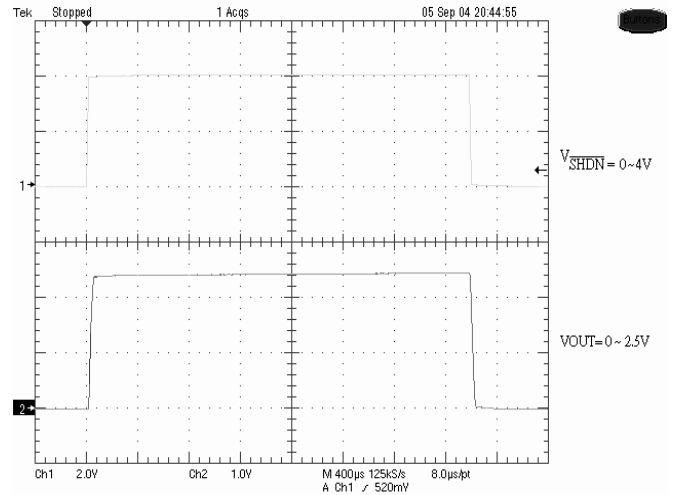

Power-up Response

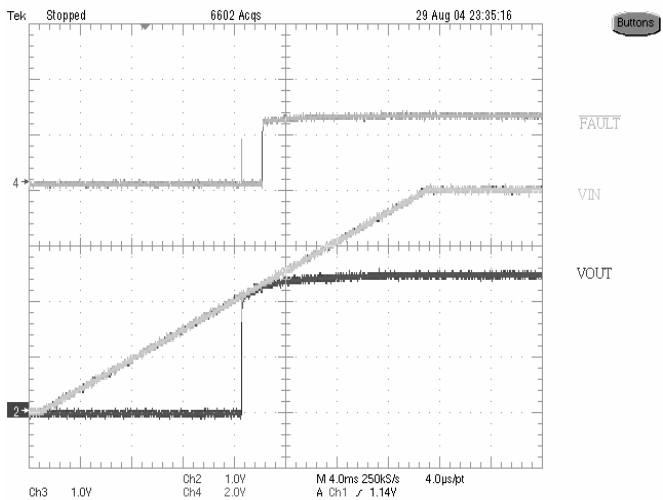

Power-down Response

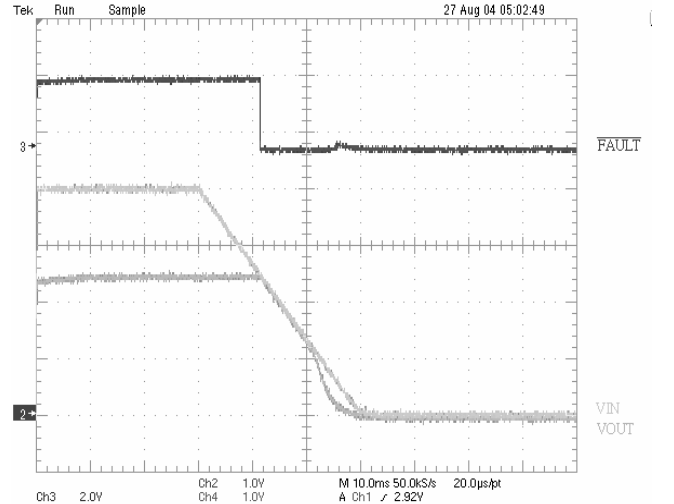

Application Information

External Capacitors

Like any low-dropout regulator, the EUP7982 requires external capacitors for regulator stability. The EUP7982 is specifically designed for portable applications requiring minimum board space and smallest components. These capacitors must be correctly selected for good performance.

Input Capacitor

A minimum input capacitance of 1 μ F is required between the EUP7982 input pin and ground (the amount of the capacitance may be increased without limit). This capacitor must be located a distance of not more than 1cm from the input pin and returned to a clean analog ground.

www.DataSheet4U.com
1 μ F ceramic capacitor are fine for most end use applications. If a tantalum capacitor is used at the input, it must be guaranteed by the manufacturer to have a surge current rating sufficient for the application.

No-Load Stability

The EUP7982 will remain stable and in regulation with no external load. This is specially important in CMOS RAM keep-alive applications.

Output Capacitance

The EUP7982 is specifically designed to employ ceramic output capacitors as low as 2.2 μ F. Ceramic capacitors below 10 μ F offer significant cost and space savings, along with high frequency noise filtering. Higher values and other types and of capacitor may be used, but their equivalent series resistance (ESR) should be maintained below 0.5 Ω . Ceramic capacitor of the value required by the EUP7982 are available in the following dielectric types: Z5U, Y5V, X5R, and X7R. The Z5U and Y5V types exhibit a 50% or more drop in capacitance value as their temperature increase from 25 $^{\circ}$ C, an important consideration. The X5R generally maintain their capacitance value within \pm 20%. The X7R type are desirable for their tighter tolerance of 10% over temperature.

Noise Bypass Capacitor

Connecting a 33nF capacitor between the C_{BYPASS} pin and ground significantly reduces noise on the regulator output. This cap is connected directly to a high impedance node in the bandgap reference circuit. Any significant loading on this node will cause a change on the regulated output voltage. For this reason, DC leakage current through this pin must be kept as low as possible for best output voltage accuracy. The types of capacitors best suited for the noise bypass capacitor are ceramic and film.

Unlike many other LDO's, addition of a noise reduction capacitor does not effect the load transient response of the device. However, it does affect start-up time. The smaller the capacitance value, the quicker the start-up time.

Power Dissipation and Junction Temperature

Specified regulator operation is assured to a junction temperature of 125 $^{\circ}$ C; the maximum junction temperature should be restricted to 125 $^{\circ}$ C under normal operating conditions. This restriction limits the power dissipation the regulator can handle in any given application. To ensure the junction temperature is within acceptable limits, calculate the maximum allowable dissipation, P_{D(max)}, and the actual dissipation, P_D, which must be less than or equal to P_{D(max)}.

The maximum-power-dissipation limit is determined using the following equation:

$$P_{D(max)} = \frac{T_{Jmax} - T_A}{R_{\theta JA}}$$

Where:

T_{Jmax} is the maximum allowable junction temperature.

R _{θ JA} is the thermal resistance junction-to-ambient for the package

T_A is the ambient temperature.

The regulator dissipation is calculated using:

$$P_D = (V_I - V_O) \times I_O$$

Power dissipation resulting from quiescent current is negligible. Excessive power dissipation triggers the thermal protection circuit.

Adjustable Operation

The adjustable version of the EUP7982 has an output voltage range of 1.25V to 6V. The output voltage of the EUP7982 adjustable regulator is programmed using an external resistor divider as shown in Figure3. The output voltage is calculated using:

$$V_O = V_{ref} \times \left(1 + \frac{R_1}{R_2}\right)$$

Where:

Vref=1.23V typ. (the internal reference voltage)

Utilize the following equation for adjusting the output to a particular voltage:

$$R_1 = R_2 \left[\frac{V_O}{1.23V} - 1 \right]$$

Choose R₂=100k to optimize accuracy, power supply rejection, noise and power consumption.

In order to improve the stability of the adjustable version, it is suggested that a small compensation capacitor C₁ be placed between OUT and SET

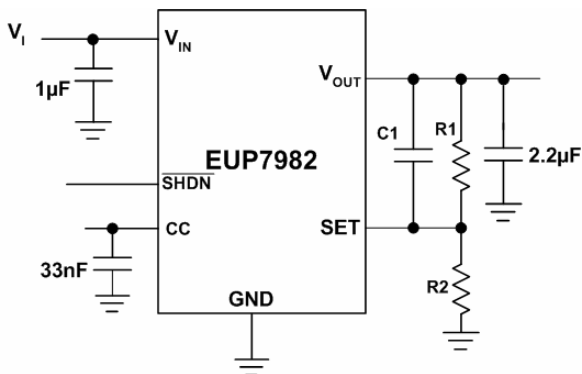

Figure3. Adjustable LDO Regulator Programming

Fault Detection

The EUP7982 provides a FAULT pin that goes low during out of regulation conditions like current limit and thermal shutdown, or when it approaches dropout. The latter monitors the input-to-output voltage differential and compares it against a threshold that is slightly above the dropout voltage. This threshold also tracks the dropout voltage as it varies with load current. Refer to Fault Detect vs. Load Current curve in the typical characteristics section.

The FAULT pin requires a pull-up resistor since it is an open-drain output. This resistor should be large in value to reduce energy drain. A100kΩ pull-up resistor works well for most applications.

Shutdown

The EUP7982 goes into sleep mode when the SHDN pin is in a logic low condition. During this condition, the pass transistor, error amplifier, and bandgap are turned off, reducing the supply current to 60nA typical. The SHDN pin may be directly tied to VIN to keep the part on.

Fast Start-up

The EUP7982 provides fast start-up time for better system efficiency. The start-up speed is maintained when using the optional noise bypass capacitor.

Packaging Information

MSOP-8

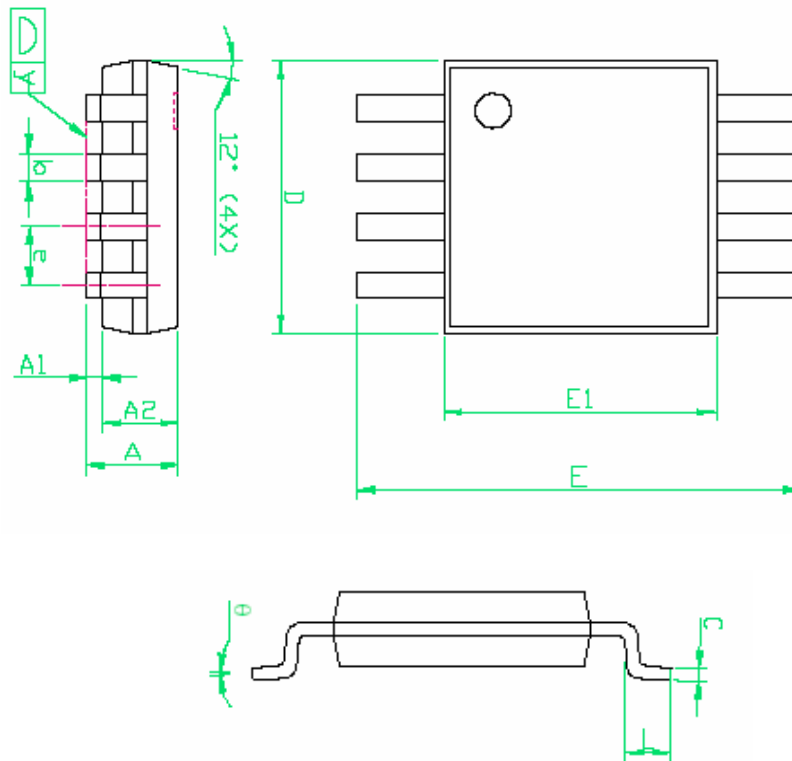

www.DataSheet4U.com

NOTE

1. Package body sizes exclude mold flash and gate burrs
2. Dimension L is measured in gage plane
3. Tolerance 0.10mm unless otherwise specified
4. Controlling dimension is millimeter. Converted inch dimensions are not necessarily exact.

SYMBOLS	DIMENSIONS IN MILLIMETERS			DIMENSIONS IN INCHES		
	MIN.	NOM.	MAX.	MIN.	NOM.	MAX.
A	0.81	0.95	1.10	0.032	0.0375	0.043
A1	0.05	0.09	0.15	0.002	0.004	0.006
A2	0.76	0.86	0.97	0.030	0.034	0.038
b	0.28	0.30	0.38	0.011	0.012	0.015
C	0.13	0.15	0.23	0.005	0.006	0.009
D	2.90	3.00	3.10	0.114	0.118	0.122
E	4.70	4.90	5.10	0.185	0.193	0.201
E1	2.90	3.00	3.10	0.114	0.118	0.122
e	-----	0.65	-----	-----	0.026	-----
L	0.40	0.53	0.66	0.016	0.021	0.026
y	-----	-----	0.10	-----	-----	0.004
	0	-----	6	0	-----	6