

### Low-Battery Indicator Has Low Cost and High Efficiency

The circuit described uses a low-power CMOS comparator to provide an LED visual indication of a low-battery condition, without excessive battery current drain. This is achieved by pulsing the LED at a low frequency and low duty cycle and conserving battery current in the OFF cycle by placing the comparator in shutdown. Equations and circuit analysis are included for determining duty cycle and comparator trip points.

The usual method for implementing the low-battery warning featured in most battery-operated equipment is to illuminate an LED. By drawing current, however, the LED exacerbates the low-battery condition. You can greatly reduce the LED's power consumption by operating it at a low frequency and a low duty cycle.

An existing low-battery output (LBO) like that found on DC-DC converters offers a convenient way to light the LED (Figure 1). IC1 is a small, inexpensive comparator with shutdown capability in a 6-pin SC70 package. It remains in shutdown while the battery voltage is at normal operating levels, but asserts LBO when battery voltage falls below a preset threshold.

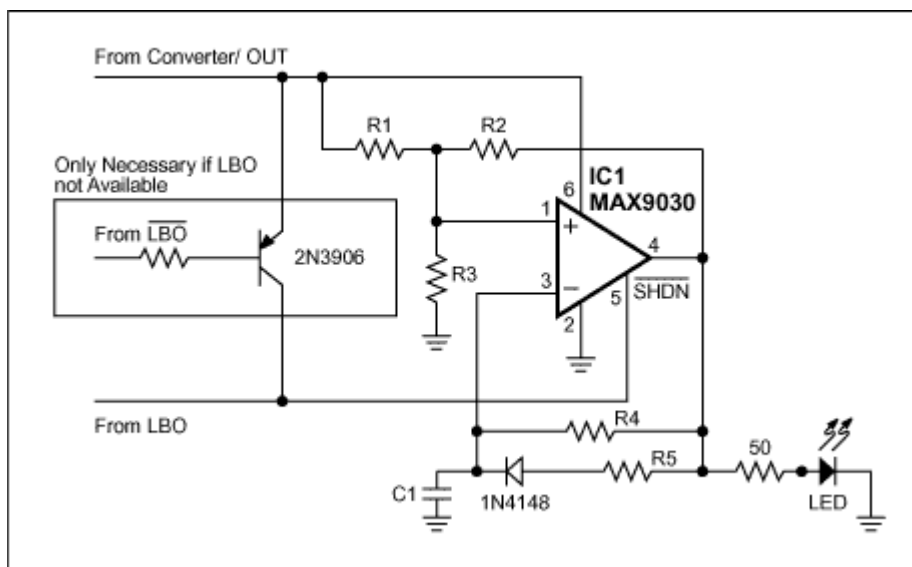

Figure 1. Operating this low-battery-warning LED at low frequency and low duty cycle saves power and extends battery life.

Note that LBO (active high) is usable as shown, but an active-low warning (LBO-bar) requires the optional circuitry shown in the box. IC1 then turns on, causing the LED to flash in accordance with the following analysis:

First, keep the duty cycle low:

$$DC = t_{ON}/(t_{ON} + t_{OFF}).$$

On-time is derived from the equation for time-varying voltage across a charging capacitor:

$$V(t) = V(1 - e^{-t/RC}).$$
$$t_{ON} = -R_5C \ln(1 - V_{TRIPHI}/V_{OUT}).$$

Off-time is derived from the equation for time-varying voltage across a discharging capacitor:

$$V(t) = Ve^{-t/RC}.$$
$$t_{OFF} = -R_4C \ln(V_{TRIPLO}/V_{OUT}).$$

The comparator's high and low trip levels are found using Kirchoff's current laws:

$$V_{TRIPHI} = V_{OUT}[R_3(R_1 + R_2)] / [R_3(R_1 + R_2) + R_1R_2].$$
$$V_{TRIPLO} = V_{OUT}[R_3R_2] / [R_3(R_1 + R_2) + R_1R_2].$$

The typical  $V_{OUT}$  for a comparator is  $V_{DD}$ . Assuming a 2.5% duty cycle, and assuming that LBO trips the comparator on when battery voltage equals 3V, the resulting trip levels are 1V for low and 2V for high. The standard component values corresponding to this performance are:

$$C1 = 0.1\mu F$$
$$R1 = R2 = R3 = 1M\Omega$$
$$R4 = 3.6M\Omega$$
$$R5 = 91k\Omega.$$

The circuit accommodates any type of LBO output (active high or active low). Supply current drawn by IC1 is typically 35 $\mu$ A when active and only 0.05 $\mu$ A while in shutdown. The circuit's small size, low power consumption, and low cost are ideal for battery-powered systems.

A similar version of this article appeared in the May 3, 2001 issue of *EDN* magazine.

## MORE INFORMATION

MAX9030: [QuickView](#) -- [Full \(PDF\) Data Sheet \(360k\)](#) -- [Free Sample](#)