



DESCRIPTION

The ES6230 Vibratto™II processor is a highly integrated single-chip DVD solution that integrates read channel, ECC, Servo DSP, MCU, and MPEG-2 decoder that has a state-of-the-art 480p/576p progressive-scan video feature to provide brilliant and sharp, flicker-free video output, and S/PDIF input and output support. The ES6230 performs audio/video stream data processing, TV encoding, Macrovision™ copy protection, DVD system navigation, system control, and housekeeping functions.

The Vibratto-II DVD processor is built on the ESS proprietary dual CPU Programmable Multimedia Processor (PMP) core consisting of 32-bit RISC and 64-bit DSP processors and offers the best DVD feature set. The processing units enable simultaneous parallel execution of system commands and data processing to perform specialized encoding and decoding tasks.

The RISC processor performs bit stream parsing, control audio data output, transfer video and audio data to the vector engine and service system control and housekeeping functions. The vector engine performs audio and video micro-code processing required by A/V standards, such as Dolby® Digital, DTS™ surround, MPEG and JPEG imaging. These processing tasks include video motion compensation and estimation, loop filtering, Discrete Cosine Transforms (DCT), inverse DCT, quantization, and inverse quantization.

The Vibratto-II DVD processor supports all popular pick-up units, industry standard I²S audio data input and output, EPROM and DRAM access. It also supports both letterbox and pan-and-scan displays, sub-picture overlay, and On-Screen Display (OSD).

The Vibratto-II's Unified Memory Architecture enables the lowest possible system memory cost by consolidating multiple memory subsystems into a single unit.

In addition, the Vibratto-II DVD solution offers support for Karaoke CD+G, DVD-Audio, HDCD, CD-DA, MP3, and WMA.

The ES6230 DVD processor is available in 208-pin Low-profile Quad Flat Pack (LQFP) package.

FEATURES

- Single-chip DVD processor incorporating all front-end and back-end functions.
- Unified memory architecture.
- Proven focusing, sledding, tracking, and CLV/CAV spindle servo control.
- Proven ECC, EFM/EFM+ demodulation, and EDC circuit.
- Built-in ADCs and DACs for servo control signals.
- Direct interface to the ES6603 servo AFE chip.
- Integrated NTSC/PAL encoder with pixel-adaptive de-interlacer and three 10-bit 54 MHz video DACs.
- DVD-Video, DVD-VR, VCD 1.1 and 2.0, and SVCD.
- Full DVD-Audio support including MLP and LPCM decode, CPPM decryption, and watermark detection.
- Media playback with CD-ROM, CD-R/RW, DVD-R/RW, and DVD+R/RW.
- Up to 7.1 channel audio outputs.
- Direct interface of 16-bit DRAM up to 128-Mb capacity.
- Direct interface for up to 4 banks of 8-bit EPROM or Flash EPROM for up to 4 MB per bank.
- Macrovision 7.1 for NTSC/PAL interlaced video.
- Macrovision AGC 1.03-compliant for 480p progressive scan video.
- Simultaneous composite, S-video and YUV outputs.
- CCIR 656/601 YUV 4:2:2 output.
- OSD controller supports 256 colors in 8 degrees of transparency.
- Subpicture Unit (SPU) decoder supports karaoke lyric, subtitles, and EIA-608 compliant Line 21 Captioning.
- SmartLogo™ for custom JPEG wallpaper.
- JPEG digital photo support (Kodak Picture CD™ and Fujifilm FujiColor CD™).
- ESS Music Slideshow™.
- Windows™ Media Audio (WMA).
- Dolby Digital (AC-3), Dolby Pro Logic™, and Pro Logic II.
- DTS surround.
- S/PDIF digital audio input and output.
- MPEG AAC and Multichannel.
- SRS TruSurround®.
- Professional karaoke with full scoring scheme.
- Slave mode operation for control by host processor.
- Extended temperature range -20° C to 70° C ambient for automotive applications.
- Lead-free leads using 98%-Sn/2%-Cu or 98%-Sn/2%-Bi.



ES6230 PINOUT DIAGRAM

The device pinout for the ES6230 is shown in Figure 1..

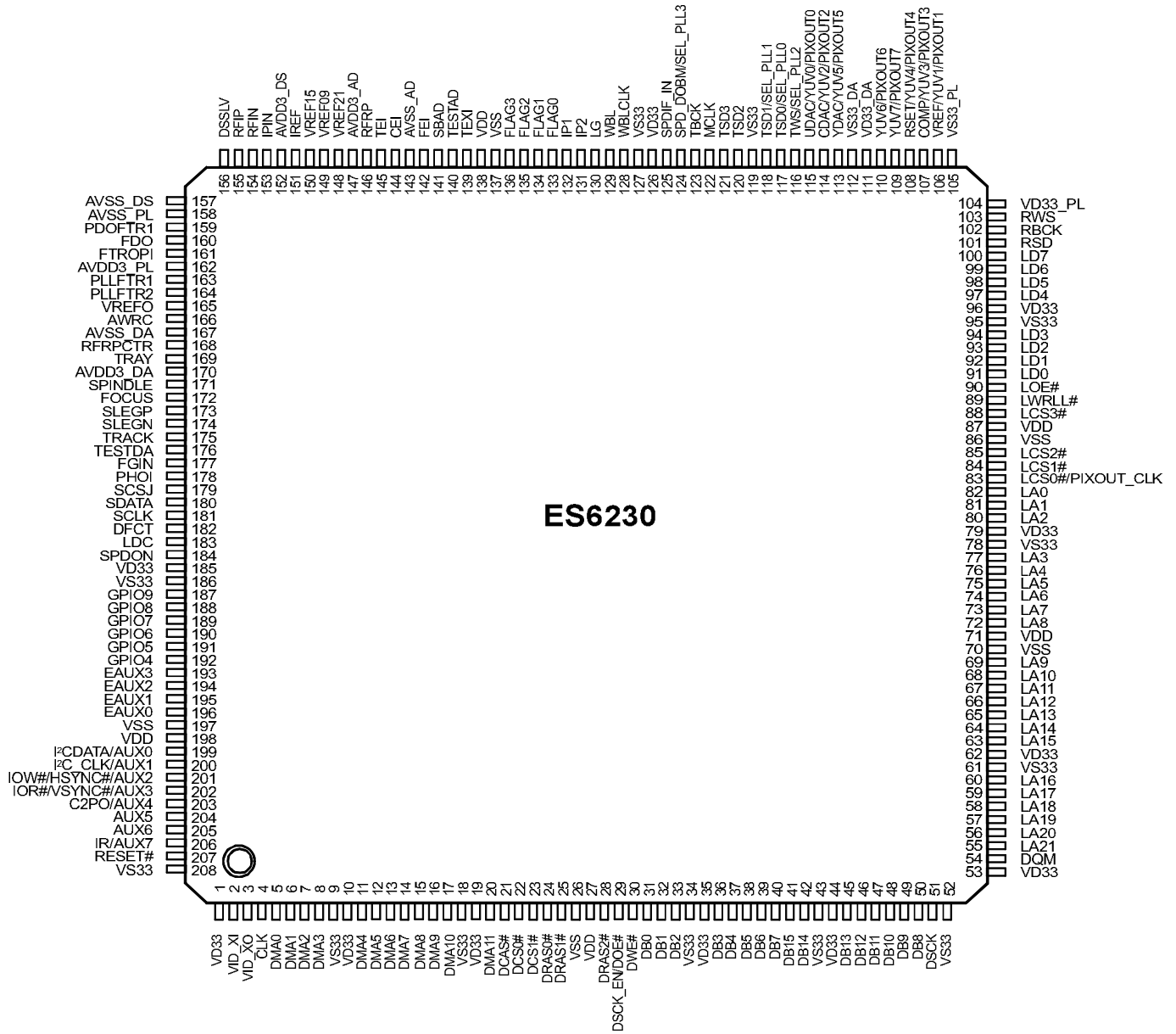

Figure 1 ES6230 Device Pinout

SYSTEM BLOCK DIAGRAM

A sample system block diagram for the ES6230 Vibratto-II DVD player board design is shown in Figure 2.

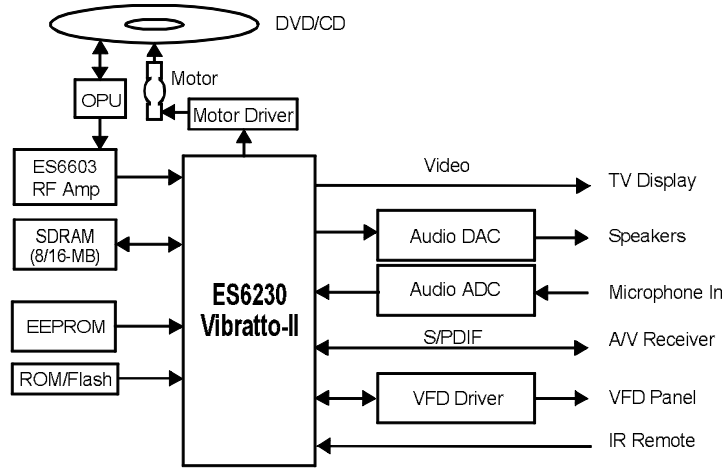

Figure 2 ES6230 Vibratto-II System Block Diagram

FUNCTIONAL DESCRIPTION

Figure 3 shows the internal block diagram for the ES6230 Vibratto-II DVD processor.

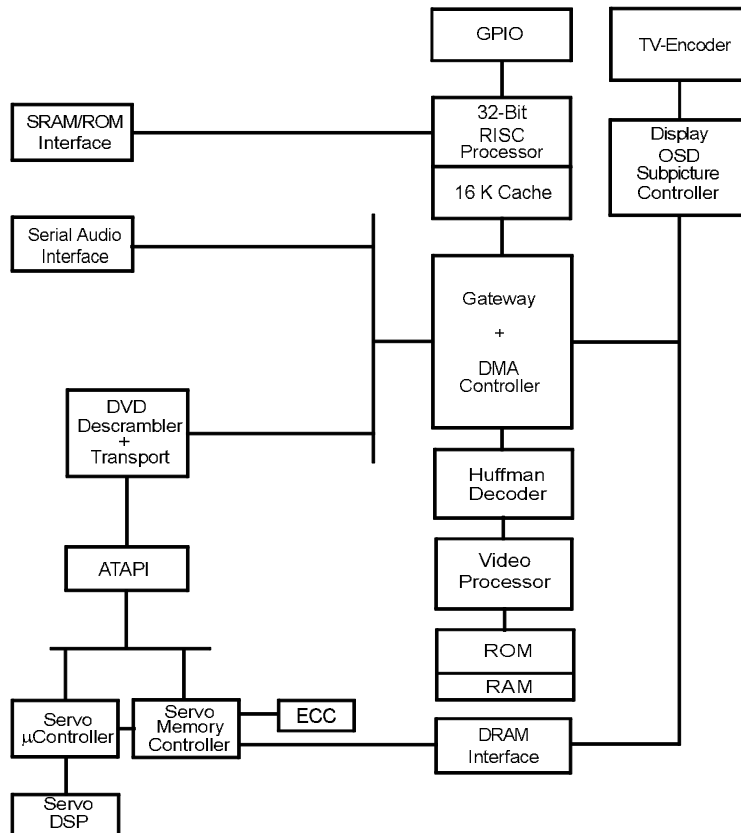

Figure 3 ES6230 Vibratto-II Block Diagram

ORDERING INFORMATION

Part Number	Description	Package
ES6230SF	Vibratto-II Automotive DVD, Servo, Progressive scan, DVD-Audio, and TV encoder	208-pin LQFP
ES6603SF	DVD Servo AFE for Vibratto-II	64-pin LQFP

The letter SF at the end of the part number identifies the package type LQFP with lead-free leads. When ordering ES6603SF for use with ES6230SF, specify "extended temperature range" for the ES6603SF.

Other Vibratto-II DVD processors

Part Number	Description	Package
ES6629F	Vibratto-II DVD, Servo Control, Progressive scan, and TV encoder	208-pin PQFP
ES6629FD	Vibratto-II DVD, Servo Control, Progressive scan, DTS surround, and TV encoder	208-pin PQFP
ES6688FA	Vibratto-II DVD, Servo Control, Progressive scan, MPEG-4, DVD-Audio, and TV encoder	208-pin PQFP
ES6688FAD	Vibratto-II DVD, Servo Control, Progressive scan, MPEG-4, DVD-Audio, DTS surround, and TV encoder	208-pin PQFP
ES6698F	Vibratto-II DVD, Servo Control, Progressive scan, DivX (certified), DVD-Audio, and TV encoder	208-pin PQFP
ES6698FD	Vibratto-II DVD, Servo Control, Progressive scan, DivX (certified), DVD-Audio, DTS surround, and TV encoder	208-pin PQFP

The letter F at the end of the part number identifies the package type PQFP.



ESS Technology, Inc.
48401 Fremont Blvd.
Fremont, CA 94538
Tel: (510) 492-1088
Fax: (510) 492-1898

No part of this publication may be reproduced, stored in a retrieval system, transmitted, or translated in any form or by any means, electronic, mechanical, manual, optical, or otherwise, without the prior written permission of ESS Technology, Inc.

ESS Technology, Inc. makes no representations or warranties regarding the content of this document.

All specifications are subject to change without prior notice.

ESS Technology, Inc. assumes no responsibility for any errors contained herein.

U.S. patents pending.

MPEG is the Moving Picture Experts Group of the ISO/IEC. References to MPEG in this document refer to the ISO/IEC JTC1 SC29 committee draft ISO 11172 dated January 9, 1992.

Vibratto, SmartBright, SmartLogo, SmartColor, and Music Slideshow are trademarks of ESS Technology, Inc.

Dolby is a trademark of Dolby Laboratories, Inc.

Trusurround, Trusurround XT, SRS, and (o) symbol are trademarks of SRS Labs., Inc.

All other trademarks are trademarks of their respective companies and are used for identification purposes only.