



12MHz 20V/ μ s G=1,2,4,8 Programmable Gain μ COSTM Instrumentation Amplifier

Preliminary Technical Data

AD8251

FEATURES

Easy to Use

Programmable Gains: 1, 2, 4, 8

Digital or Pin Programmable Gain Setting

Temp Range -40°C to 85°C

EXCELLENT DC PERFORMANCE

High CMRR 98dB G=8

Low Gain Drift: 10ppm/°C

Low Offset Drift: 1 μ V/°C

Low Offset: 75 μ V G=8

EXCELLENT AC PERFORMANCE

Fast Settle Time: 0.5 μ s to 0.01%

High Slew Rate: 20V/ μ s

High CMRR over Frequency: 80dB to 50kHz

Low Noise: 13nV \sqrt Hz, G=8

Low Power: 3.5 mA (typ)

Supply: \pm 5V to \pm 12V

Applications

Data Acquisition

Bio-Medical Analysis

Test and Measurement

High Performance System Monitoring

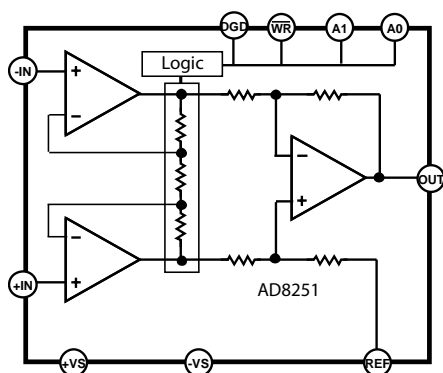

Figure 1. Functional Block Diagram

GENERAL DESCRIPTION

The AD8251 is a digitally gain programmable instrumentation amplifier that has high $G\Omega$ input impedance and low distortion making it suitable for sensor interfacing and driving high sample rate analog to digital converters. It has high bandwidth of 12MHz, low distortion and settle time of 0.5 μ s to 0.01%. Offset drift and gain drift are limited to 1 μ V/°C and 10ppm/°C respectively. In addition to its wide input common-voltage range, it boasts a high common-mode rejection of 80dB at G=1 from DC to 50kHz. The combination of precision DC performance coupled with high speed capabilities make the AD8251 an excellent candidate for data acquisition and medical applications. Furthermore, this monolithic solution simplifies design, manufacturing and boosts performance of instrumentation by maintaining tight match of internal resistors and amplifiers.

The AD8251's user interface comprises of a parallel port that allows users to set the gain in one of three different ways. A two bit word sent to A1 and A2, via a bus may be latched using the \overline{WR} input. An alternative is to set the gain within 1 μ s by using the gain port in transparent mode where the state of A0 and A1 directly set the gain. The last method is to strap A1 and A2 to a high or low voltage potential, permanently setting the gain.

The AD8251 is available in a 10 pin MSOP package and specified over -40°C to 85°C, making it an excellent solution for applications where size and packing density are important considerations.

Rev.PrB

Information furnished by Analog Devices is believed to be accurate and reliable. However, no responsibility is assumed by Analog Devices for its use, nor for any infringements of patents or other rights of third parties that may result from its use. Specifications subject to change without notice. No license is granted by implication or otherwise under any patent or patent rights of Analog Devices. Trademarks and registered trademarks are the property of their respective companies.

One Technology Way, P.O. Box 9106, Norwood, MA 02062-9106, U.S.A.
Tel: 781.329.4700 www.analog.com
Fax: 781.326.8703 © 2006 Analog Devices, Inc. All rights reserved.

TABLE OF CONTENTS

AD8251—Specifications.....	3	Transparent Gain Setting Mode:	5
Timing Diagram	5	Write Enable Gain Setting Mode:.....	5
Absolute Maximum Ratings.....	5	Outline Dimensions	5
Pin Configurations And Functional Descriptions	5	ESD Caution.....	5

Preliminary Revision : B

REVISION HISTORY

AD8251—SPECIFICATIONS

Table 1. $V_S = \pm 12\text{ V}$, $V_{REF} = 0\text{ V}$ (@ $T_A = 25^\circ\text{C}$, $G = +1$, $R_L = 2\text{ k}\Omega$, unless otherwise noted.)

Parameter	Conditions	AD8251ARM			Unit
		Min	Typ	Max	
COMMON-MODE REJECTION RATIO (CMRR)					
CMRR to 60 Hz with 1 k Ω Source Imbalance	$V_{CM} = -10\text{ V to }+10\text{ V}$ $G = 1$ $G = 2$ $G = 4$ $G = 8$		80 86 92 98		dB dB dB dB
CMRR to 50kHz	$V_{CM} = -10\text{ V to }+10\text{ V}$ $G = 1$ $G = 2$ $G = 4$ $G = 8$		80		dB dB dB dB
NOISE					
Voltage Noise, 1kHz	$G=1$ $G=2$ $G=4$ $G=8$		32 20 15 13		nV/ $\sqrt{\text{Hz}}$ nV/ $\sqrt{\text{Hz}}$ nV/ $\sqrt{\text{Hz}}$ nV/ $\sqrt{\text{Hz}}$
RTI, 0.1 Hz to 10 Hz	$G=1$ $G=2$ $G=4$ $G=8$				$\mu\text{V p-p}$ $\mu\text{V p-p}$ $\mu\text{V p-p}$ $\mu\text{V p-p}$
Current Noise	$f = 1\text{ kHz}$				$\mu\text{V p-p}$ fA/ $\sqrt{\text{Hz}}$
VOLTAGE OFFSET					
Offset, V_{OS}	$G=1, V_S = \pm 5\text{ V to } \pm 12\text{ V}$		250		μV
Over Temperature	$T = -40^\circ\text{C to }+85^\circ\text{C}$				μV
Average TC	$T = -40^\circ\text{C to }+85^\circ\text{C}$				$\mu\text{V}/^\circ\text{C}$
Offset, V_{OS}	$G=2, V_S = \pm 5\text{ V to } \pm 12\text{ V}$		150		μV
Over Temperature	$T = -40^\circ\text{C to }+85^\circ\text{C}$				μV
Average TC	$T = -40^\circ\text{C to }+85^\circ\text{C}$				$\mu\text{V}/^\circ\text{C}$
Offset, V_{OS}	$G=4, V_S = \pm 5\text{ V to } \pm 12\text{ V}$		100		μV
Over Temperature	$T = -40^\circ\text{C to }+85^\circ\text{C}$				μV
Average TC	$T = -40^\circ\text{C to }+85^\circ\text{C}$				$\mu\text{V}/^\circ\text{C}$
Offset, V_{OS}	$G=8, V_S = \pm 5\text{ V to } \pm 12\text{ V}$		75		μV
Over Temperature	$T = -40^\circ\text{C to }+85^\circ\text{C}$				μV
Average TC	$T = -40^\circ\text{C to }+85^\circ\text{C}$				$\mu\text{V}/^\circ\text{C}$
Offset Referred to the Input vs. Supply (PSR)	$V_S = \pm 8\text{ V to } \pm 12\text{ V}$				
$G = 1$			115		dB
$G = 2$			110		dB
$G = 4$			110		dB
$G = 8$		96	110		dB
INPUT CURRENT					
Input Bias Current			10	25	nA
Over Temperature	$T = -40^\circ\text{C to }+85^\circ\text{C}$			35	nA

AD8251

Preliminary Technical Data

Parameter	Conditions	AD8251ARM			Unit
		Min	Typ	Max	
Average TC					pA/°C
Input Offset Current			5	10	nA
Over Temperature	T = -40°C to +85°C				nA
Average TC			1.5		pA/°C
DYNAMIC RESPONSE					
Small Signal -3dB Bandwidth					
	G=1		17		MHz
	G=2		15		MHz
	G=4		12		MHz
	G=8		5		MHz
Settling Time 0.01%	10 V Step				
	G=1		0.5		μS
	G=2				μS
	G=4				μS
	G=8				μS
Settling Time 0.001%	10 V Step				
	G=1		1.5		μS
	G=2				μS
	G=4				μS
	G=8				μS
Slew Rate					
	G=1	20		35	V/μS
	G=2	30		35	V/μS
	G=4	30		35	V/μS
	G=8	30		35	V/μS
Total Harmonic Distortion + Noise					
	RL = 100kOhms, G=1				%
	RL = 2kOhms, G=1				%
GAIN					
Gain Range: 1, 2, 4, 8		1		10	V/V
Gain Error	V _{OUT} = ±10 V				
	G=1		0.05		%
	G=2				
	G=4				
	G=8				
Gain Nonlinearity	V _{OUT} = -10 V to +10 V				
	G=1, R _L = 10 kΩ		4		ppm
	G=2, R _L = 10 kΩ		4		ppm
	G=4, R _L = 10 kΩ		4		ppm
	G=8, R _L = 10 kΩ		4		ppm
Gain Nonlinearity	G=1-8, R _L = 2 kΩ		4		ppm
Gain vs. Temperature	All Gains			10	ppm/°C
INPUT					
Input Impedance					
Differential			1 2		GΩ pF
Common Mode			1 2		GΩ pF
Input Operating Voltage Range	V _S = ±5 V to ±12 V	-V _S + 1		+V _S	V
Over Temperature	T = -40°C to +85°C			1.5	V

Preliminary Technical Data

AD8251

Parameter	Conditions	AD8251ARM			Unit
		Min	Typ	Max	
OUTPUT	$R_L = 10\text{ k}\Omega$				
Output Swing	$V_S = \pm 5\text{ V to } \pm 12\text{ V}$	$-V_S + 1.5$		$+V_S - 1.5$	V
Over Temperature	$T = -40^\circ\text{C to } +85^\circ\text{C}$				V
Short Circuit Current			20		mA
REFERENCE INPUT					
R_{IN}			20		$\text{k}\Omega$
I_{IN}	$V_{IN+}, V_{IN-}, V_{REF} = 0$				μA
Voltage Range		$-V_S$		$+V_S$	V
Gain to Output					V/V
Digital Logic Inputs					V
Digital Ground Voltage, DGND	Referenced to DGND		1		V
Digital Input Voltage Low	Referenced to DGND		4		V
Digital Input Voltage High					V
Digital Input Leakage Current					μA
Gain Switching Time					ns
T_{SU}					ns
T_{HD}					ns
T_{WR_LO}					ns
T_{WR_HI}					ns
POWER SUPPLY					
Operating Range ³		± 5		± 12	V
Quiescent Current			3.5		mA
Over Temperature	$T = -40^\circ\text{C to } +85^\circ\text{C}$				mA
TEMPERATURE RANGE					
Specified Performance		-40		$+85$	$^\circ\text{C}$

TIMING DIAGRAM

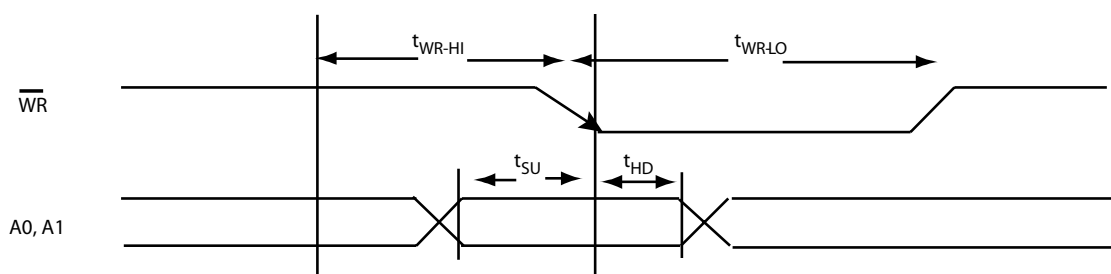

Figure 2. Timing Diagram

ABSOLUTE MAXIMUM RATINGS

Table 2. AD8251 Absolute Maximum Ratings

Parameter	Rating
Supply Voltage	+/-14V
Power Dissipation	See Figure 2
Output Short Circuit Current	
Common-Mode Input Voltage	-Vs - 0.5 V to +Vs + 0.5 V
Differential Input Voltage	V
Storage Temperature	-65°C to +125°C
Operating Temperature Range	-40°C to +85°C
Lead Temperature Range (Soldering 10 sec)	°C
Junction Temperature	°C
Θ _{JA} (4 layer JEDEC Standard)	°C/W

Board)	
Package Glass Transition Temperature	°C
ESD (Human Body Model)	kV
ESD (Charge Device Model)	kV
ESD (Machine Model)	kV

Stresses above those listed under Absolute Maximum Ratings may cause permanent damage to the device. This is a stress rating only and functional operation of the device at these or any other conditions above those indicated in the operational section of this specification is not implied. Exposure to absolute maximum rating conditions for extended periods may affect device reliability.

PIN CONFIGURATIONS AND FUNCTIONAL DESCRIPTIONS

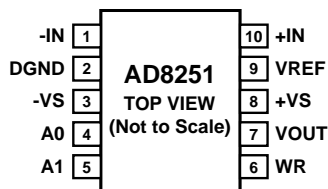

NC = NO CONNECT

Figure 3. 10-Lead MSOP

**Table 3. Pin Function Descriptions—
10-Lead MSOP(ARM PACKAGE)**

Pin No.	Name	Description
1	-IN	Inverting Input Terminal (True differential input)
2	DGND	Digital Ground.
3	-Vs	Negative Supply Terminal
4	A0	Gain Setting Pin (LSB)
5	A1	Gain Setting Pin (MSB)
6	$\overline{\text{WR}}$	Write Enable
7	VOUT	Output Terminal
8	+Vs	Positive Supply Terminal
9	VREF	Reference Voltage Terminal (drive this pin with a low impedance voltage source to level shift the output signal)
10	+IN	Non-inverting Input Terminal (True differential input)

GAIN SETTING

The AD8251's gains are set digitally. The A0 and A1 pins must be set either HIGH or LOW with respect to digital ground, DGND. The $\overline{\text{WR}}$ pin is a tri-state switch. It may be set to one of three levels, HIGH, LOW or to $-V_s$. A HIGH signal is typically greater than 4V but less than 6V and a LOW signal is typically less than 1V but higher than DGND, 0V. Gains can be programmed using the following methods:

TRANSPARENT GAIN SETTING MODE:

In this mode, the gain is set by toggling A0 and A1 to HIGH or LOW. To enable transparent mode, tie $\overline{\text{WR}}$ to $-V_s$. This configures the AD8251 to change gains when A0 and A1 are set according to Table 4.

Table 4. . Transparent Mode Gain Settings

G	$\overline{\text{WR}}$	A1	A0
1	$-V_s$	LO	LO
2	$-V_s$	LO	HI
4	$-V_s$	HI	LO
8	$-V_s$	HI	HI

WRITE ENABLE GAIN SETTING MODE:

In this mode, the gains are changed only during the negative edge of the $\overline{\text{WR}}$ strobe. So for instance, the gain is determined by the two bit value held on A0 and A1 at the time the $\overline{\text{WR}}$ strobe transitions from HIGH to LOW.

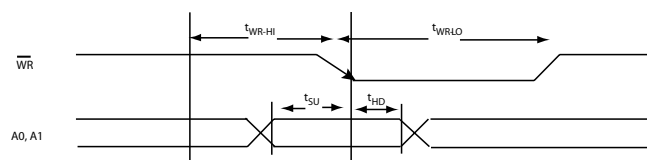
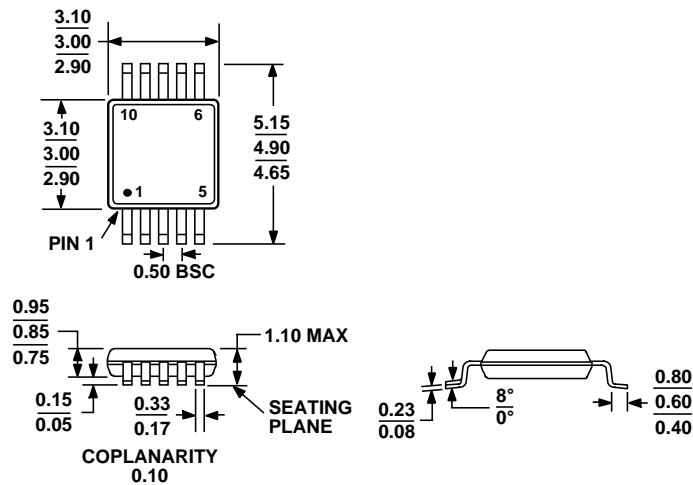

Table 5. : Write Enable Mode Gain Settings

Gain (changes to)	$\overline{\text{WR}}$	A1	A0
1	HI -> LO	LO	LO
2	HI -> LO	LO	HI
4	HI -> LO	HI	LO
8	HI -> LO	HI	HI
No Change	LO->LO	X	X
No Change	LO->HI	X	X
No Change	HI-> HI	X	X

X = don't care

OUTLINE DIMENSIONS



COMPLIANT TO JEDEC STANDARDS MO-187-BA

Figure 4. 10 Lead MSOP (RM) – Dimensions shown in millimeters

ESD CAUTION

ESD (electrostatic discharge) sensitive device. Electrostatic charges as high as 4000 V readily accumulate on the human body and test equipment and can discharge without detection. Although this product features proprietary ESD protection circuitry, permanent damage may occur on devices subjected to high energy electrostatic discharges. Therefore, proper ESD precautions are recommended to avoid performance degradation or loss of functionality.



Table 6. Ordering Guide

AD00000 Products	Temperature Package	Package Description	Package Option	Branding
AD8251ARZ	-40°C to +85°C	10-Lead MSOP	RM-10	
AD8251ARZ-RL	-40°C to +85°C	10-Lead MSOP	RM-10	
AD8251ARZ-R7	-40°C to +85°C	10-Lead MSOP	RM-10	
AD8251-EVAL		Evaluation Board		