



SPEC. NO	MSA99-TBD
ISSUED DATE	8. 24. 99

CUSTOMER	:	
M O D E L	:	OGM-128GS48-2-A4000
DESCRIPTION	:	LCD MODULE

THIS SPECIFICATION IS APPLIED FOR LCD MODULE DELIVERED TO YOUR COMPANY BY ORION DISPLAY TECHNOLOGY CO., LTD

◆ CUSTOMER APPROVAL

	CHECKED	CHECKED	APPROVAL
APPROVAL			
REMARK			

◆ SUPPLIER APPROVAL

PREPARED	CHECKED		APPROVAL

ADDRESS : ORION DISPLAY TECHNOLOGY CO., LTD
1631-1, SEOCHO-DONG, SEOCHO-KU, SEOUL, KOREA
(TEL) 82-2-598-0350 (FAX) 82-2-598-0360

	LCD MODULE SPECIFICATION FOR APPROVAL	ISSUED DATE	1999. 8. 24
		REV. NO.	1
	OGM-128GS48-2-A4000	PAGE	3 OF 12

CONTENTS

1. FEATURES -----	4
2. MECHANICAL SPECIFICATION -----	4
3. ABSOLUTE MAXIMUM RATINGS -----	5
4. ELECTRICAL CHARACTERISTICS -----	5
5. ELECTRO-OPTICAL CHARACTERISTICS -----	6
6. QUALITY SPECIFICATION -----	7
7. RELIABILITY -----	10
8. PIN CONNECTIONS -----	10
9. PRECAUTION FOR USING -----	11
10. EXTERNAL DIMENSION-----	12

NOTE: When using this specification, the reader should keep the followings in mind.

1. This specification may, wholly or partially, be subjected to change without notice.
2. Information contained herein is proprietary information of ORION DISPLAY TECHNOLOGY CO.,LTD. The dissemination use or duplication for any purpose other than for which the information is provided is prohibited by ORION DISPLAY TECHNOLOGY CO., LTD except by express permission.

	LCD MODULE SPECIFICATION FOR APPROVAL	ISSUED DATE	1999. 8. 24
	OGM-128GS48-2-A4000	REV. NO.	1
		PAGE	4 OF 12

1. FEATURES

- 1) Number of dots ----- 480 X 128 dots
- 2) Display mode ----- STN-YELLOW
- 3) Display type ----- Positive, Transflective
- 4) Viewing direction ----- 6 o'clock
- 5) Operating temperature ----- Indoor
- 6) Drving voltage ----- Double power
- 7) Driving method ----- 1/128 duty, 1/12.3 bias
- 8) Type ----- COB (Chip On Board)
- 9) Number of data line ----- 1-bit serial (2 lines)
- 10) Backlighting ----- EL backlighter (Emitting color : White)

2. MECHANICAL DATA

ITEM		WIDTH	HEIGHT	THICKNESS	UNIT
Module size		270.0	110.0	11.5	mm
Viewing area		242.0	69.0	-	mm
Dot	Size	0.43	0.43	-	mm
	Pitch	0.48	0.48	-	mm
Diameter of mounting hole		6-3.5			mm
Weight		About 320			g

	LCD MODULE SPECIFICATION FOR APPROVAL		ISSUED DATE	1999. 8. 24
			REV. NO.	1
	OGM-128GS48-2-A4000		PAGE	5 OF 12

3. ABSOLUTE MAXIMUM RATINGS

ITEM	SYMBOL	CONDITION	STANDARD VALUE		UNIT
			MIN.	MAX.	
Power supply for logic	$V_{DD}-V_{SS}$	$T_a=25^{\circ}\text{C}$	0	7.0	V
Power supply for LCD	$V_{DD}-V_L$	$T_a=25^{\circ}\text{C}$	0	30	V
Input voltage	V_{IN}	$T_a=25^{\circ}\text{C}$	V_{SS}	V_{DD}	V
Operating temperature	T_{OP}	-	0	50	$^{\circ}\text{C}$
Storage temperature	T_{STG}	-	-20	70	$^{\circ}\text{C}$

4. ELECTRICAL CHARACTERISTICS

ITEM	SYMBOL	CONDITION	STANDARD VALUE			UNIT
			MIN.	TYP.	MAX.	
Power supply for logic	V_{DD}	$T_a = 25^{\circ}\text{C}$	4.5	5	5.5	V
Input high voltage	V_{IH}	-	$V_{DD}-0.8$	-	V_{DD}	V
Input low voltage	V_{IL}	-	V_{SS}	-	0.8	V
Output high voltage	V_{OH}	$I_{OH} = -0.205 \text{ mA}$	$V_{DD}-0.3$	-	V_{DD}	V
Output low voltage	V_{OL}	$I_{OL} = 1.2 \text{ mA}$	V_{SS}	-	0.3	V
Power supply current	I_{DD}	$V_{DD}=5.0\text{V}, V_{LCD}=7.8\text{V}$	-	5.0	10.0	mA
Power supply for LCD (Note 1) = V_{LCD}	$V_{DD}-V_L$	$T_a = 0^{\circ}\text{C}$	-	-	-	V
		$T_a = 25^{\circ}\text{C}$	-	12.4	-	V
		$T_a = 50^{\circ}\text{C}$	-	-	-	V

Note 1 : Power supply for LCD is available with R_L in accordance with contrast.

	LCD MODULE SPECIFICATION FOR APPROVAL	ISSUED DATE	1999. 8. 24
	OGM-128GS48-2-A4000	REV. NO.	1
		PAGE	6 OF 12

5. ELECTRO-OPTICAL CHARACTERISTICS (STN)

(Ta = 25 °C)

ITEM	SYMBOL	MIN.	TYP.	MAX.	UNIT	NOTE
Contrast ratio	K	2.0	4.0	-	-	1
Response time (rise)	T_r	-	150	250	ms	2
Response time (fall)	T_f	-	150	250	ms	2
Viewing angle	ϕ	-20 ~ +50			deg.	3,4
	θ	-40 ~ +40				

NOTE1. Definition of contrast K

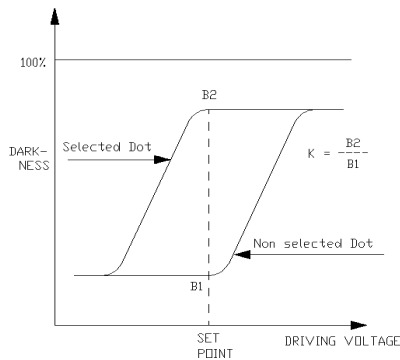

NOTE2. Definition of optical response

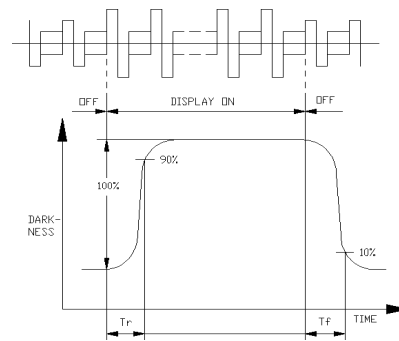

NOTE3. Definition of angle θ and ϕ

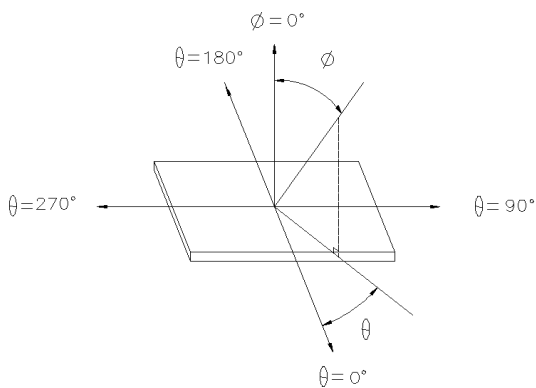

NOTE4. Definition of viewing angle ϕ_1 and ϕ_2

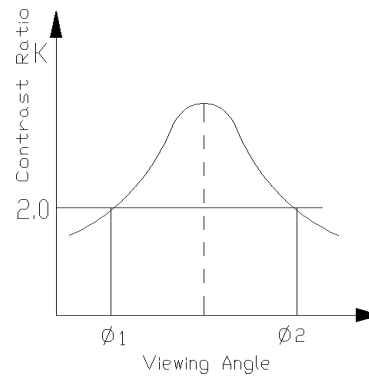

	LCD MODULE SPECIFICATION FOR APPROVAL	ISSUED DATE	1999. 8. 24
		REV. NO.	1
	OGM-128GS48-2-A4000	PAGE	7 OF 12

6. QUALITY SPECIFICATION

6.1 Acceptable Quality Level

INSPECTION ITEM	SAMPLING PROCEDURES	A.Q.L
MAJOR	MIL-STD-105E Inspection Level II Normal Inspection Single sample inspection	1.0
MINOR	MIL-STD-105E Inspection Level II Normal Inspection Single sample inspection	2.5

Major defect :

A major defect is a defect that could result in failure or materially reduce that the usability of the unit of product for its intended purpose.

Minor defect :

A minor defect is one that does not materially reduce the usability of the product for its intended purpose or is a departure from established standards giving no significant bearing on the effective use or operation of the unit.

6.2 Inspection Conditions

6.2.1 The environmental conditions for inspection shall be as follows

-Room Temperature : $25 \pm 3^{\circ}\text{C}$

-Humidity Temperature : $65 \pm 20\% \text{RH}$

6.2.2 The external visual inspection

-The inspection shall be performed by using 40Watts fluorescent lamp for illumination and the distance between LCD and eyes of the inspector shall be 30cm or more.

6.3 Definition of the Area

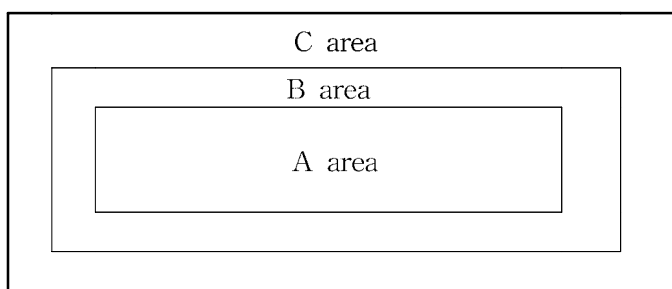

A area: Active Area

B area: Viewing Area

C area: Out of Viewing Area

	LCD MODULE SPECIFICATION FOR APPROVAL	ISSUED DATE	1999. 8. 24
		REV. NO.	1
	OGM-128GS48-2-A4000	PAGE	8 OF 12

6.4 Inspection Standards

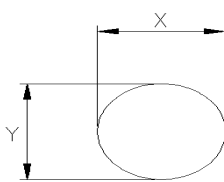
Class of defects	Inspection Item	Criteria of defects	Remarks	
MAJOR	Display on inspection	1) No Display 2) Abnormal Operation 3) Short Circuit 4) Pattern Open 5) Off Viewing angle		
	Missing	Component missing		
MINOR	Spot/Dent	Size	Defect size	Acceptable Number
		A Size	$\phi < 0.15$ mm	Ignore
			$0.15 < \phi \leq 0.25$ mm	3
			$\phi > 0.25$ mm	0
		B Size	$\phi < 0.15$ mm	Ignore
			$0.15 < \phi \leq 0.25$ mm	4
			$\phi > 0.25$ mm	0
			Cell Size (Viewing Area Criteria) ※ A size $< 2500\text{mm}^2$ Spot size = $(X+Y)/2$ B size $\geq 2500\text{mm}^2$	
				
	Scratch	POSITIVE		NEGATIVE
Width X Length		Acceptable Number	Width X Length	Acceptable Number
0.1 X 1.5 mm		3	0.1 X 1.5 mm	3
0.08 X 3.0 mm		2	0.08 X 3.0 mm	2
0.05 X 5.0 mm		1	0.05 X 5.0 mm	1
※ Scratches should be separated more than 10mm each other				
Bubble	1) Round bubble should be treated as spot(positive) 2) Line bubble should be treated as scratch(positive)			

	LCD MODULE SPECIFICATION FOR APPROVAL	ISSUED DATE	1999. 8. 24
	OGM-128GS48-2-A4000	REV. NO.	1
		PAGE	9 OF 12

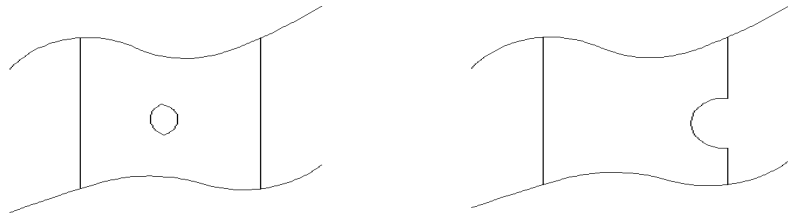
Class of defects	Inspection Item	Criteria of defects	Remarks
MINOR	Pattern Misalignment	Voids in segment 	
	Stain	Stains which cannot be removed even when wiped slightly with a soft cloth.	
	Rainbow	More than 2 colors are noticeable in the viewing direction.	
MINOR	PCB damage	Damage on gold or copper foil	
	Parts alignment	1) IC lead width is more than 50% beyond land pattern 2) Chip component is off center and more than 50% of the leads is off the pad out line.	
	Conductive foreignmatter (solderball, soldersplash)	Conductive foreign matter is not allowed	
	Bezel claw	Bezel claw missing or not bent	

	LCD MODULE SPECIFICATION FOR APPROVAL	ISSUED DATE	1999. 8. 24
		REV. NO.	1
	OGM-128GS48-2-A4000	PAGE	10 OF 12

7. RELIABILITY

ITEM	TEST	CRITERION
High temp.	70°C / 200 Hrs	* Total current consumption should be below double of initial value
Low temp.	-20°C / 200 Hrs	
High humidity	40°C X 90%RH / 200 Hrs	
Thermal shock	-20°C → 25°C → 70°C → 25°C / 5 Cycles (20min) (5min) (30min) (5min)	* Contrast ratio should be within initial value ±50%
Vibration	1.Operating time : Thirty minutes exposure for each direction(x,y,z) 2.Sweep frequency (1min) : 10Hz →55Hz →10Hz 3.Amplitude : 0.75mm	* No defect in cosmetic and operational function is allowable

* Remarks : Samples subjected to the tests shall be “ Not operating ” condition .

8. PIN CONNECTIONS

PIN NO.	SYMBOL	LEVEL	FUNCTION
1	D1	H/L	Serial row data (left half)
2	D2	H/L	Serial row data (right half)
3	FLM	H/L	Signal of display cycle
4	DF	-	Not used (no connection)
5	LO	H->L	Latch of serial data
6	CP	H->L	Shift of serial data
7	V _{DD}	-	Power supply for logic circuit
8	V _{SS}	-	Ground
9	V _{EE}	-	Power supply for LC driving
10	V _L	-	Power supply for LCD operating

* In case of 4 bits instruction, data is transferred by twice using only 4 buses of D4 to D7, and D0 to D3 are not used, first operation is higher order 4 bits and second is lower 4bits of 8 bits, but in case of 8 bits instruction data is transferred by data bus of D0 to D7.

	LCD MODULE SPECIFICATION FOR APPROVAL	ISSUED DATE	1999. 8. 24
		REV. NO.	1
	OGM-128GS48-2-A4000	PAGE	11 OF 12

9. PRECAUTION FOR USING

16.1 HANDLING

- 1) Refrain from storing mechanical shock and from applying any force to LCD MODULE.
It may cause mis_operation or damage of LCD.
- 2) Do not touch, press or rub the display panel with a hard, stiff tool or object as the polarizers in the panel are easily scratched.
- 3) If LCD is broken and liquid crystal material flow out, ingestion, inhalation, or contact with skin should be avoided. If liquid crystal material contact with skin, wash immediately with alcohol and rinse thoroughly with water.
- 4) Never use organic solvents to clear the display panel as these solvent may adversely affect the polarizer. To clean the display panel dampen a bit of absorbent cotton with petroleum benzene and gently wipe the panel, or contaminations by using a scotch tape.
- 5) Refrain from discharge of high electro-static voltage, it will damage C-MOS LSI in the MODULE.
- 6) Do not leave the MODULE in high temperature, especially in high humidity for a long time. It is recommended to store the MODULE where the temperature is in the range of 0°C to 35°C and the humidity is lower than 70%.
- 7) Store the MODULE without exposure to direct sunlight or fluorescent lamp.
- 8) Ultra violet cut filter is necessary for outdoor operation.
- 9) Avoid condensation of water, it may cause mis-operation or disconnection of electrode.

16.2 OPERATION

- 1) Never connect or disconnect the LCD MODULE from the main system while power is being supplied.
- 2) When supplying the M signal from the external unit to a GRAPHIC MODULE, set the duty to $50\% \pm 1\%$.
If the duty deviates too greatly from the value, a DC voltage will be applied to the liquid crystal, which could induce an electrochemical reaction and reduce the life of the MODULE.
- 3) Do not exceed the maximum rating values under the worst conditions taking account of the supply voltage variation, input voltage variation, and environmental temperature, etc. Otherwise LCD module may be damaged.

	LCD MODULE SPECIFICATION FOR APPROVAL OGM-128GS48-2-A4000	ISSUED DATE	1999. 8. 24
		REV. NO.	1
		PAGE	12 OF 12

10. EXTERNAL DIMENSION

