

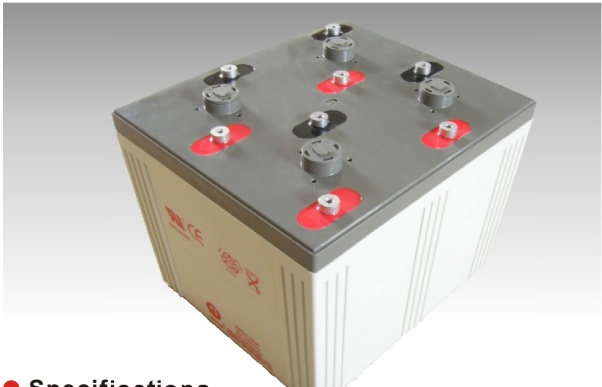

SW215000E(2V1500AH)



● Specifications

Nominal Voltage		2 V
Rated capacity (10 hour rate)		1500 Ah
Dimensions	Total Height	369 mm (14.5 inches)
	Height	342 mm (13.5 inches)
	Length	401 mm (15.8 inches)
	Width	351 mm (13.8 inches)
Weight Approx		100Kg(220lbs)

● Characteristics

Capacity 25°C(77°F)	10 hour rate(150 A)	1500 AH
	5 hour rate(240 A)	1200 AH
	1 hour rate(825 A)	825AH
	1.5 hour discharge to 1.75 V	600 A
Internal Resistance	Full charged Battery at 25°C(77°F)	0.9 mΩ
Capacity affected by Temperature (10hour rate)	40°C(104°F)	102%
	25°C(77°F)	100%
	0°C(32°F)	85%
	-15°C(5°F)	65%
Self-Discharge at 25°C(77°F)	Capacity after 3 month storage	91%
	Capacity after 6 month storage	82%
	Capacity after 12 month storage	64%
Terminal		T20
Charge (constant Voltage)	Cycle	Initial Charging Current less than 375 A Voltage 2.35-2.40V
	Float	Voltage 2.25-2.30V

● Outer dimensions (mm)

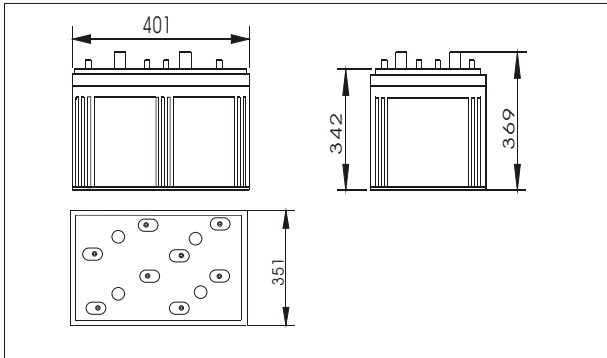

● Terminal Type (mm)

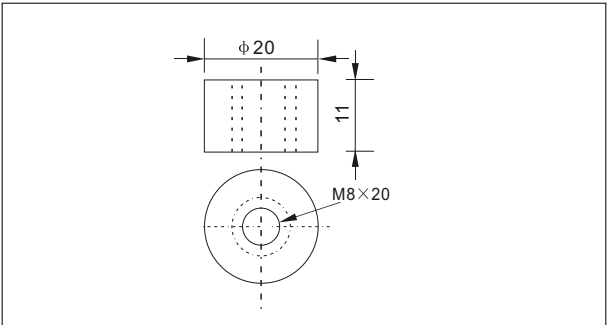

● Discharge Curves 25°C(77°F)

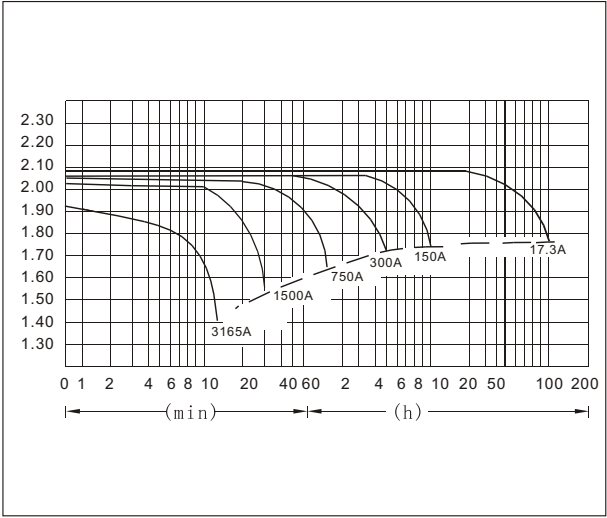

Constant Current(Amp) and Constant Power(Watt)Discharge Table at 25°C(77°F)												
Time		10min	30min	1h	3h	4h	5h	8h	10h	20h	50h	100h
1.60V	A	3165	1710	900	385.5	300.0	247.5	174.5	157.5	85.05	35.4	18.2
	W	5858	3053	1737	744	579	478	337	304	164.1	70.3	36.0
1.70V	A	3075	1665	846.0	375.0	292.5	243.0	170.7	153.6	82.95	34.2	17.7
	W	5634	3025	1633	724	565	469	329	296	160.1	67.8	35.0
1.75V	A	2939	1584	819	366.0	288.0	240.0	169.5	150.0	81.90	33.6	17.3
	W	5460	2855	1581	706	556	463	327	293	158.1	66.8	34.3
1.80V	A	2745	1532	792	357.0	283.5	234.0	165.0	146.3	81.00	33.0	17.1
	W	5248	2747	1511	693	544	454	320	291	157.1	65.5	34.0
1.85V	A	2520	1410	746	345.0	275.0	228.0	160.5	142.50	76.95	32.4	16.5
	W	5158	2725	1472	684	542	452	318	283	152.6	64.3	32.8