



Approved by:

Checked by:

Issued by:

SPECIFICATION

PRODUCT: SAW FILTER

MODEL: HB3612S (X6872D) SIP5D

HOPE MICROELECTRONICS CO., LIMITED

1. Construction

1.1 Dimension and materials

Type : B3612S



Unit : mm

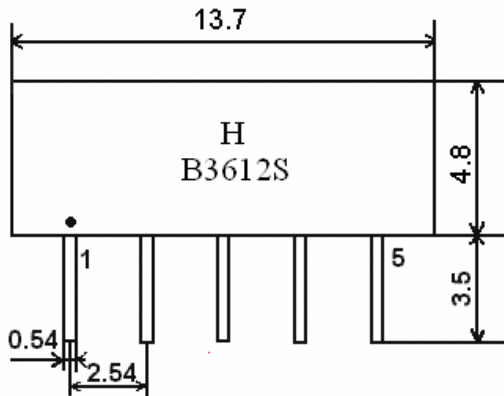

- 1 Input
- 2 Input ground
- 3 Chip carrier - ground bond
- 4 Output
- 5 Output

1.2. Circuit construction, measurement circuit

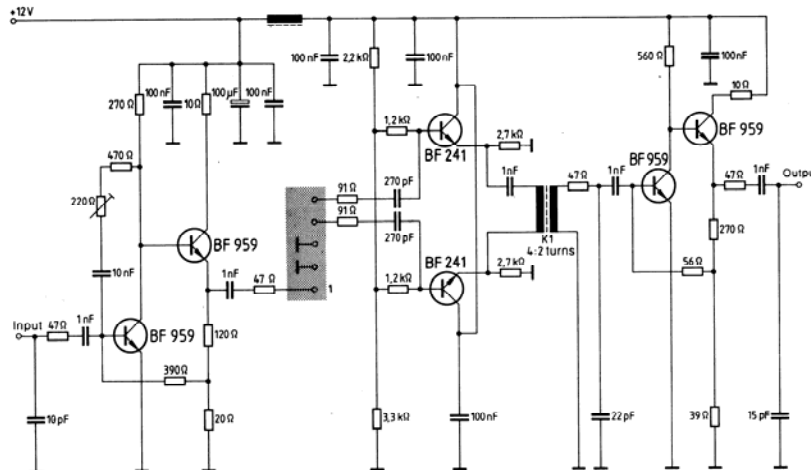

Test circuit for SIP-5 filter
Input impedance of the symmetrical post-amplifier: 2 kΩ in parallel with 3 pF

2.Characteristics

Standard atmospheric conditions

Unless otherwise specified , the standard rang of atmospheric conditions for making measurements and tests is as follows;

- Ambient temperature : 15°C to 35°C
- Relative humidity : 25% to 85%
- Air pressure : 86kPa to 106kPa

Operating temperature rang

Operating temperature rang is the rang of ambient temperatures in which the filter can be operated continuously. $-10^{\circ}\text{C} \sim +60^{\circ}\text{C}$

Storage temperature rang

Storage temperature rang is the rang of ambient temperatures at which the filter can be stored without damage.

Conditions are as specified elsewhere in these specifications. $-40^{\circ}\text{C} \sim +70^{\circ}\text{C}$

Reference temperature $+25^{\circ}\text{C}$

2.1 Maximum Rating

DC voltage	VDC	12	V	Between any terminals
AC voltage	Vpp	10	V	Between any terminals

2.2 Electrical Characteristics

Source impedance $Z_S=50\ \Omega$

Load impedance $Z_L=2\text{k}\ \Omega // 3\text{pF}$ $T_A=25^{\circ}\text{C}$

Item	Freq	min	typ	max	
Center frequency	Fo	-	36.125	-	MHz
Insertion attenuation Reference level	36.13MHz	18.0	20.0	22.0	dB
Pass bandwidth	B _{3dB}	-	6.9	-	MHz
	B _{30dB}	-	8.5	-	MHz
Relative attenuation	33.08MHz	-	0.5	-	dB
	39.17MHz	-	0.6	-	dB
	32.63MHz	-	3.6	-	dB
	39.63MHz	-	3.8	-	dB
Sidelobe	25.00~31.65MHz	35.0	46.0	-	dB
	40.65~45.00MHz	34.0	42.0	-	dB
Reflected wave signal suppression 1.2 us ... 6.0 us after main pulse (test pulse 250 ns , carrier frequency 36.13 MHz)		42.0	52.0		dB
Feedthrough signal suppression 1.3 us ... 1.2 us before main pulse (test pulse 250 ns , carrier frequency 36.13 MHz)		45.0	54.0		dB
Group delay ripple (p-p) 32.63 ~ 39.63 Mhz		-	50	-	ns
Impedance at 36.13 Mhz		-	-	-	-
Input: $Z_{in} = R_{in} // C_{in}$		-	3.4//13.3	-	k Ω // pF
Output: $Z_{in} = R_{in} // C_{in}$		-	2.2//4.3	-	k Ω // pF
Temperature coefficient of frequency			-72		ppm/k

2.3 Environmental Performance Characteristics

Item Test condition	Allowable change of absolute Level at center frequency(dB)
High temperature test 70°C 1000H	< 1.0
Low temperature test -40°C 1000H	< 1.0
Humidity test 40°C 90-95% 1000H	< 1.0
Thermal shock -20°C==25°C==80°C 20 cycle 30M 10M 30M	< 1.0
Solder temperature test Sold temp.260°C for 10 sec.	< 1.0
Soldering Immerse the pins melt solder at 260°C+5/-0°C for 5 sec.	More then 95% of total area of the pins should be covered with solder

2.4 Mechanical Test

Item Test condition	Allowable change of absolute Level at center frequency(dB)
Vibration test 600-3300rpm amplitude 1.5mm 3 directions 2 H each	<1.0
Drop test On maple plate from 1 m high 3 times	<1.0
Lead pull test Pull with 1 kg force for 30 seconds	<1.0
Lead bend test 90° bending with 500g weigh 2 times	<1.0

2.5 Voltage Discharge Test

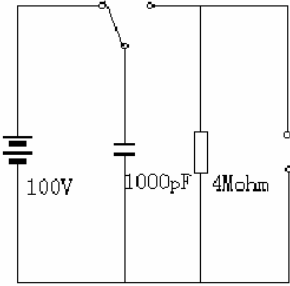
Item Test condition	Allowable change of absolute Level at center frequency(dB)
Surge test Between any two electrode 	<1.0

2.6 Frequency response:

