



Approved by:

Checked by:

Issued by:

SPECIFICATION

PRODUCT: SAW FILTER

MODEL: HB3613D (X6966D) SIP5D

HOPE MICROELECTRONICS CO., LIMITED

1. Construction

1.1 Dimension and materials

Type : B3613D

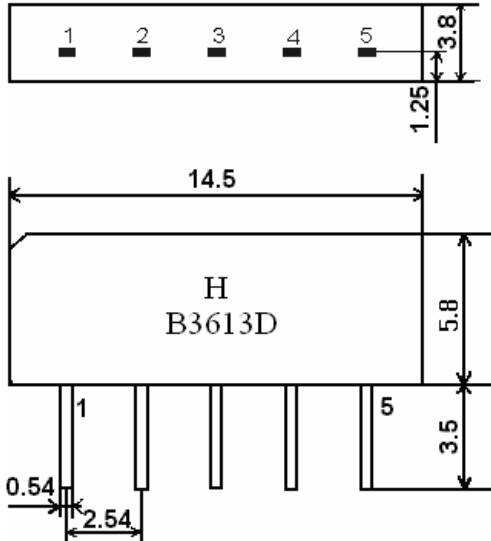

Unit : mm

- 1 Input
- 2 Input ground
- 3 Chip carrier - ground
- 4 Output
- 5 Output

1.2. Circuit construction, measurement circuit

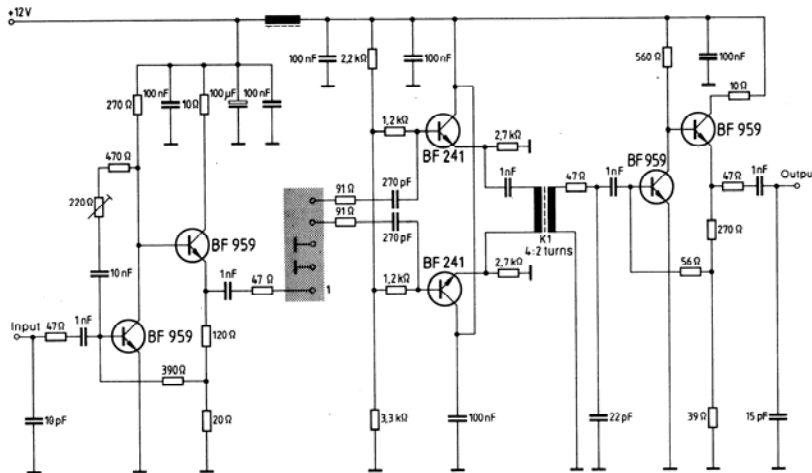

Test circuit for SIP-5 filter
Input impedance of the symmetrical post-amplifier: 2 kΩ in parallel with 3 pF

2.Characteristics

Standard atmospheric conditions

Unless otherwise specified , the standard range of atmospheric conditions for making measurements and tests is as follows;

- Ambient temperature : 15°C to 35°C
- Relative humidity : 25% to 85%
- Air pressure : 86kPa to 106kPa

Operating temperature rang

Operating temperature rang is the rang of ambient temperatures in which the filter can be operated continuously. $-10^{\circ}\text{C} \sim +60^{\circ}\text{C}$

Storage temperature rang

Storage temperature rang is the rang of ambient temperatures at which the filter can be stored without damage.

Conditions are as specified elsewhere in these specifications. $-40^{\circ}\text{C} \sim +70^{\circ}\text{C}$

Reference temperature $+25^{\circ}\text{C}$

2.1 Maximum Rating

DC voltage	VDC	12	V	Between any terminals
AC voltage	Vpp	10	V	Between any terminals

2.2 Electrical Characteristics

Source impedance $Z_S=50\ \Omega$

Load impedance $Z_L=2\text{k}\ \Omega // 3\text{pF}$ $T_A=25^{\circ}\text{C}$

Item	Freq	min	typ	max	
Center frequency	Fo	36.05	36.125	36.20	MHz
Insertion attenuation Reference level	36.125MHz	18.3	20.3	22.3	dB
Pass bandwidth	B1dB	-	7.5	-	MHz
	B3dB	-	8.0	-	MHz
	B30dB	-	9.4	-	MHz
Relative attenuation	32.32MHz	-	1.2	-	dB
	39.93MHz	-0.4	1.1	2.6	dB
	32.13MHz	1.6	3.1	4.6	dB
	40.13MHz	1.7	3.2	4.7	dB
	31.25MHz	35.0	48.0	-	dB
	47.25MHz	40.0	52.0	-	dB
Sidelobe	25.00~29.50MHz	35.0	41.0		dB
	29.50~31.25MHz	31.0	37.0		dB
	40.90~43.50MHz	31.0	37.0		dB
	43.50~50.00MHz	35.0	42.0		dB
Reflected wave signal suppression 1.2 us ... 6.0 us after main pulse (test pulse 250 ns , carrier frequency 36.125 MHz)		42.0	52.0		dB
Feedthrough signal suppression 1.3 us ... 1.2 us before main pulse (test pulse 250 ns , carrier frequency 36.125 MHz)		45.0	54.0		dB
Group delay ripple (p-p) 32.13 ~ 40.13 Mhz		-	50	-	ns

Impedance at 36.125 Mhz	-	-	-	-
Input: $Z_{in} = R_{in} // C_{in}$	-	2.9//14.1	-	k Ω // pF
Output: $Z_{in} = R_{in} // C_{in}$	-	2.4//4.4	-	k Ω // pF
Temperature coefficient of frequency	-72			ppm/k

2.3 Environmental Performance Characteristics

Item Test condition	Allowable change of absolute Level at center frequency(dB)
High temperature test 70°C 1000H	< 1.0
Low temperature test -40°C 1000H	< 1.0
Humidity test 40°C 90-95% 1000H	< 1.0
Thermal shock -20°C==25°C==80°C 20 cycle 30M 10M 30M	< 1.0
Solder temperature test Sold temp.260°C for 10 sec.	< 1.0
Soldering Immerse the pins melt solder at 260°C+5/-0°C for 5 sec.	More then 95% of total area of the pins should be covered with solder

2.4 Mechanical Test

Item Test condition	Allowable change of absolute Level at center frequency(dB)
Vibration test 600-3300rpm amplitude 1.5mm 3 directions 2 H each	<1.0
Drop test On maple plate from 1 m high 3 times	<1.0
Lead pull test Pull with 1 kg force for 30 seconds	<1.0
Lead bend test 90° bending with 500g weigh 2 times	<1.0

2.5 Voltage Discharge Test

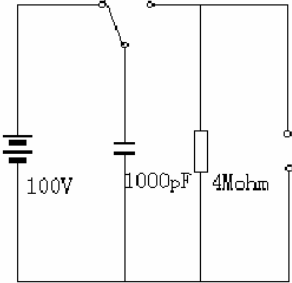
Item	Allowable change of absolute
Test condition	Level at center frequency(dB)
Surge test Between any two electrode	<1.0
	

2.6 Frequency response:

►1: Transmission /M Log Mag 10.0 dB/ Ref -20.75 dB
 ►2: Off

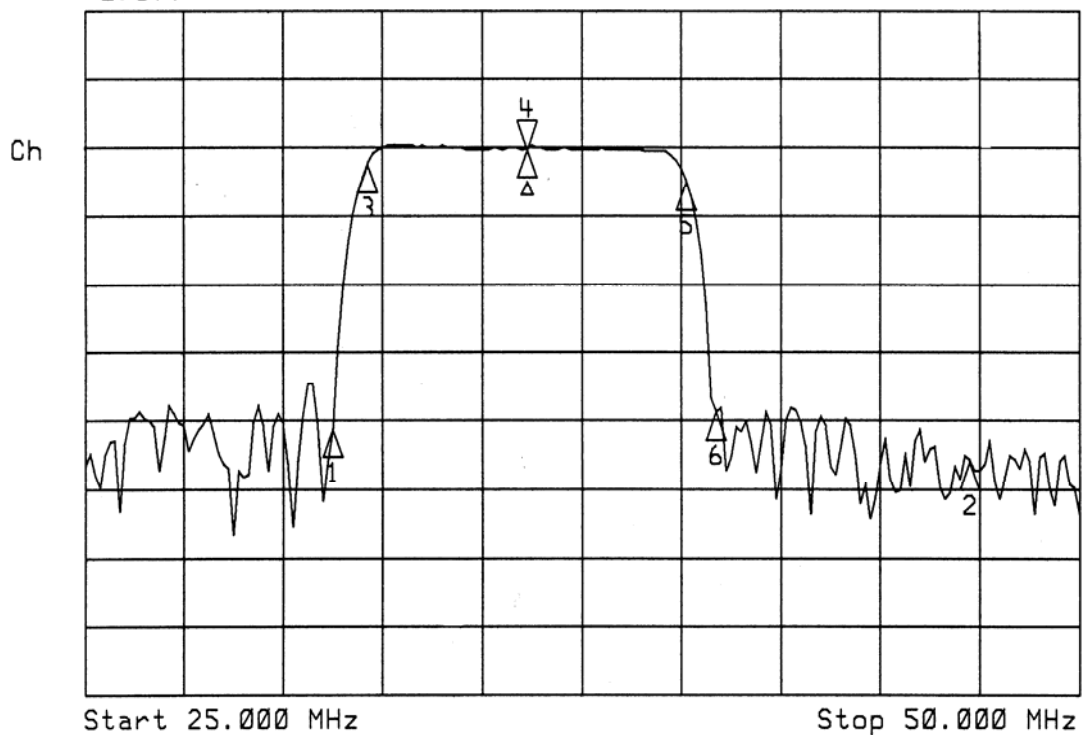

Mkr	ΔFreq (MHz)	Ch 1 (dB)	Freq (MHz)	Ch 2 (dB)
1	-4.875	-41.12		
2	11.125	-45.78		
3	-3.995	-2.10		
4	0.000	0.00		
5	4.005	-4.82		
6	4.775	-38.51		
7				
8				

CH1 S21 log MAG 1 dB/ REF -20.71 dB 2: -.0028 dB
 CH2 S21 delay 30 ns/ REF 1.311 ps 2 127.1 ps

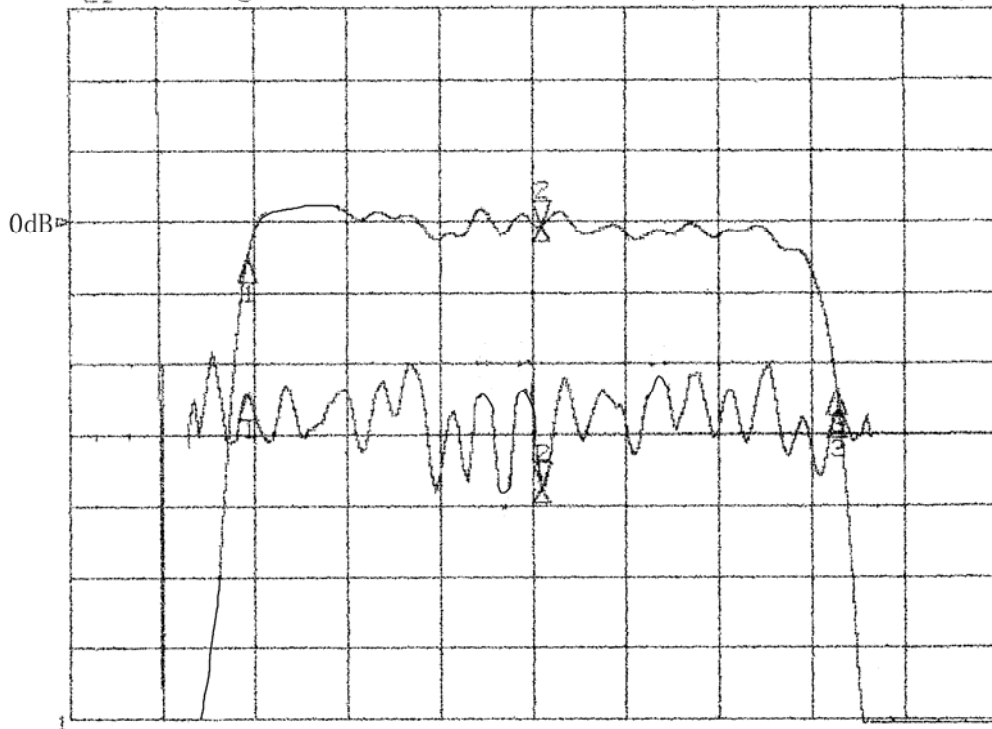

START 30.000 000 MHz STOP 42.000 000 MHz

►1: Transmission /M Log Mag 10.0 dB/ Ref -21.32 dB

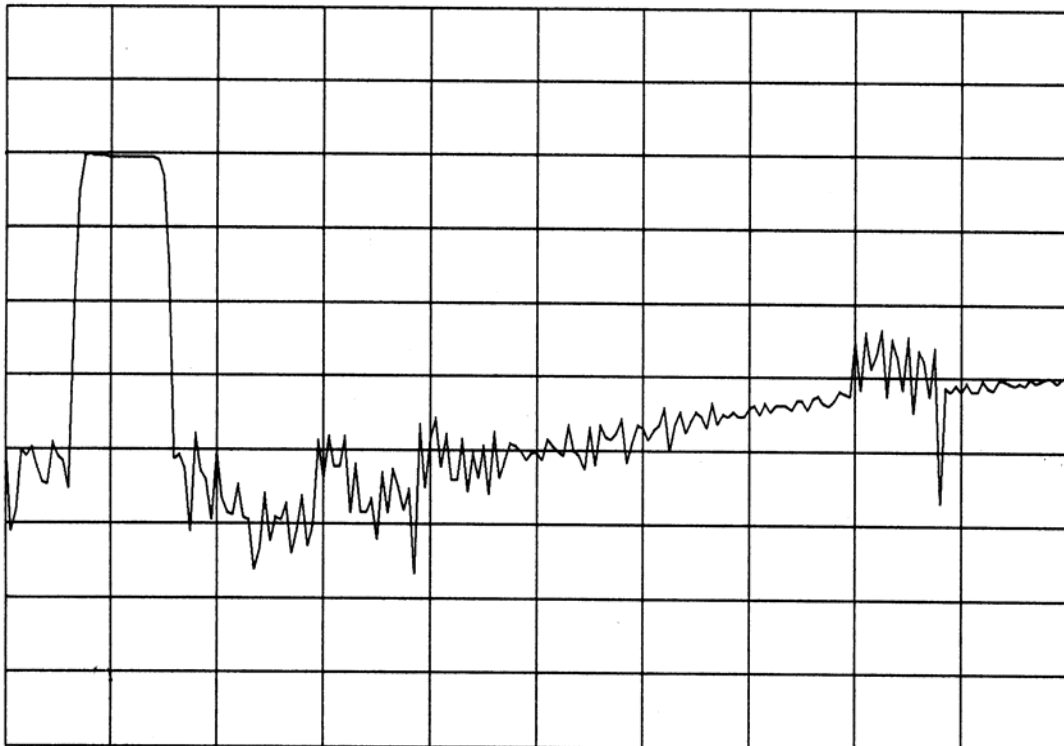

Start 25.000 MHz

Stop 125.000 MHz