

IRPLCFL8U

Simplified Three Level Dimming CFL Fluorescent Ballast using the IRS2530D *DIM8*TM

Table of Contents

| | Page |
|---|-------------|
| 1. Features | 2 |
| 2. Overview | 2 |
| 3. Circuit Schematic | 8 |
| 4. Electrical Characteristics | 9 |
| 5. Fault Protection Characteristics | 9 |
| 6. Functional Description..... | 10 |
| 7. Fault Conditions | 15 |
| 8. Ballast Design | 19 |
| 9. Bill of Materials..... | 22 |
| 10. IRPLCFL8U PCB Layout..... | 23 |
| 11. Inductor Specifications | 27 |

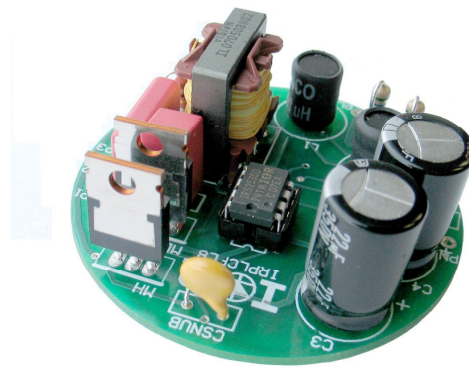

1. Features

- Drives 1 x 32W Spiral CFL Lamp
- Input Voltage: 120Vac
- High Frequency Operation
- Lamp Filament Preheating
- Lamp Fault Protection with Auto-Restart
- Low AC Line/Brownout Protection
- IRS2530D DIM8™ HVIC Ballast Controller

2. Overview

The 3 way dimming system widely adopted in the US with conventional filament lamps consists of a light bulb that has a modified Edison screw type base which allows 3 connections to be made to a special lamp socket that also has 3 connections.

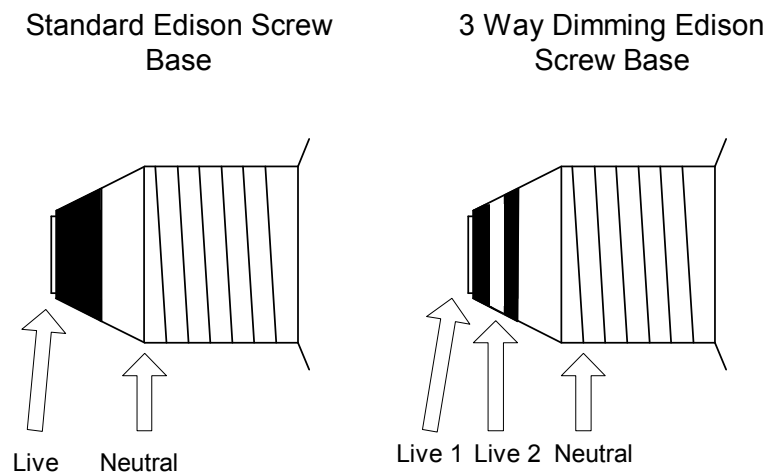

Figure 2.1: Three way dimming Edison screw base

The 3 way dimming light bulb has two filaments inside which produce different light outputs when connected to the AC line. These filaments are connected in series such that the mid point goes to the line common and the two ends can be connected to the live

either independently or both together. Thus with an external switch that has four positions, it is possible to obtain 3 different light levels or to switch off.

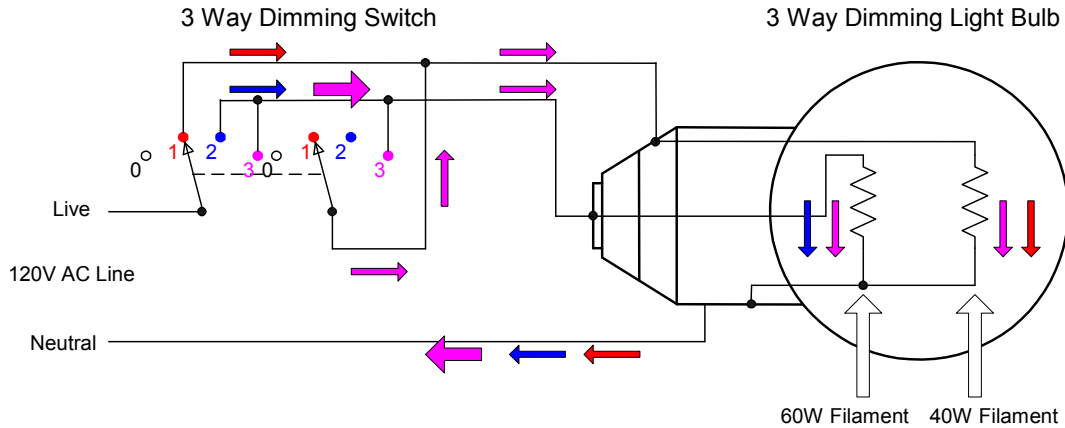

Figure 2.2: Three way dimming filament lamp system

Figure 2.2 shows how the live and the neutral connect for 4 different configurations (position 0, 1, 2, and 3). The flow of current for each position is also shown with colored arrow; no current flows for position 0 (switch off), red arrow for position 1, blue arrow for position 2, and magenta arrow for position 3. In position 1, the current will flow through the 40W filament resistor (the lowest dimming level). In position 2, the current will flow through the 60W filament resistor (intermediate dimming level). In position 3, current will flow through both filaments, and the system will be at the maximum dimming level.

Existing Ballast Solution

There are in existence CFL ballast designs that provide three way dimming based on the same switching arrangement shown above. A common approach is a system whereby the line voltage is full wave rectified when one live input is connected and a voltage doubler circuit comes into operation when the other live input is connected or both are connected together thereby having two DC bus voltages in the ballast during dim level settings. This type of design also operates at two different frequencies, a low frequency (typically 40-45kHz) when both live inputs are connected providing a high lamp current and a higher frequency (for example 70-75kHz) when either of the two lives is connected alone which will produce a lower lamp current. In this way the following combinations are achieved:

1. Low DC bus (150V) / high frequency minimum output
2. High DC bus (300V) / high frequency medium output
3. High DC bus (300V) / low frequency maximum output

This approach has some serious drawbacks:

Firstly, since the ballast must be designed to give 100% light output for the lamp when the bus voltage is 300V and the frequency is 40kHz, it is not easy to achieve satisfactory preheat and ignition when the bus voltage is at 150V because of the limitations in the peak voltage that the output circuit is able to produce from a 150Vpp half bridge voltage.

One strategy that has been used is to omit the preheating phase and steer the oscillator frequency to resonance during ignition using feedback from the output circuit. This ensures that at switch-on the highest possible ignition voltage will be applied to the lamp. In this way the lamp will ignite in whichever position the 3 way switch is set.

Such a scheme could reliably ignite the lamp when the DC bus is at 300V, however without correct preheating the ignition voltage of the lamp and consequently the peak current in the MOSFET half bridge during ignition will be higher. Also the life of the lamp is substantially reduced when there is no preheat due to far greater stress occurring on the cathodes at the point of ignition.

Ignition when the DC bus voltage is at 150V is very difficult. Tests indicated that sweeping the frequency down through resonance sometimes failed to produce sufficient ignition voltage leaving the ballast in open circuit running mode. The conclusion from this is that the ballast needs to oscillate at resonance for an extended period of time in order for the lamp to ignite at 150V considering that the output inductor and capacitor have been designed to produce 100% lamp power at 300VDC bus when the frequency is 40-45kHz.

Many CFL ballast designs do not incorporate a current sense and shutdown function to protect the circuit in the case of ignition failure and so the ballast would eventually fail if left switched on due to the high MOSFET switching losses causing thermal destruction. This would not matter with an integrated ballast / lamp type product when the lamp has failed.

It has also been observed that hard switching occurs at the MOSFET half bridge when the DC bus voltage is low in position 1 since when the ballast is running it will be close to resonance, bearing in mind that the resonant frequency shifts downwards in run mode. Hard switching is very undesirable because of the high peak currents that occur when each MOSFET switches on. This has been shown to result in a higher rate of field failures in ballasts due to MOSFET failure.

The conclusion is that the approach to design described above is unable to provide a reliable ballast.

The dimming level can also be controlled by simply changing the frequency. By changing the frequency between 3 defined settings, however, it was found to be extremely difficult to set a point where the dim level is 50%. The problem with this is that the lamp current against ballast frequency characteristic of the system exhibits a very sharp knee such that as the frequency increases the lamp current is gradually reduced up to a point at which a small increase of frequency will result in a very large reduction in the lamp current.

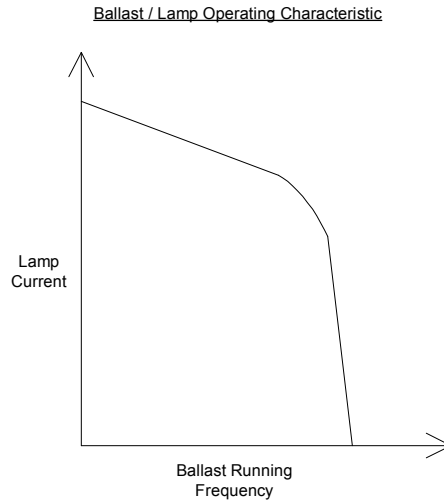

Figure 2.3: Lamp current against ballast frequency

To obtain 50% output, the frequency would have to be very precisely set. This is not practical since the tolerances of the output inductor, capacitor and oscillator timing components do not allow this. Even if each ballast was individually adjusted in production variations in lamp behavior over temperature would mean that under some conditions the lamp arc would extinguish at this setting leaving the system in permanent preheat which would burn out the cathodes eventually.

This explains why the 150VDC bus solution has been adopted in some designs as this allows 50% output to be achieved without this problem. However as discussed in the previous section this approach is not without some major disadvantages.

IRPLCFL4 Reference Design

It is however necessary in order to create a reliable design to include a closed loop feedback system that controls the lamp current by adjusting the ballast frequency from a VCO (voltage controlled oscillator) driven by the output of an error amplifier that senses the lamp arc current directly and compares it with a reference. This has been used in the [IRPLCFL4](#) reference design “A 3 Way Dimming CFL Ballast” and has been demonstrated to be capable of controlling the lamp output down to approximately 10% arc current maintaining stability. This also compensates for tolerances in the components of the circuit or the lamp.

Regulated Lamp Current Control System

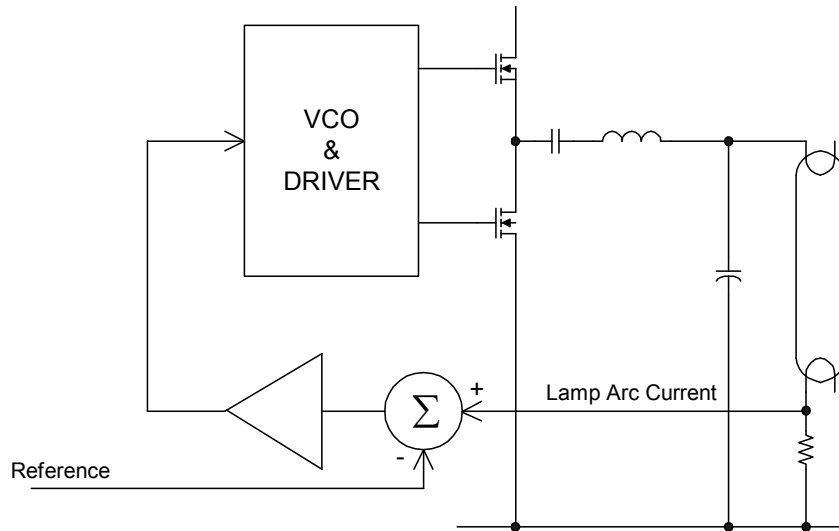

Figure 2.4: Closed loop lamp arc current regulation

Many of the design issues described above have also been overcome in the ballast circuit of reference design IRPLCFL4. The design, however, required two additional operational amplifiers and additional circuitry since it is based on the [IR2156](#) control IC, which does not incorporate the necessary dimming circuitry. This circuit therefore has a relatively high component count.

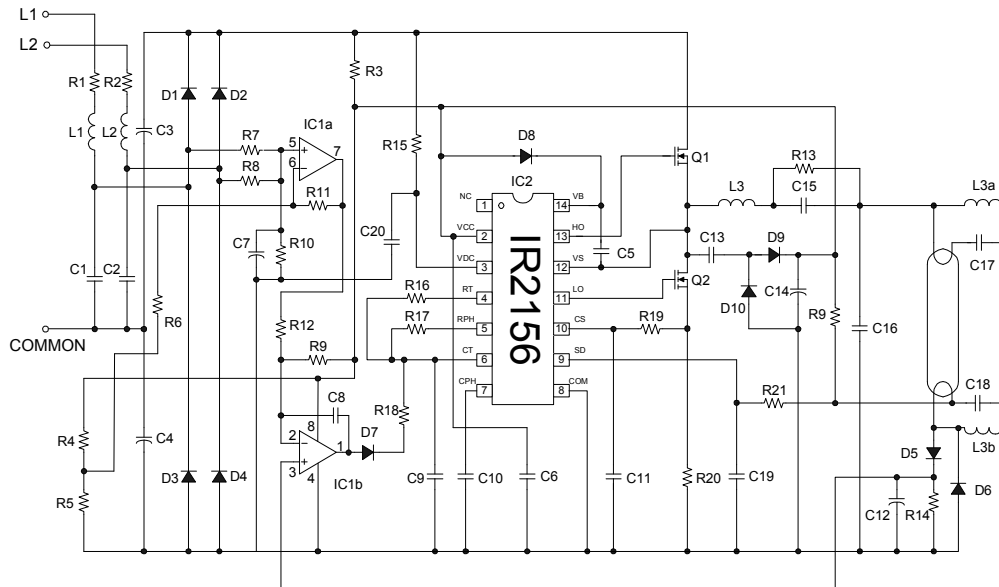

Figure 2.5: IRPLCFL4 Circuit Schematic

The component count for the IRPLCFL4 design shown in figure 2.5 is 56 parts.

New Solution: IRPLCFL8U

A completely new approach has been developed that overcomes all of the above limitations. The IRPLCFL8U reference design kit consists of a dimming Fluorescent ballast, with a 3 way dimming switch, driving a single 32W CFL lamp. The design contains an EMI filter and a dimming ballast control circuit using the [IRS2530D\(DIM8™\)](#). The component count for the IRPLCFL8U, shown in figure 3.1, is 50 parts. This demo board is intended to help with the evaluation of the IRS2530D dimming ballast control IC, demonstrate PCB layout techniques and serve as an aid in the development of production ballasts using the IRS2530D.

3. Circuit Schematic

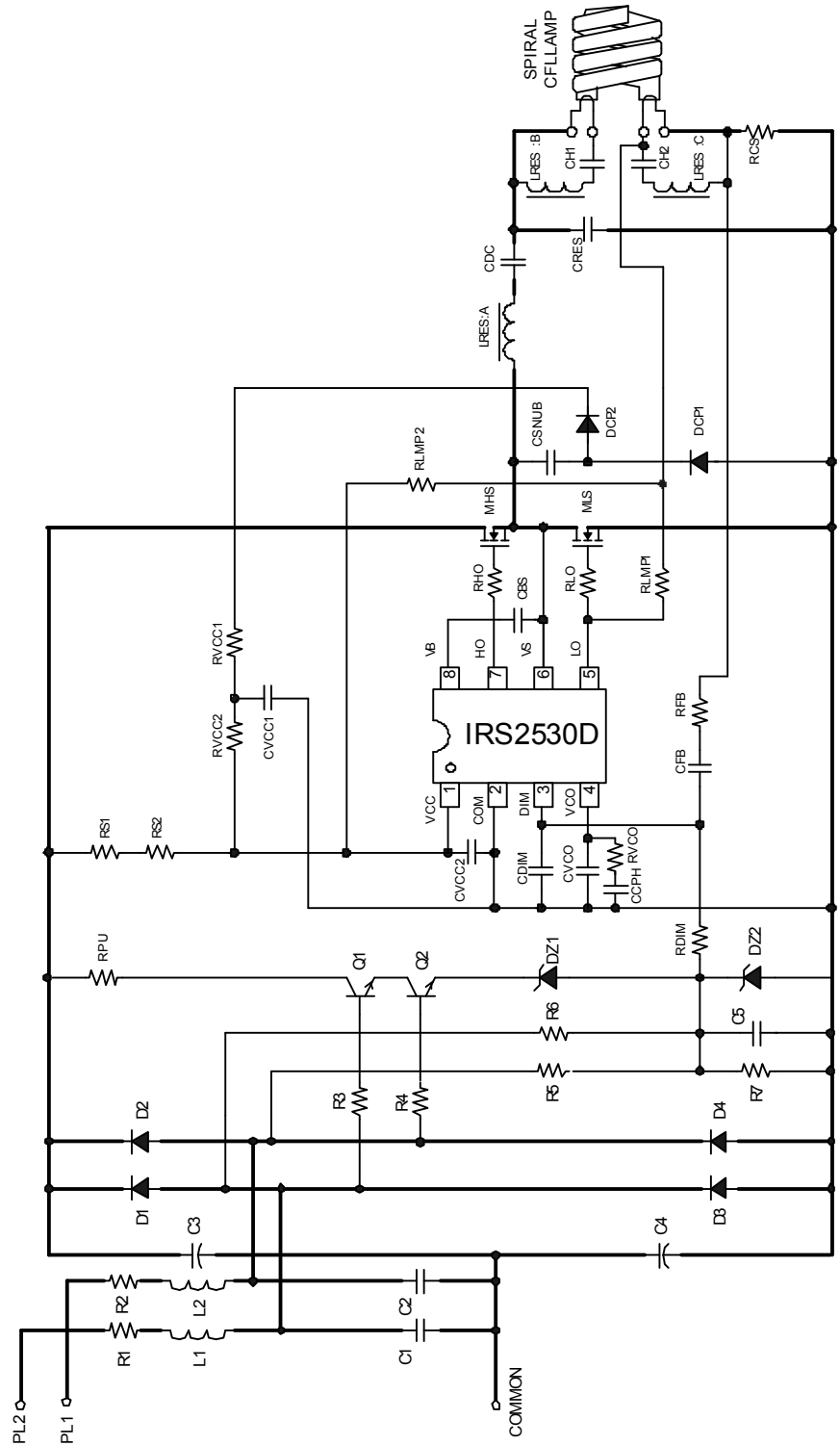

Figure 3.1: IRPLCFL8U Circuit Schematic

4. Electrical Characteristics

| Parameter | Units | Dimming Level | Value |
|--------------------------|----------|---------------|----------|
| Lamp Type | | | 32W CFL |
| Input Power | [W] | Maximum | 31 |
| | | Intermediate | 22 |
| | | Minimum | 15 |
| Input Current | [mArms] | Maximum | 386 |
| | | Intermediate | 260 |
| | | Minimum | 175 |
| Lamp Running Voltage | [Vpp] | Maximum | 370 |
| | | Intermediate | 540 |
| | | Minimum | 630 |
| Lamp Running Current | [mArms] | Maximum | 190 |
| | | Intermediate | 80 |
| | | Minimum | 27 |
| Start Frequency | [kHz] | | 115 |
| Run Frequency | [kHz] | Maximum | 42 |
| | | Intermediate | 59 |
| | | Minimum | 60 |
| Preheat Time | [s] | | 0.5 |
| Input AC Voltage Range | [VACrms] | | 60 - 180 |
| Ballast turn-off voltage | [VACrms] | | 60 |

TABLE 4.1: Ballast Parameters.

5. Fault Protection Characteristics

| Fault | Protection | Ballast | Restart Operation |
|-----------------------|---------------------------|--------------------|-----------------------|
| Brown-out | Non-ZVS | Increase frequency | Line voltage increase |
| Upper filament broken | Crest Factor Over Current | Deactivates | Lamp exchange |
| Lower filament broken | Crest Factor Over Current | Deactivates | Lamp exchange |
| Lamp removed | Crest Factor Over Current | Deactivates | Lamp inserted |
| Failure to ignite | VVCOFLT+ | Deactivates | Lamp exchange |
| No lamp | VLOSD- | Does not start | Lamp inserted |
| End of life | Crest Factor Over Current | Deactivates | Lamp exchange |

TABLE 5.1: Fault Protections Characteristics.

6. Functional Description

The IRS2530D design utilizes a voltage doubler at the front end in all modes of operation giving a fixed DC bus voltage approximately 300V. By correctly selecting value of the snubber capacitor it is not difficult to achieve soft switching in all modes of operation.

The front end of the IRPLCFL8U ballast circuit shows the neutral line input (i.e. the one that is always connected) connected to the center point of the DC bus storage capacitors C3 and C4. Live inputs L1 and L2 are connected to two completely separate voltage doubler diode pairs which are connected to the DC bus. These four diodes are all contained within the bridge BR1 (This is shown as D1, D2, D3 and D4 in the schematic of Fig 6). If live input L1 is connected to the line, a 60Hz sinusoidal AC voltage will be present at the point where the anode of D1 joins the cathode of D3. This voltage will swing between the 300V DC bus voltage and the 0V COM point of the circuit. If live input L1 is not connected to the line this point will be floating with only residual voltage present. The same applies with live input L2 at the point where the anode of D2 meets the cathode of D4. These two points are fed via resistors R5 and R6 to the parallel combination of R7 and C5, which are connected to 0V COM. The value of C5 is high enough to ensure that the amount of ripple that is present at the junction of C5 and RDIM will be negligible so a DC voltage will effectively appear there. This sets the reference voltage level for the dimming feedback loop.

As a result this dimming control voltage will change depending on whether live input L1 is connected only, live input L2 is connected only or both are connected, which depends on the three way dimming rotary switch position. The values of R5 and R6 will be chosen so that this voltage is substantially different if either live input L1 or live input L2 are connected alone and these values are selected to set the desired low and mid light levels. In this application R5 can be selected to give the correct reference voltage to provide 50% light output as perceived by the human eye, which occurs at a point somewhat lower than 50% ballast power and R6 can be chosen for 75% which is at about 50% of the nominal total ballast power at full light output.

The design problem overcome here is that the dimming control voltage obtained through R5 and R6, where the values have been selected to provide minimum and medium light outputs, is not sufficiently high to provide maximum light output when both live inputs are connected. This being the case it was necessary to add the two pull up transistors Q1 and Q2. When both inputs L1 and L2 are connected, i.e. when the rotary switch is in the fully on position, the voltage at RDIM will be pulled high enough to ensure that the ballast operates at maximum output since the transistors Q1 and Q2 will both be switched on in this case.

Q1 and Q2 are small signal NPN devices, however they need to be rated to 300V VCEO to prevent any conduction if either one is switched off. The zener diode DZ1 had been added to ensure that Q1 and Q2 can fully switch off. This is because even when not connected to the line some voltage appears at the bases of these devices. Since Q1 and Q2 are configured as emitter followers the base voltage must exceed the breakdown voltage of DZ1 (68V) in order to switch on, which can only occur when the corresponding line input is connected through the rotary switch.

The closed loop regulation dimming ballast section, unlike in the IRPLCFL4 design, is incorporated within the 8 pin package of the IRS2530D “simple dim” ballast controller greatly simplifying the circuit design.

Since we are sensing the lamp arc current with a resistor it is necessary to use voltage mode preheating to avoid detecting the sum of the current in the arc and the current in the resonant output capacitor CRES. This has an additional advantage that during preheat and prior to ignition of the lamp the arc current will always be zero and consequently the feedback circuit will not influence the oscillator frequency until the lamp is running. Consequently the preheat will occur in exactly the same way regardless of which of the live inputs are connected, thus achieving optimum preheat and ignition under all conditions.

A resistor parallel with CDC can be added if necessary to remove *striations* (dark rings) in the lamp that may occur at low dimming levels. However this has not been necessary in this reference design.

R1 and R2 are fusible resistors that are optional and L1, L2, C1 and C2 are recommended for EMI filtering but have no bearing on the functional operation of the ballast.

Figure 6.1 shows the voltage at the DIM pin for all 3 dimming level.

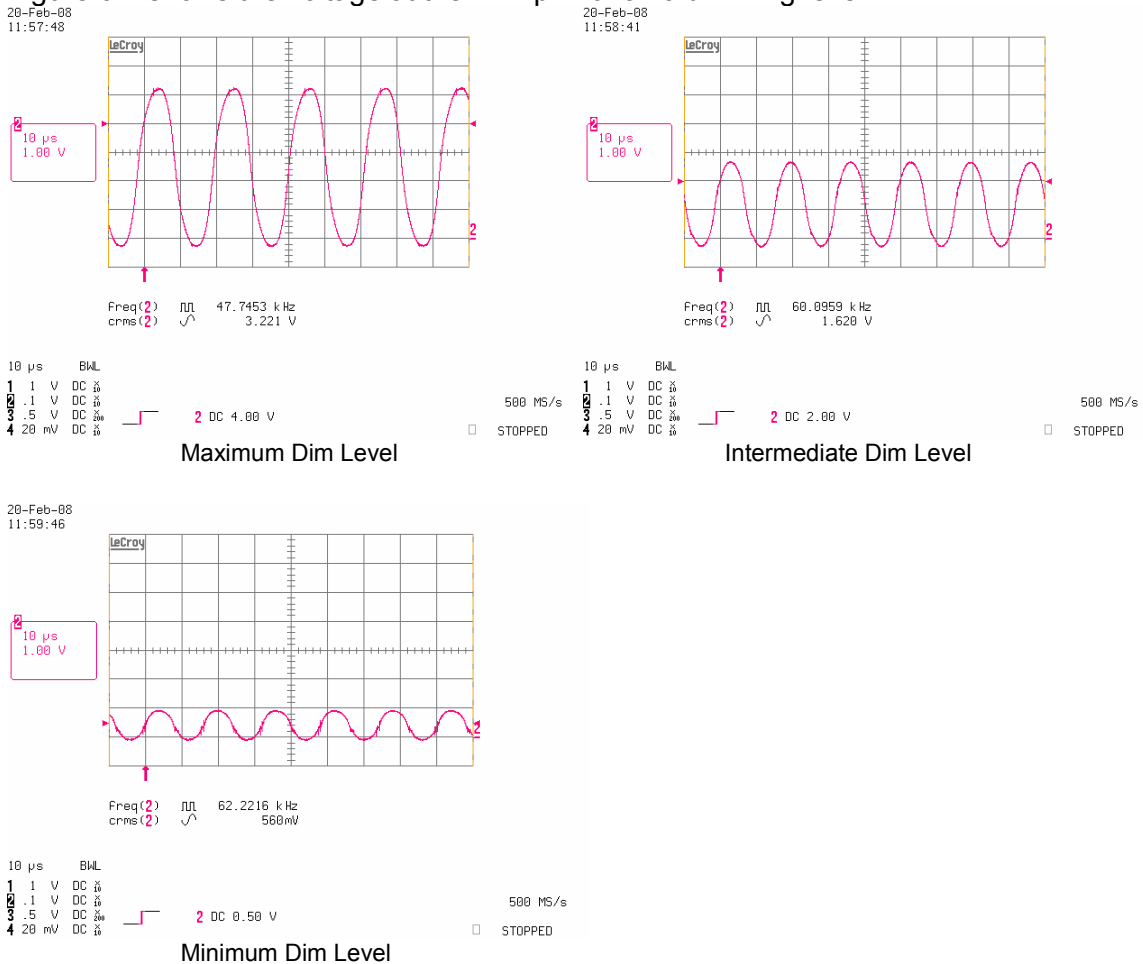

Figure 6.1: IRS2530D DIM pin voltages

Figure 6.2 shows the voltage at the VCO pin, and the VS (half-bridge) voltage for all 3 dimming level.

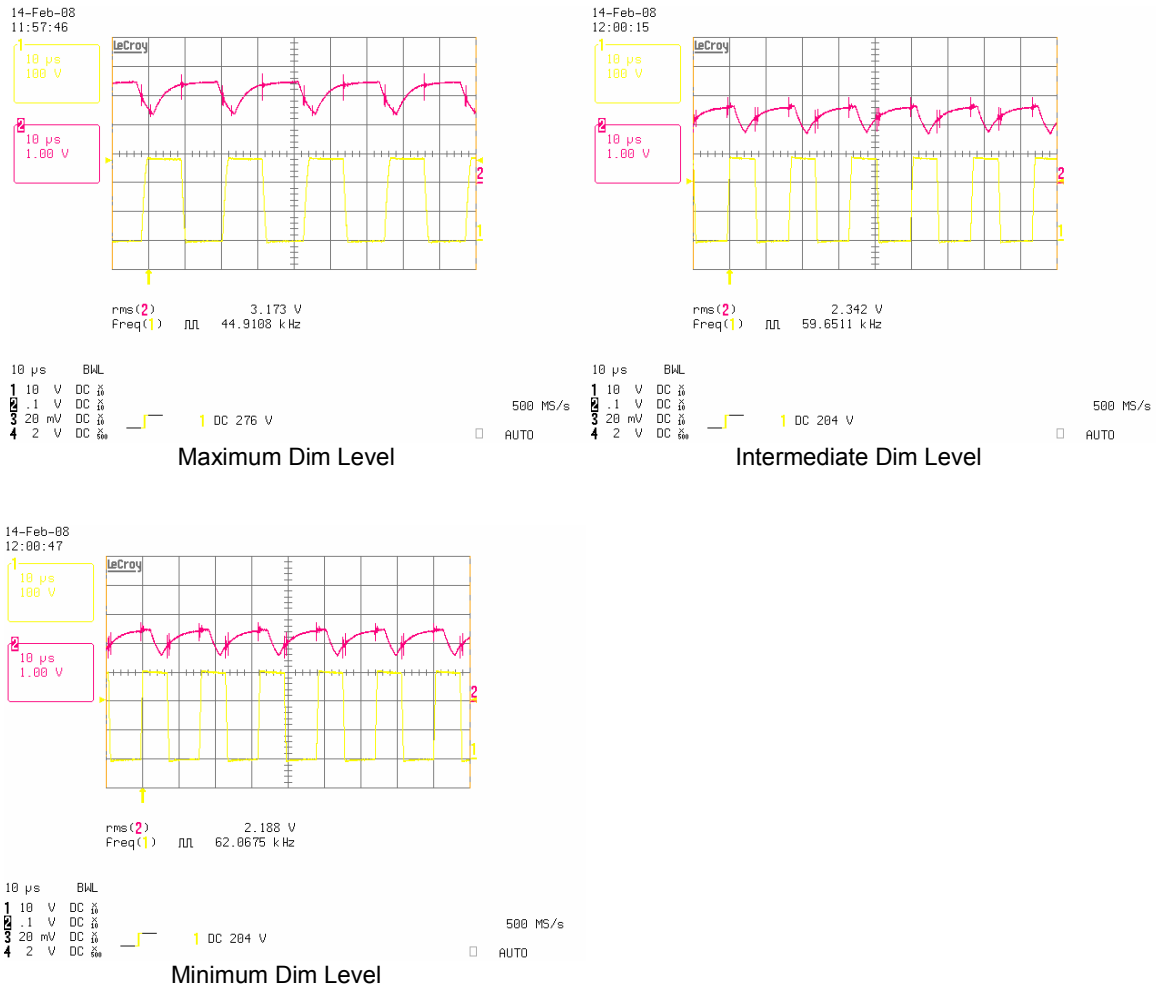

Figure 6.2: IRS2530D VCO (red) and VS (yellow) pin voltages

Figure 6.3 shows the voltage across the lamp, and the current through the lamp for all 3 dimming level.

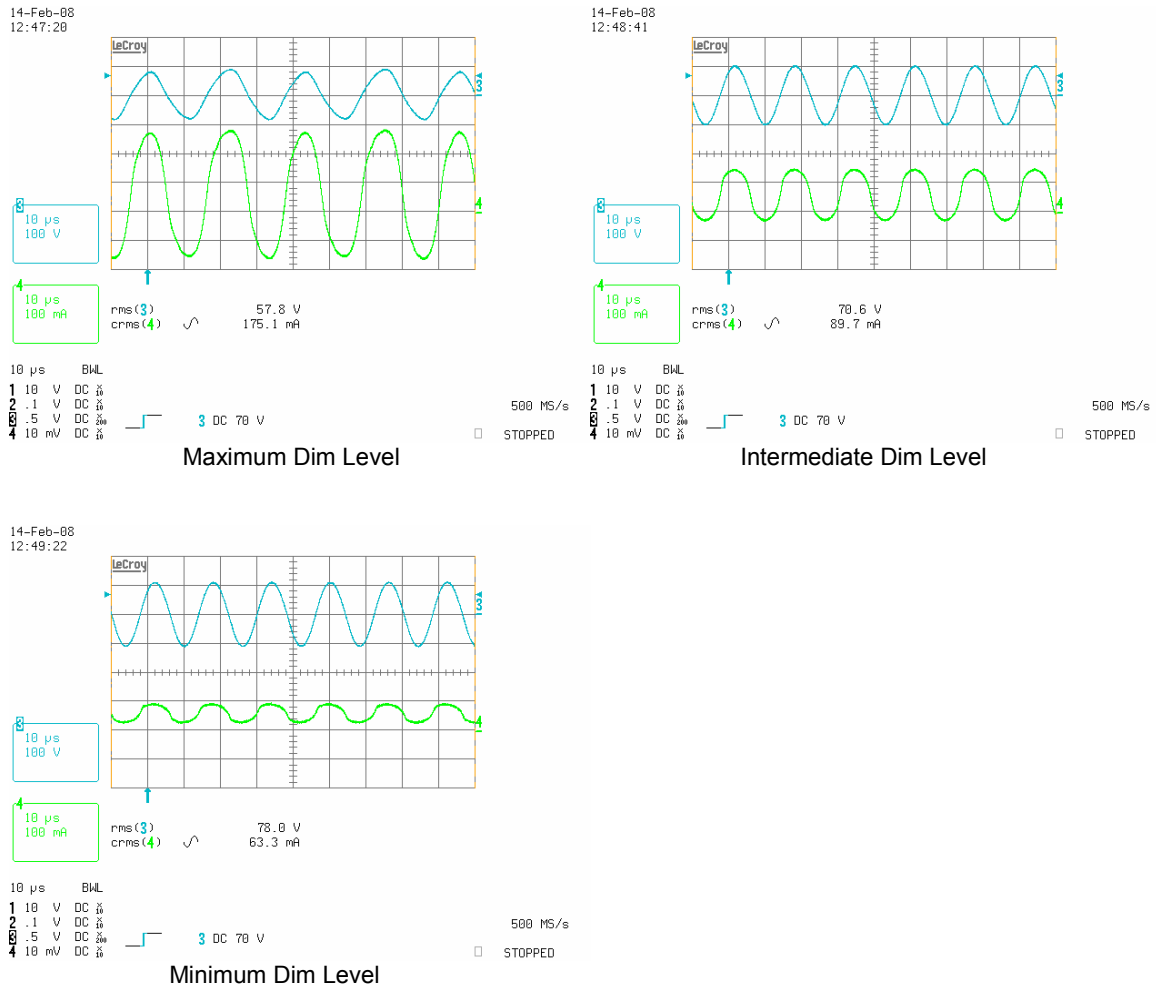

Figure 6.3: Lamp Voltage and Arc Current

14-Feb-08
12:54:33

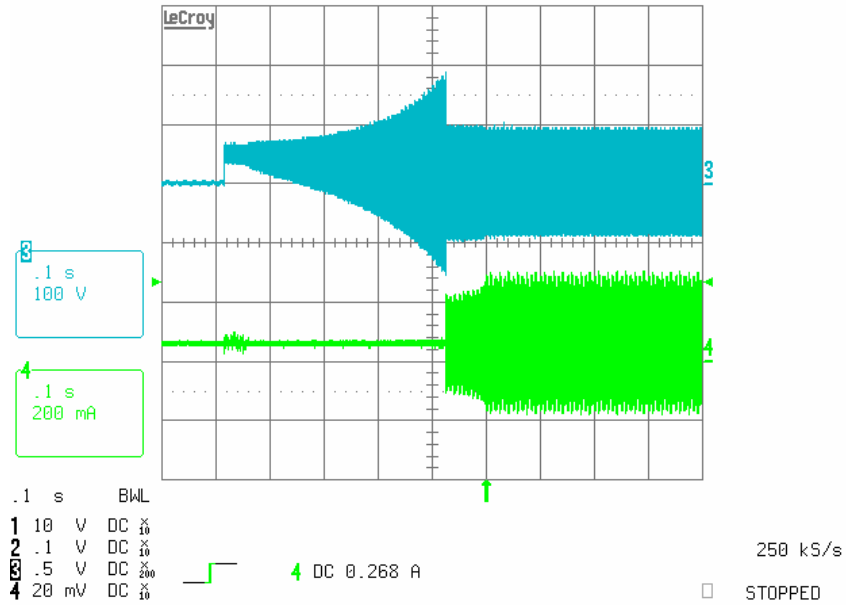

Figure 6.4: Lamp Voltage and Arc Current during preheat and ignition

7. Fault Conditions

In case of fault conditions such as open filaments, failure to strike, or lamp removal, the IRS2530D will go into Fault Mode. In this mode, the internal fault latch is set, HO is off, LO is open circuit, and the IRS2530D consumes an ultra-low micro-power current. The IRS2530D can be reset with a lamp exchange (as detected by the LO pin) or a recycling of VCC below and back above the UVLO thresholds.

Failure to Strike

At initial turn-on of the ballast, the frequency will ramp down from f_{MAX} toward the resonance frequency. When the lamp fails to strike, the VCO voltage continues to increase and the frequency continues to decrease until the VCO voltage exceeds VVCOFLT+ (4.0V, typical), and the IRS2530D enters Fault Mode and shuts down (Figure 7.1). It should be noted that in case of failure to strike, the system will operate in capacitive side of resonance, but only for short period of time.

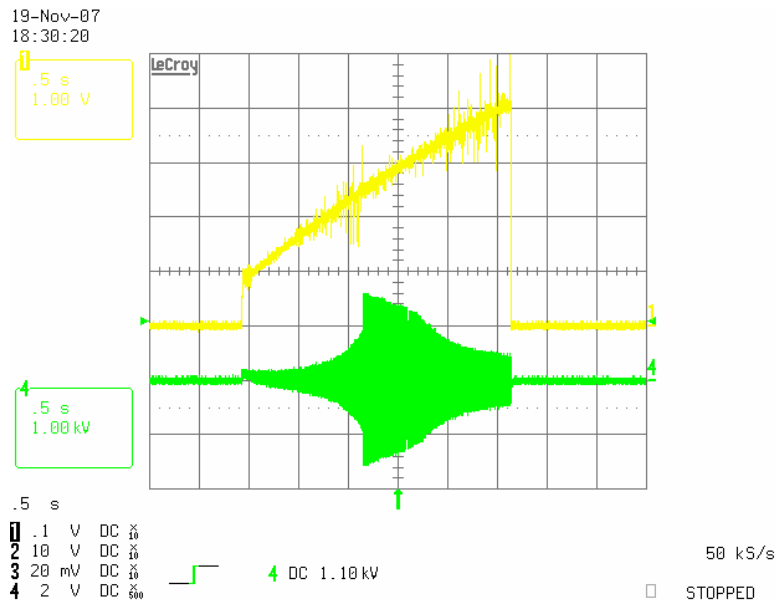

Figure 7.1: Lamp non-strike: CH1 is the VCO voltage, CH4 is the voltage across lamp

AC Mains Interrupt / Brown-Out Conditions

This protection relies on the non-ZVS circuit of IRS2530D, enabled in the Dim Mode. During an AC mains interrupt or brown-out condition, the DC bus can decrease and cause the system to operate too close to, or, on [the] capacitive side of resonance. The result is non-ZVS switching that causes high peak currents to flow in the half-bridge MOSFETs that can damage or destroy them.

To protect against this, the IRS2530D will detect non-ZVS by measuring the VS voltage at each rising edge of LO. If the voltage is greater than VZVSTH (4.5V, typical), the IC will reduce the voltage at VCO pin, and thus increase the frequency until ZVS is reached again (Figure 7.2).

In case the DC bus decreases too far and the lamp extinguishes, the VCC voltage will go below VCCUV- and the ignition/preheat ramp will be reset to re-ignite the lamp reliably.

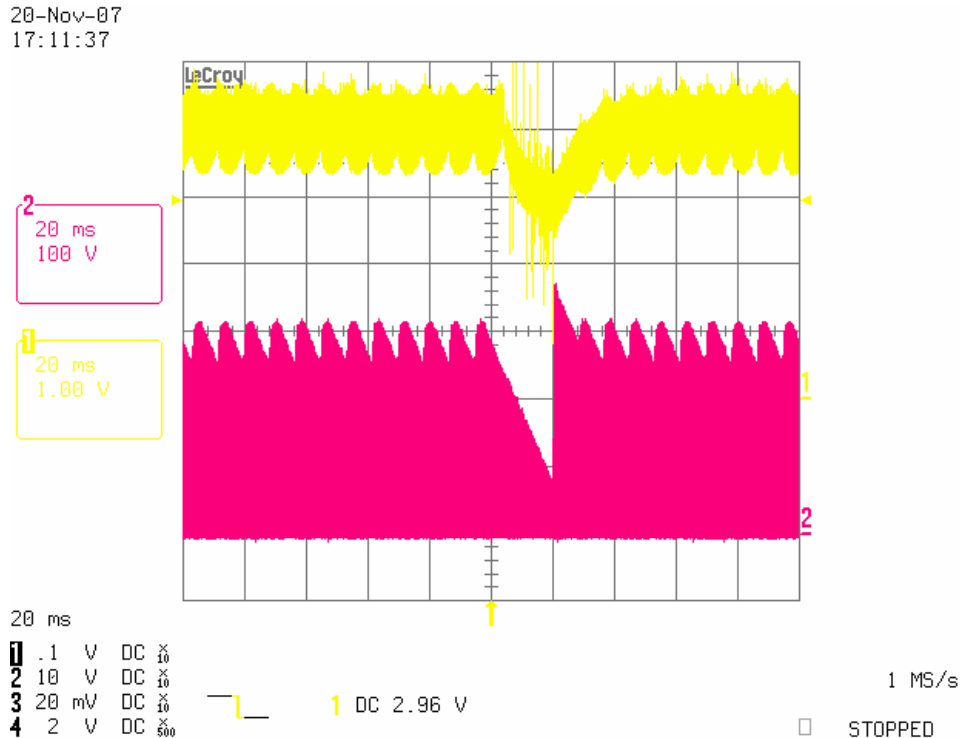

Figure 7.2: Brown-out conditions: CH1 is the VCO voltage, CH2 is the VS voltage

Lamp Removal

When the lamp is removed, the IRS2530D uses the Crest Factor Over-current Protection to enter the Fault mode and shut down. During lamp removal, the output stage will transition to a series-LC configuration, and the frequency will move towards resonance until the inductor saturates. The IRS2530D uses the VS-sensing circuitry and the R_{DSon} of the low-side half-bridge MOSFET to measure the MOSFET current for detecting an over-current fault. Should the peak current exceed the average current by a factor of 5.5 ($CF > 5.5$) during the on-time of LO, the IRS2530D will enter Fault Mode, where the half-bridge is off. Performing crest factor measurement provides a relative current measurement that cancels temperature and/or tolerance variations of the R_{DSon} of the low-side half-bridge MOSFET.

Figure 7.3 shows the voltage across the lamp and the VS voltage when the lower filament of the lamp is removed. Figure 7.4 shows these voltages when the upper filament of the lamp is removed. In both cases, the IRS2530D will enter the Fault Mode and shut down after detecting that the crest factor exceeds 5 during the on-time of LO. Figure 7.5 shows the VS pin, inductor current, and voltage across lamp when the inductor saturates and the ballast shuts down.

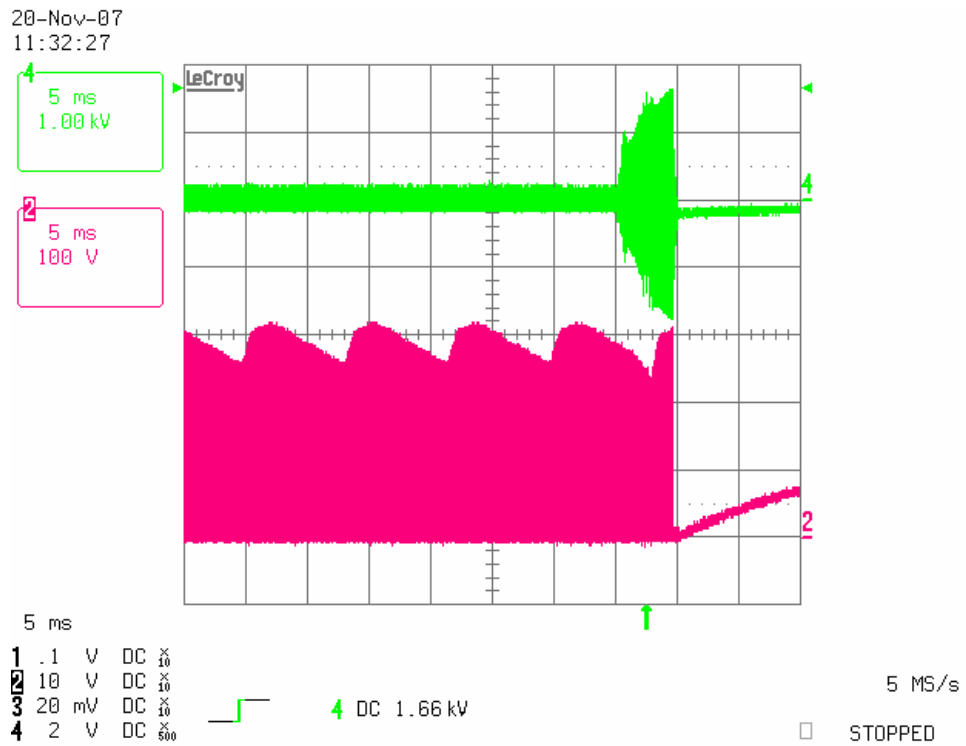

Figure 7.3: Lower filament removed: CH2 is the VS voltage, CH4 is the voltage across the lamp

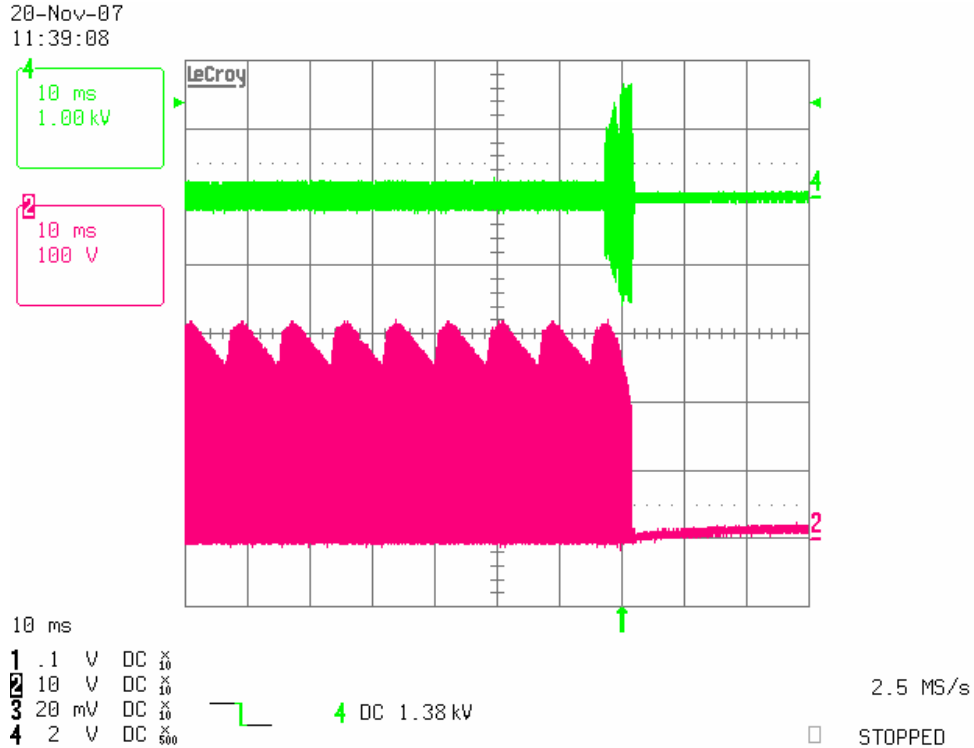

Figure 7.4: Upper filament removed: CH2 is the VS voltage, CH4 is the voltage across the lamp

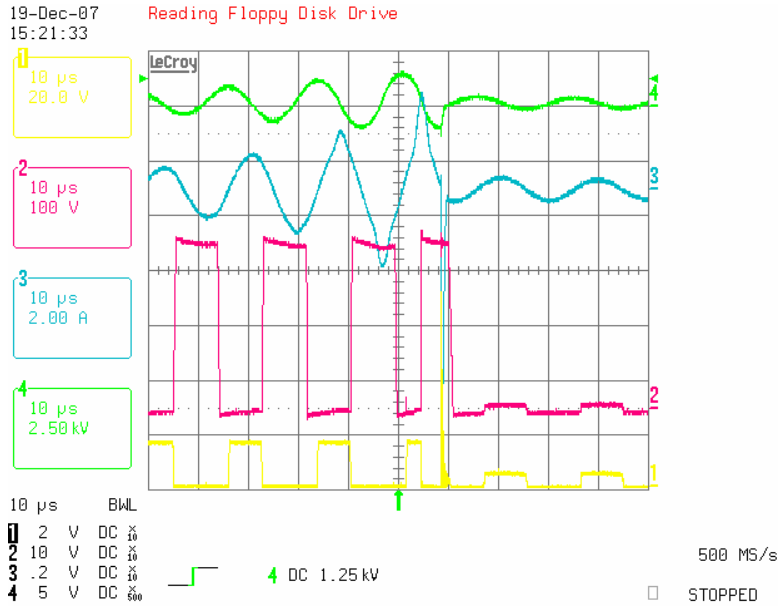

Figure 7.5: Inductor saturation: CH1 is the LO voltage, CH2 is the VS voltage, CH3 is the current through the resonant inductor, and CH4 is the voltage across the lamp

Figure 7.6 shows the VS voltage and the voltage across the lamp when the IC undergoes reset with a lamp exchange. When the lamp is removed, crest factor protection is triggered, and the IC enters the Fault mode and shuts down. Since the lamp is removed, LO pins is pulled above VLOSD+, and the IC goes to UVLO mode. When the lamp is re-inserted, the IC goes back to the Preheat / Ignition mode, and the half-bridge starts to oscillate again.

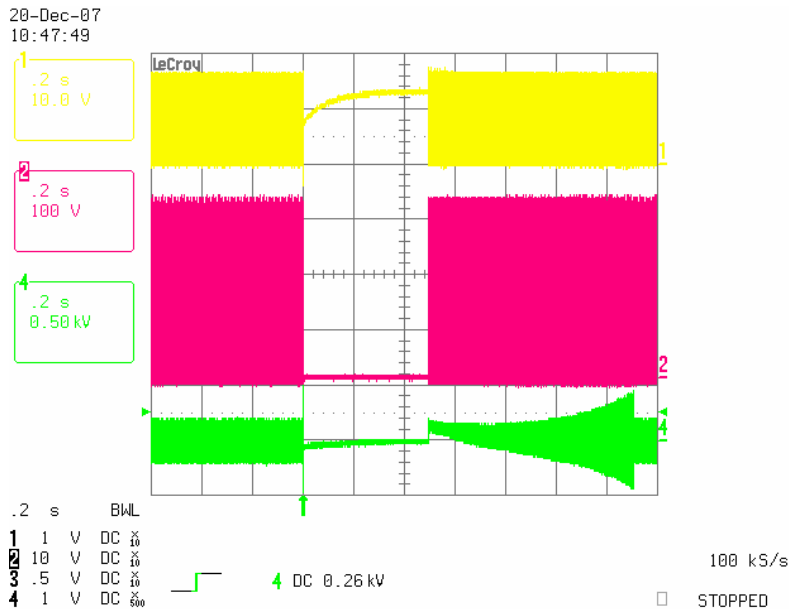

Figure 7.6: Lamp exchange: CH1 is the LO voltage, CH2 is the VS voltage, and CH4 is the voltage across the lamp

8. Ballast Design

Layout Guidelines

Proper care should be taken when laying out a PCB board to minimize noise effects due to high-frequency switching and to ensure proper functionality of the IRS2530D.

1. There should be a star point for all of the 0V returns, particularly IC1 pin 2, CVCC, CDIM, CVCO, CCPH, R7 and C5, which is then connected to the source of the lower half-bridge MOSFET(ML) via a single trace which is as short as possible. This avoids potential ground loop problems.
2. The VCC decoupling capacitor (CVCC2) should be placed as close to the IRS2530D VCC (pin 1) and COM (pin 2) as possible with the shortest possible traces.
3. Double filter at VCC (RVCC1, CVCC1, RVCC2, and CVCC2) should be utilized to filter high current spikes that can cause large voltage spikes to occur on VCC.
4. All IC programming and filter components should be placed as close as possible between their respective pins and COM (CVCO, RVCO, CCPH, CDIM, CFB, RFB).
5. Keep RCS, RFB and CFB as far away as possible from the VS node to prevent high-frequency, high-voltage switching noise from interfering with dimming feedback signal.
6. The high-side gate-drive ground (VS) should be connected to half-bridge mid-point at one connection only.
7. The anode of charge pump diode DCP1 should be connected to the power ground not the signal ground.
8. Use gate resistors (RLO, RHO) between all gate driver outputs and the gate of their respective power MOSFETs.

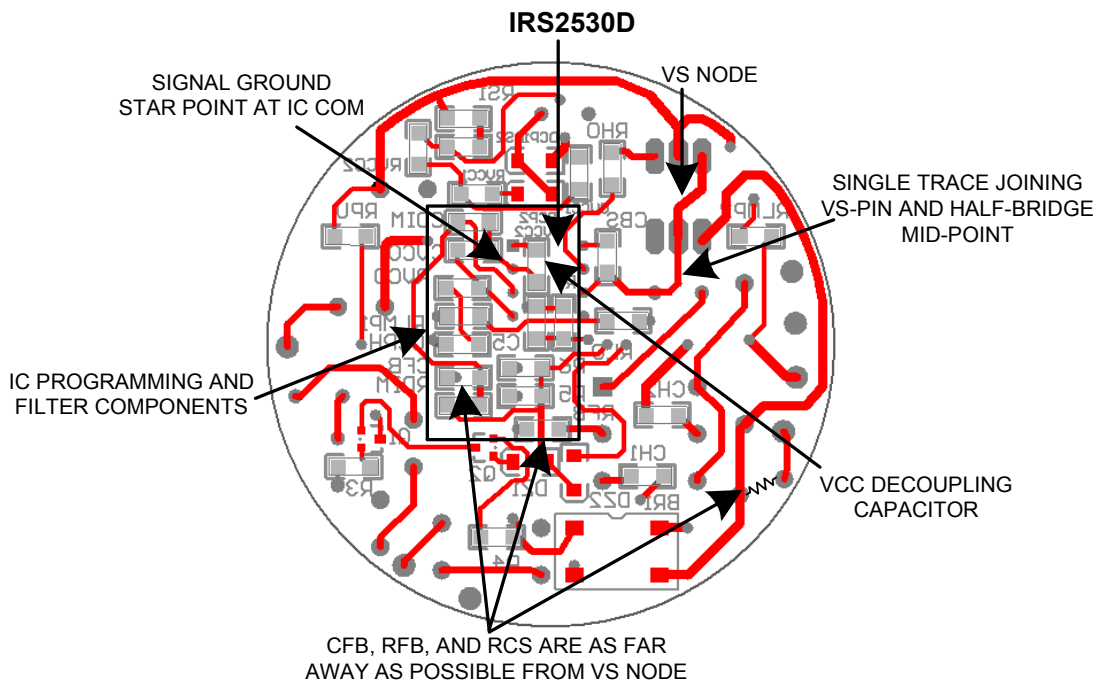

Figure 8.1: Critical traces on the bottom side of the PCB

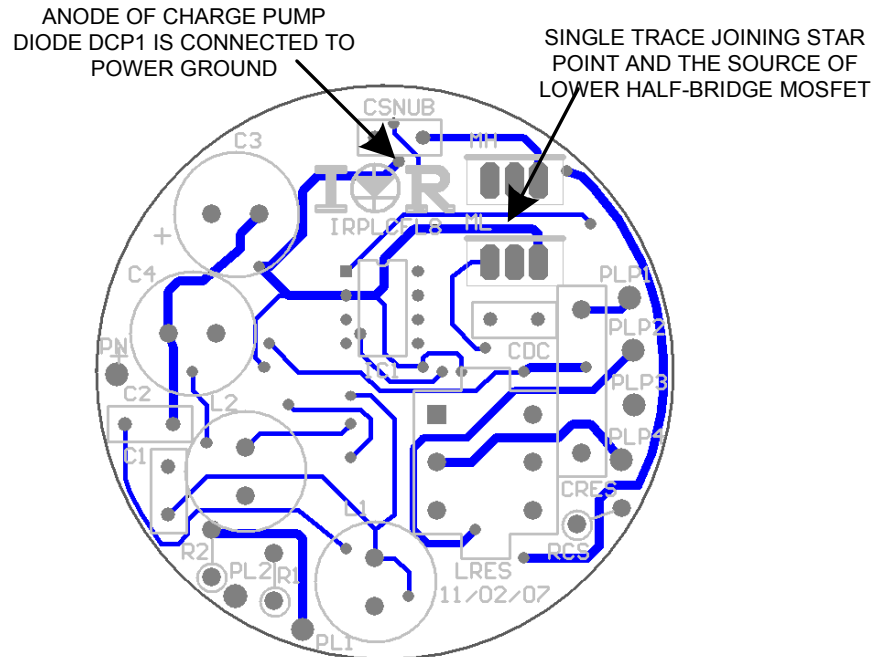

Figure 8.2: Critical traces on the top side of the PCB

Components Selection

The output inductor and capacitor values should be chosen to allow the ballast to run at maximum brightness around 40-45kHz. This will minimize losses in the inductor. For this example the *IR Ballast Designer* software * has been used to select the required preheat, ignition and run frequencies for a 32W spiral CFL lamp giving an LRES of 2.2mH and CRES of 4.7nF.

Output Inductor Design

The output inductor LRES should be designed to allow a high peak ignition current without saturating. This is important as the IRS2530D shutdown will be triggered if the inductor saturates. The ignition current depends on the type of lamp being used and must be kept to a minimum by ensuring the preheat is sufficient. To minimize losses in the inductor multi-stranded wire should be used in combination with Ferrite cores of adequate quality. The best approach to design is to wind as many turns as possible of multi-stranded wire and have the largest gap possible to achieve the correct inductance. This will produce the highest available peak current before saturating the inductor. It is important to be aware that when the cores are hot the saturation point and hence the peak current for the inductor will be lower therefore a poorly designed inductor may result in the ballast shutting down during an attempted hot re-strike.

The inductor design process can be greatly simplified by using the *Ballast Designer* software produced by I.R. For this application and lamp size it is recommended to fix the core size to EF20.

Lamp Preheating

The lamp must be sufficiently preheated before ignition. The correct preheat current can be determined from published data or from International Rectifiers *Ballast Designer* software.

The preheat time can be set by adjusting the value of CPH. As a general rule the lamp filament should glow red before ignition. If preheat is insufficient the ballast is likely to shutdown during ignition because the output inductor will be unable to operate at the high current required. The number of turns in the auxiliary cathode windings of the output inductor LRES should be chosen to provide sufficient preheat. In designs for ballasts with integral lamps the shutdown pin can be grounded so that the inductor may saturate without shutting down the circuit.

The lamp filament (Cathode) resistance over the range of dimming levels should be between 3 and 5.5 times the resistance when cold. A simple method for determining the hot resistance is to first connect one cathode to a DC power supply via an ammeter and slowly increase the voltage from zero, noting the current at 1V intervals. This should be done until the cathode can be seen to be glowing red. When this occurs the voltage should not be increased further in order to prevent possible cathode damage. The resistance can then be calculated for each voltage and hence the acceptable voltage range can be found to comply with the 3 to 5.5 times cold resistance, which can be easily measured with a digital multi-meter (DMM).

Then when the ballast is being run a true RMS digital voltmeter can be connected across one cathode and the voltage can be observed at maximum and minimum brightness. The cathode voltage increases as the ballast is dimmed. The values of CH1 and CH2 will control how much it increases by, reducing the capacitance will reduce the amount by which the voltage rises. The values should be chosen to prevent the voltage exceeding the upper limit at minimum output.

It is important to consider that using additional windings on the inductor to provide cathode heating means that power is now being transferred through the core and consequently the core losses will increase and hence the core operating temperature. The core will reach its highest operating temperature when the ballast is running at minimum brightness.

9. Bill of Materials

| Item # | Qty | Manufacturer | Part Number | Description | Reference |
|--------|-----|----------------------------|--------------------|--|-------------------|
| 1 | 1 | International Rectifier | IRS2530D | Ballast Controller | IC1 |
| 2 | 2 | International Rectifier | IRF730 | MOSFET | MH,ML |
| 3 | 2 | Fairchild | MMBTA42 | Transistor 300V, SOT-23 | Q1,Q2 |
| 4 | 1 | Diodes Inc | ZMM5266B-7 | Zener Diode 68V | DZ1 |
| 5 | 1 | Diodes Inc | ZMM5230B-7 | Zener Diode, 4V7 | DZ2 |
| 6 | 2 | Diodes Inc | LL4148-13 | Small Signal Diode SMD | DCP1, DCP2 |
| 7 | 1 | Fairchild | DF10S | Bridge SMD | BR1 |
| 8 | 2 | Renco | RL-5480-3-2700 | Filter Inductor | L1,L2 |
| 9 | 1 | Vogt | IL 070 503 11 02 | Inductor 2.2mH EF20 | LRES |
| 10 | 2 | Panasonic-ECG | ECQ-E2104KB | Capacitor 100nF, 250V | C1,2 |
| 11 | 2 | Panasonic-ECG | ECA-2EHG330 | Capacitor, 33uF 250V 105C Electrolytic | C3,4 |
| 12 | 1 | Panasonic-ECG | ECJ-3YX1C106K | Capacitor 10u, 16V, 1206 | C5 |
| 13 | 2 | Panasonic-ECG | ECJ-3YB1C225K | Capacitor 2u2, 16V, 1206 | CVCC1, CVCC2 |
| 14 | 1 | Panasonic-ECG | ECJ-3YC2D102J | Capacitor 1nF, 200V, 1206 | CDIM |
| 15 | 1 | Panasonic-ECG | ECJ-3VB1C334K | Capacitor 0.33uF, 16V, 1206 | CCPH |
| 16 | 1 | Panasonic-ECG | ECJ-3VC2A222J | Capacitor 2n2, 100V, 1206 | CVCO |
| 17 | 2 | Panasonic-ECG | ECJ-3VB1H104K | Capacitor 100nF, 50V, 1206 | CFB, CBS |
| 18 | 2 | Panasonic-ECG | ECJ-3YB1H224K | Capacitor 220nF, 50V, 1206 | CH1, CH2 |
| 19 | 1 | Panasonic-ECG | ECK-A3A102KBP | Capacitor 1nF, 1kV, Ceramic | CSNUB |
| 20 | 1 | Wima | MKS2 Series | Capacitor 47nF, 400V | CDC |
| 21 | 1 | Wima | MKP10 Series | Capacitor 4.7nF, 1600V, 15mm, Pulse | CRES |
| 22 | 2 | Yageo | CFR-50JB-5R6 | 5.6R 1/2W Axial | R1, R2 |
| 23 | 4 | Panasonic-ECG | ERJ-8GEYJ105V | Resistor, 1M, 0.25W, 1206 | R3, R4, R6, RLMP2 |
| 24 | 1 | Panasonic-ECG | ERJ-8GEYJ334V | Resistor, 330K, 0.25W, 1206 | R5 |
| 25 | 1 | Panasonic-ECJ | ERJ-8GEYJ202V | Resistor, 2K, 0.25W 1206 | R7 |
| 26 | 1 | Panasonic-ECJ | ERJ-8GEYJ154V | Resistor, 150K, 0.25W, 1206 | RPU |
| 27 | 2 | Panasonic-ECJ | ERJ-8GEYJ100V | Resistor, 10R, 0.25W, 1206 | RVCC1, RVCC2 |
| 28 | 1 | Panasonic-ECJ | ERJ-8GEYJ103V | Resistor, 10K, 0.25W, 1206 | RDIM |
| 29 | 1 | Panasonic-ECJ | ERJ-8GEYJ152V | Resistor, 1K5, 0.25W, 1206 | RVCO |
| 30 | 1 | Panasonic-ECJ | ERJ-8GEYJ102V | Resistor, 1K, 0.25W, 1206 | RFB |
| 31 | 2 | Panasonic-ECJ | ERJ-8GEYJ220V | Resistor, 22R, 0.25W, 1206 | RHO, RLO |
| 32 | 1 | Panasonic-ECJ | ERJ-8GEYJ474V | Resistor, 470K, 0.25W, 1206 | RLMP1 |
| 33 | 2 | Panasonic-ECJ | ERJ-8GEYJ274V | Resistor, 270K, 0.25W, 1206 | RS1, RS2 |
| 34 | 1 | Phoenix Passive Components | 5073NW15R00J12 AFX | Resistor, 15R, 1W, Axial | RCS |

TABLE 9.1: IRPLCFL8U Bill of Materials.

10. IRPLCFL8U PCB Layout

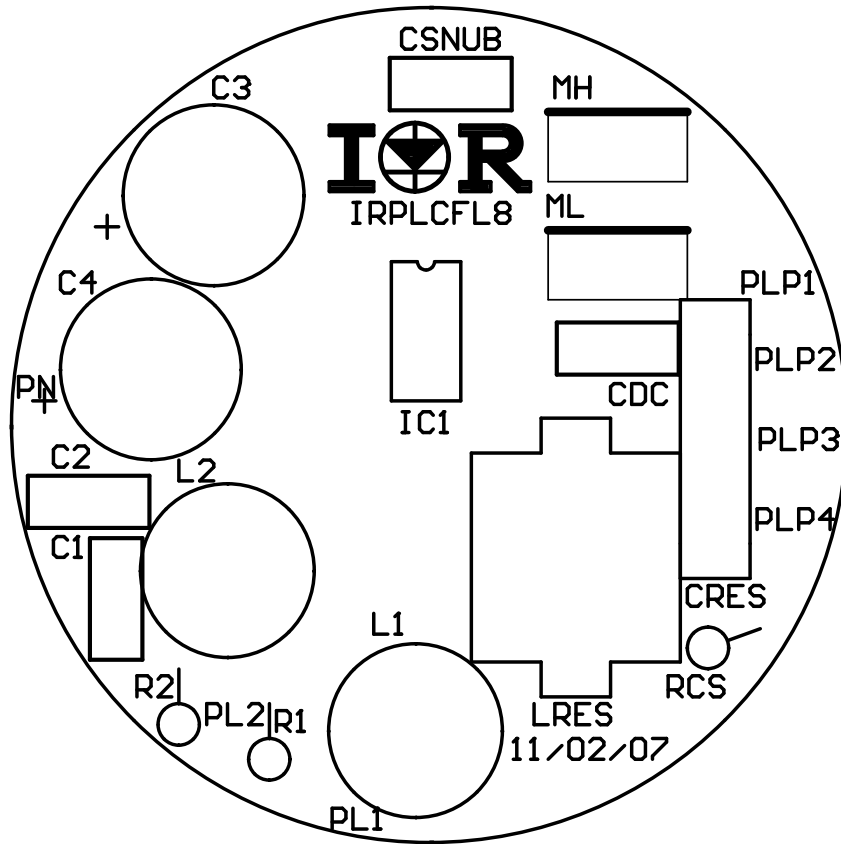

Top Assembly

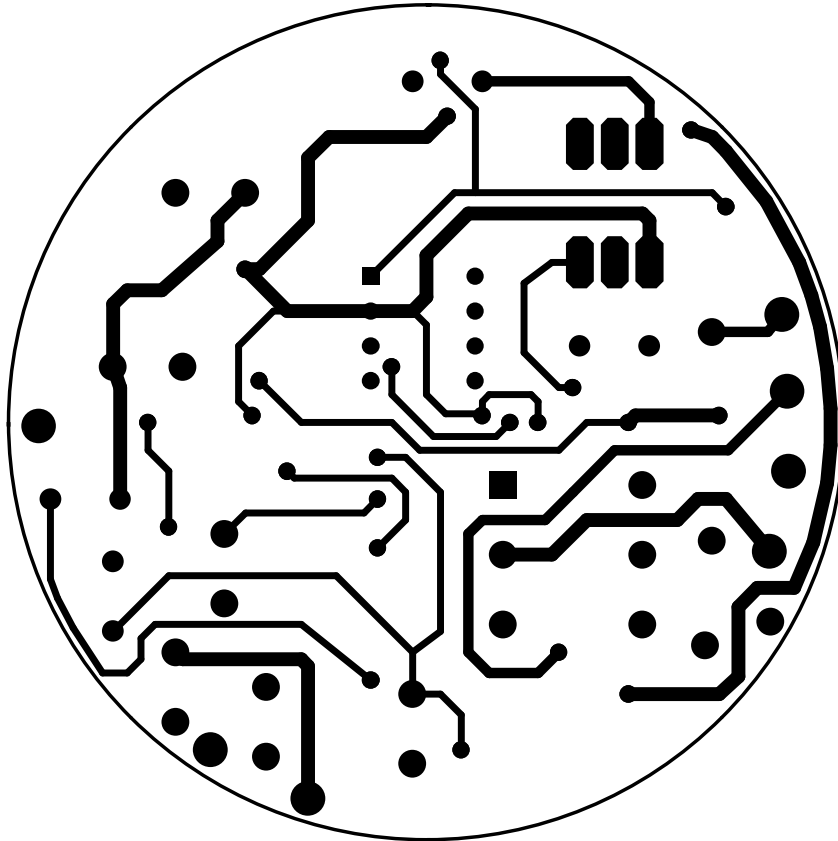

Top Copper

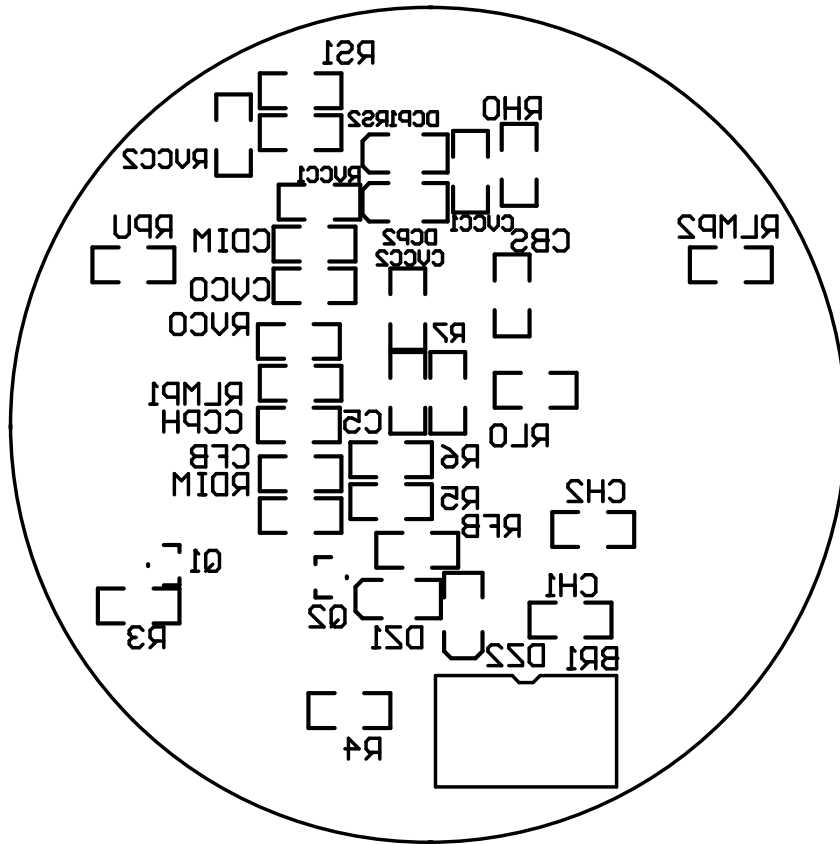

Bottom Assembly

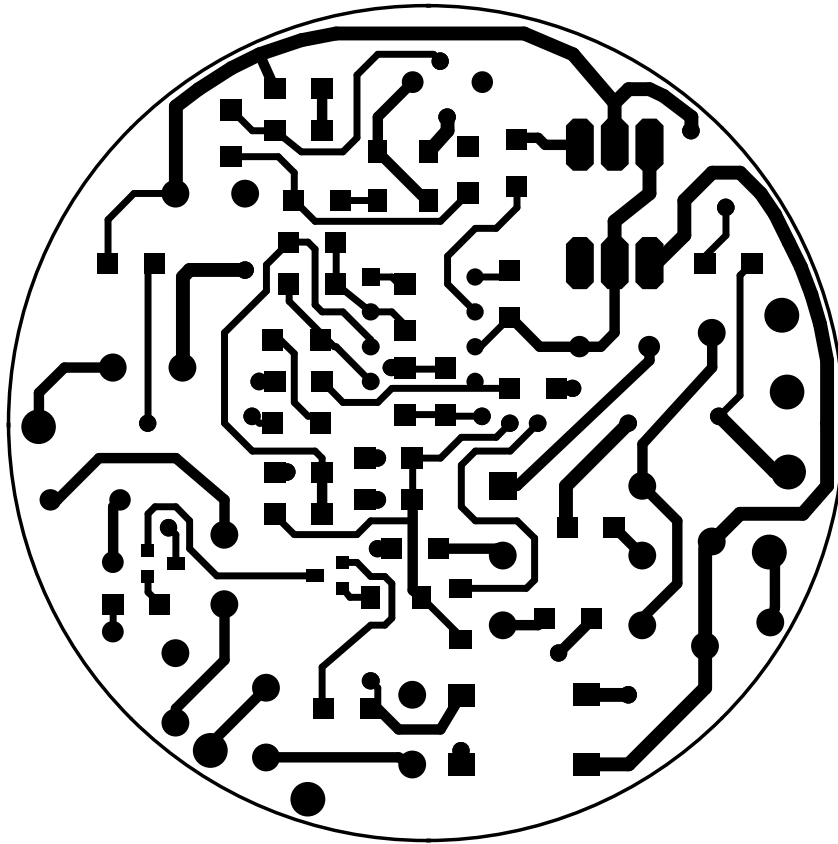

Bottom Copper

11. Inductor Specifications

Vogt # IL 070 503 11 02
BI Technologies # HM00-07544



INDUCTOR SPECIFICATION

CORE SIZE

GAP LENGTH mm

CORE MATERIAL

NOMINAL INDUCTANCE mH

TEST TEMPERATURE C

| WINDING | START PIN | FINISH PIN | TURNS | WIRE DIAMETER (mm) |
|---------|-----------|------------|-------|----------------------|
| MAIN | 1 | 6 | 240* | 10/ 38 Multistranded |
| CATHODE | 2 | 5 | 5.5 | 26 awg insulated |
| CATHODE | 3 | 4 | 5.5 | 26 awg insulated |

PHYSICAL LAYOUT
(Vertical6- Pin Bobbin)

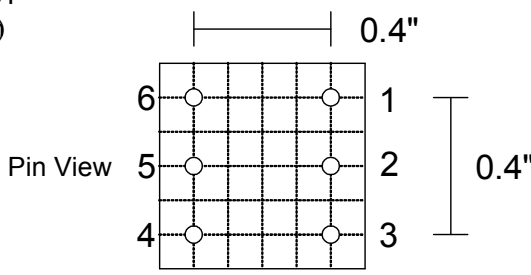

TEST TEST TEMPERATURE C

MAIN WINDING INDUCTANCE mH

* Adjust turns for specified Inductance mH