



Approved by:

Checked by:

Issued by:

SPECIFICATION

PRODUCT: SAW FILTER

MODEL: HF93802D (K9352D) SIP5D

HOPE MICROELECTRONICS CO., LIMITED

1. Construction

1.1 Dimension and materials

Type : F93802D

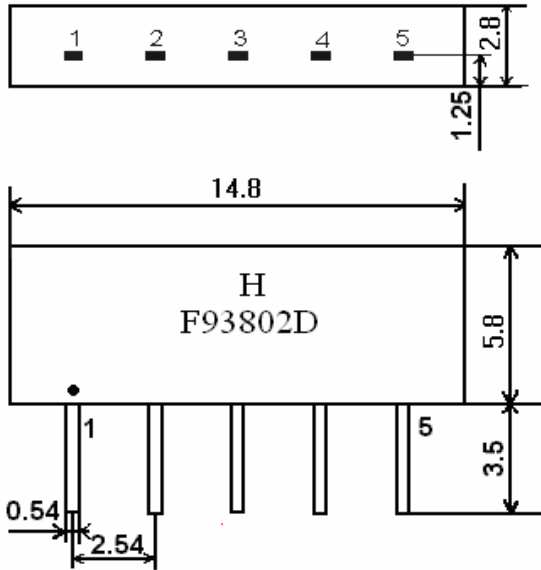

Unit : mm

- 1 Input
- 2 Input ground
- 3 Chip carrier - ground
- 4 Output
- 5 Output

1.2. Circuit construction, measurement circuit

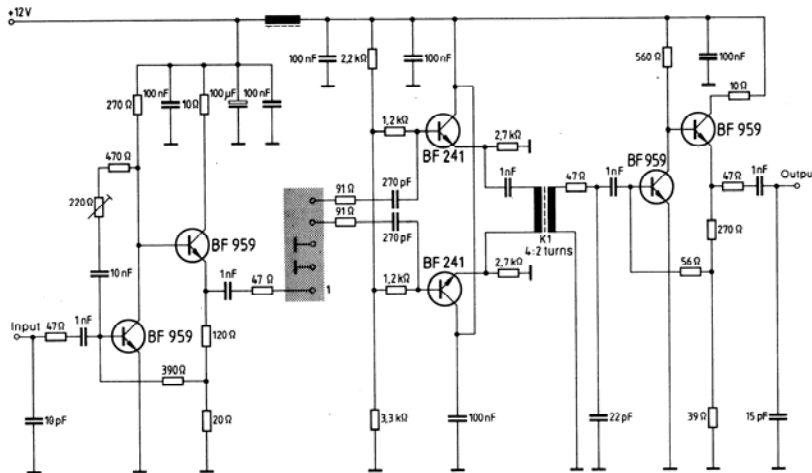

Test circuit for SIP-5 filter
Input impedance of the symmetrical post-amplifier: 2 kΩ in parallel with 3 pF

2.Characteristics

Standard atmospheric conditions

Unless otherwise specified , the standard range of atmospheric conditions for making measurements and tests is as follows;

- Ambient temperature : 15°C to 35°C
- Relative humidity : 25% to 85%
- Air pressure : 86kPa to 106kPa

Operating temperature rang

Operating temperature rang is the rang of ambient temperatures in which the filter can be operated continuously. $-10^{\circ}\text{C} \sim +60^{\circ}\text{C}$

Storage temperature rang

Storage temperature rang is the rang of ambient temperatures at which the filter can be stored without damage.

Conditions are as specified elsewhere in these specifications. $-40^{\circ}\text{C} \sim +70^{\circ}\text{C}$

Reference temperature $+25^{\circ}\text{C}$

2.1 Maximum Rating

DC voltage	VDC	12	V	Between any terminals
AC voltage	Vpp	10	V	Between any terminals

2.2 Electrical Characteristics

Source impedance $Z_s=50\ \Omega$

Load impedance $Z_L=2\text{k}\ \Omega //3\text{pF}$ $T_A=25^{\circ}\text{C}$

Item	Freq	min	typ	max	
Insertion attenuation Reference level	31.50MHz	11.9	13.9	15.9	dB
Relative attenuation	32.50MHz	-1.3	-0.1	1.1	dB
	33.50MHz	-1.0	0.2	1.4	dB
	38.00MHz	40.0	50.0	-	dB
	30.00MHz	40.0	55.0	-	dB
	39.50MHz	40.0	52.0	-	dB
	40.00MHz	40.0	48.0	-	dB
	40.50MHz	40.0	55.0	-	dB
Sidelobe	25.00~30.00MHz	35.0	42.0	-	dB
	38.00~45.00MHz	36.0	45.0	-	dB
Temperature coefficient		-72			ppm/k

2.3 Environmental Performance Characteristics

Item Test condition	Allowable change of absolute Level at center frequency(dB)
High temperature test 70°C 1000H	< 1.0
Low temperature test -40°C 1000H	< 1.0
Humidity test 40°C 90-95% 1000H	< 1.0
Thermal shock $-20^{\circ}\text{C} \rightleftharpoons 25^{\circ}\text{C} \rightleftharpoons 80^{\circ}\text{C}$ 20 cycle	< 1.0

30M 10M 30M	
Solder temperature test Sold temp.260°C for 10 sec.	< 1.0
Soldering Immerse the pins melt solder at 260°C+5/-0°C for 5 sec.	More then 95% of total area of the pins should be covered with solder

2.4 Mechanical Test

Item Test condition	Allowable change of absolute Level at center frequency(dB)
Vibration test 600-3300rpm amplitude 1.5mm 3 directions 2 H each	<1.0
Drop test On maple plate from 1 m high 3 times	<1.0
Lead pull test Pull with 1 kg force for 30 seconds	<1.0
Lead bend test 90° bending with 500g weigh 2 times	<1.0

2.5 Voltage Discharge Test

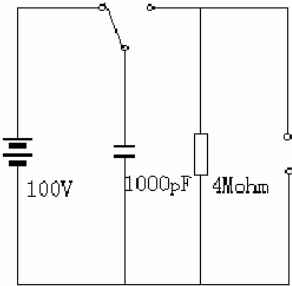
Item Test condition	Allowable change of absolute Level at center frequency(dB)
Surge test Between any two electrode 	<1.0

2.6 Frequency response:

CH1 S21 log MAG 10 dB/ REF -13.9 dB 2: -.2286 dB

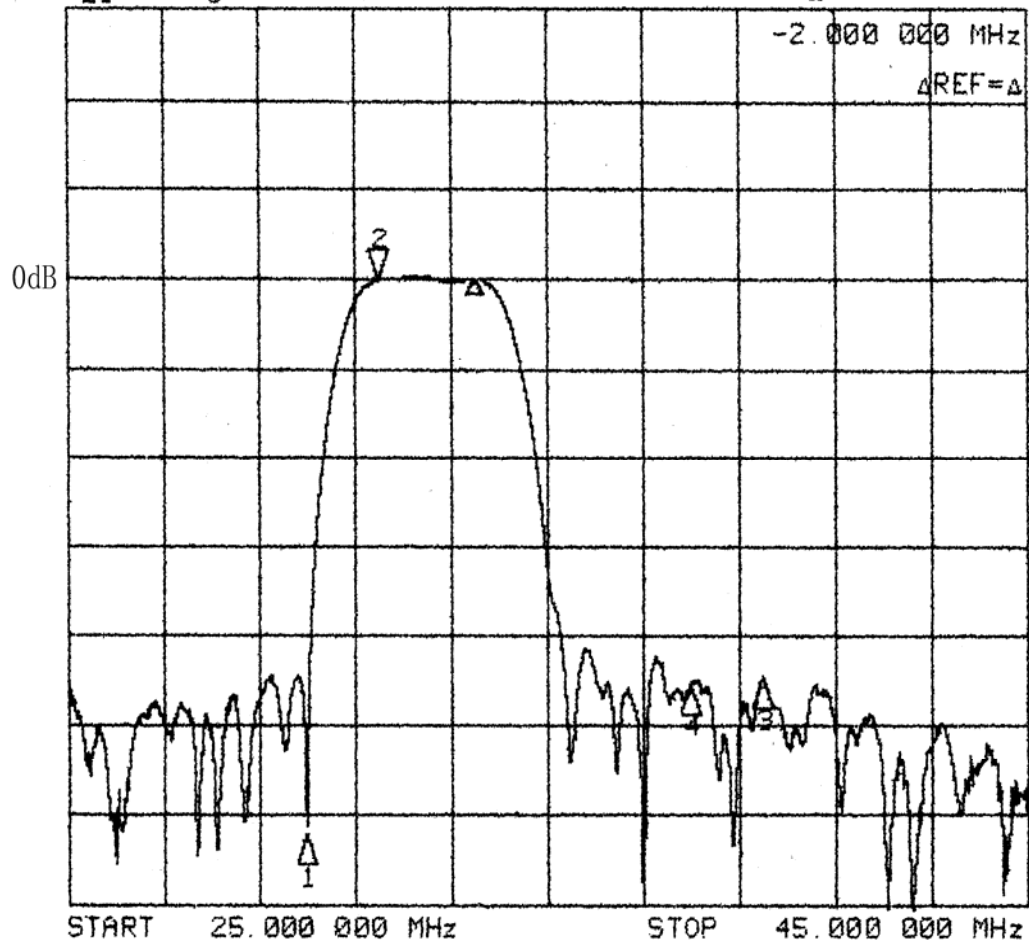

CH1 S21 delay 30 ns/ REF 1.194 μ s 2: 1.095 μ s
 CH2 S21 log MAG 1 dB/ REF -13.9 dB 2: -13.788 dB

