

Gunter Semiconductor GmbH

GFC310

N Channel Power MOSFET

Chip Specification

General Description:

- * Advanced Process Technology
- * Dynamic dV/dt Rating
- * **150°C Operating Temperature**
- * **Fast Switching**
- * **Fully Avalanche Rated**

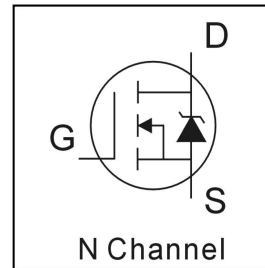

Mechanical Data:

D5	
Dimension	1.96mm x 2.68mm
Thickness:	400 μm
Metallization:	
Top :	Al
Backside :	CrNiAg / Au
Suggested Bonding Conditions:	
Die Mounting:	Solder Perform
	95/5 PbSn or 92.5./2.5/5 PbAgIn
Source Bonding Wir	5 mil Al

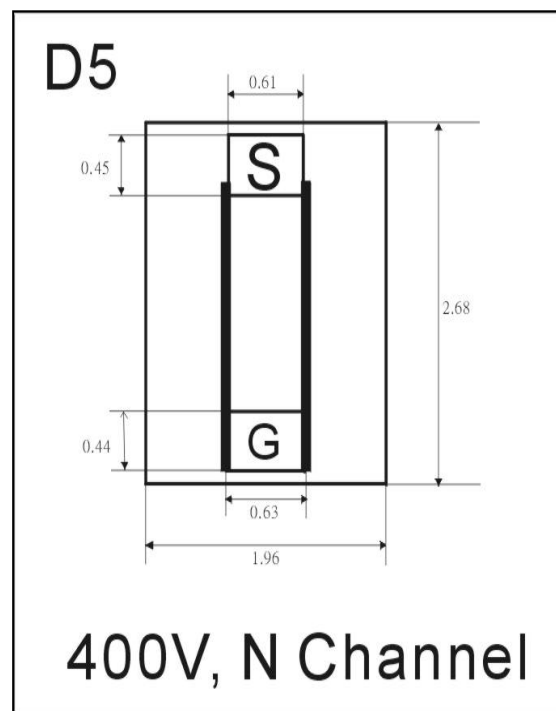

Absolute Maximum Rating

@Ta=25°C

Characteristics	Symbol	Limit	Unit	Test Conditions
Drain-to-Source Breakdown Voltage	V(BR)DSS	400	V	VGS=0V, ID=250μA
Static Drain-to - Source On-resistance	RDS(ON)	3.6	Ω	VGS=10V, ID=1A
Continuous Drain current (in target package)	ID@25°C	2	A	VGS=10V
Continuous Drain current (in target package)	ID@100°C	1.3	A	VGS=10V
Operation Junction	Tj	-55~150	°C	
Storage Temperature	TSTR	-55~150	°C	

Target Device: IRF710

TO-220AB

Pd

36

W

@Tc=25°C

