



Low-Power, Adjustable Battery Monitors with Hysteresis and Integrated μP Reset

General Description

The MAX6846–MAX6849 are a family of ultra-low-power battery monitors with integrated microprocessor (μP) supervisors. The user-adjustable battery monitors are offered with single or dual low-battery output options that can be used to signal when the battery is OK (enabling full system operation), when the battery is low (for low-power system operation), and when the battery is dead (to disable system operation). These devices also have an independent μP supervisor that monitors V_{CC} and provides an active-low reset output. A manual reset function is available to reset the μP with a pushbutton.

The MAX6846–MAX6849 are ideal for single-cell lithium-ion (Li+) or multicell alkaline/NiCd/NiMH applications. When the battery voltage drops below each adjusted low threshold, the low-battery outputs are asserted to alert the system. When the voltage rises above the adjusted high thresholds, the outputs are deasserted after a 150ms minimum timeout period, ensuring the voltages have stabilized before power circuitry is activated or providing microprocessor reset timing.

These devices have user-adjustable battery threshold voltages, providing a wide hysteresis range to prevent chattering that can result due to battery recovery after load removal. Single low-battery outputs are supplied by the MAX6846/MAX6847 and dual low-battery outputs are supplied by the MAX6848/MAX6849. All battery monitors have open-drain low-battery outputs.

The MAX6846–MAX6849 monitor system voltages (V_{CC}) from 1.8V to 3.3V with seven fixed reset threshold options. Each device is offered with two minimum reset timeout periods of 150ms or 1200ms. The MAX6846/MAX6848 are offered with an open-drain RESET output and the MAX6847/MAX6849 are offered with a push-pull RESET output.

The MAX6846–MAX6849 are offered in a SOT23 package and are fully specified over a -40°C to $+85^{\circ}\text{C}$ temperature range.

Applications

Battery-Powered Systems (Single-Cell Li+ or Multicell NiMH, NiCd, Alkaline)

Cell Phones/Cordless Phones

Portable Medical Devices

Digital Cameras

Pagers

PDA's

MP3 Players

Electronic Toys

Features

- ◆ User-Adjustable Thresholds for Monitoring Single-Cell Li+ or Multicell Alkaline/NiCd/NiMH Applications
- ◆ Single and Dual Low-Battery Output Options
- ◆ Independent μP Reset with Manual Reset
- ◆ Factory-Set Reset Thresholds for Monitoring 1.8V to 3.3V Systems
- ◆ Available with 150ms (min) or 1.2s (min) V_{CC} Reset Timeout Period Options
- ◆ 150ms (min) LBO Timeout Period
- ◆ Immune to Short-Battery Voltage Transients
- ◆ Low Current (2.5 μA , typ at 3.6V)
- ◆ -40°C to $+85^{\circ}\text{C}$ Operating Temperature Range
- ◆ Small 8-Pin SOT23 Packages

Ordering Information

PART	TEMP RANGE	PIN-PACKAGE
MAX6846KA_D_-T	-40°C to $+85^{\circ}\text{C}$	8 SOT23-8
MAX6847KA_D_-T	-40°C to $+85^{\circ}\text{C}$	8 SOT23-8
MAX6848KA_D_-T	-40°C to $+85^{\circ}\text{C}$	8 SOT23-8
MAX6849KA_D_-T	-40°C to $+85^{\circ}\text{C}$	8 SOT23-8

Note: The first “_” is the V_{CC} reset threshold level, suffix found in Table 1. The “_” after the D is a placeholder for the reset timeout period suffix found in Table 2. All devices are available in tape-and-reel only. There is a 2500 piece minimum order increment for standard versions (see Standard Versions table). Sample stock is typically held on standard versions only. Non-standard versions require a minimum order increment of 10,000 pieces. Contact factory for availability.

Devices are available in both leaded and lead-free packaging. Specify lead-free by replacing “-T” with “+T” when ordering.

Pin Configurations

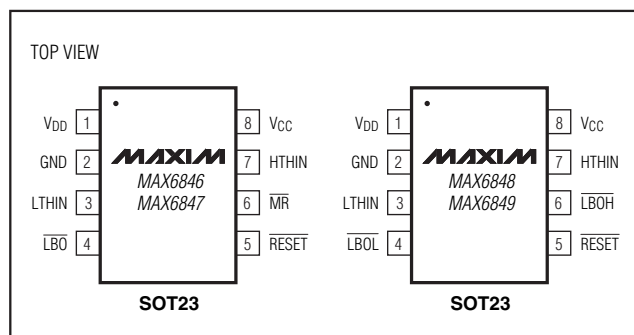

Low-Power, Adjustable Battery Monitors with Hysteresis and Integrated μP Reset

ABSOLUTE MAXIMUM RATINGS

V_{DD} , V_{CC} to GND	-0.3V to +6V*
Open-Drain $\overline{\text{LBO}}$, $\overline{\text{LBOH}}$, $\overline{\text{LBOL}}$ to GND	-0.3V to +6V*
Open-Drain $\overline{\text{RESET}}$ to GND	-0.3V to +6V*
Push-Pull $\overline{\text{RESET}}$ to GND	-0.3V to ($V_{\text{CC}} + 0.3\text{V}$)
HTHIN, LTHIN to GND	-0.3V to ($V_{\text{DD}} + 0.3\text{V}$)
$\overline{\text{MR}}$ to GND	-0.3V to ($V_{\text{CC}} + 0.3\text{V}$)
Input/Output Current, All Pins	20mA

*Applying 7V for a duration of 1ms does not damage the device.

Continuous Power Dissipation ($T_{\text{A}} = +70^{\circ}\text{C}$)	8-Pin SOT23 (derate 8.9mW/ $^{\circ}\text{C}$ above $+70^{\circ}\text{C}$).....	714mW
Operating Temperature Range		-40°C to $+85^{\circ}\text{C}$
Junction Temperature		$+150^{\circ}\text{C}$
Storage Temperature Range		-65°C to $+150^{\circ}\text{C}$
Lead Temperature (soldering, 10s)		$+300^{\circ}\text{C}$

Stresses beyond those listed under "Absolute Maximum Ratings" may cause permanent damage to the device. These are stress ratings only, and functional operation of the device at these or any other conditions beyond those indicated in the operational sections of the specifications is not implied. Exposure to absolute maximum rating conditions for extended periods may affect device reliability.

ELECTRICAL CHARACTERISTICS

($V_{\text{DD}} = 1.6\text{V}$ to 5.5V , $V_{\text{CC}} = 1.2\text{V}$ to 5.5V , $T_{\text{A}} = -40^{\circ}\text{C}$ to $+85^{\circ}\text{C}$, unless otherwise specified. Typical values are at $T_{\text{A}} = +25^{\circ}\text{C}$.) (Note 1)

PARAMETER	SYMBOL	CONDITIONS	MIN	TYP	MAX	UNITS
V_{DD} Operating Voltage Range	V_{DD}		1.6		5.5	V
V_{CC} Operating Voltage Range	V_{CC}	$T_{\text{A}} = 0^{\circ}\text{C}$ to $+85^{\circ}\text{C}$	1.0		5.5	V
		$T_{\text{A}} = -40^{\circ}\text{C}$ to $+85^{\circ}\text{C}$	1.2		5.5	
$V_{\text{CC}} + V_{\text{DD}}$ Supply Current	$I_{\text{CC}} + I_{\text{DD}}$	$V_{\text{DD}} = 3.6\text{V}$, $V_{\text{CC}} = 3.3\text{V}$, no load (Note 2)		2.5	7	μA
MAX6846/MAX6847 V_{DD} THRESHOLDS						
HTHIN Threshold	V_{HTH}	HTHIN rising, $\overline{\text{LBO}}$ is deasserted when HTHIN rises above V_{HTH}	600	615	630	mV
LTHIN Threshold	V_{LTH}	LTHIN falling, $\overline{\text{LBO}}$ is asserted when LTHIN falls below V_{LTH}	600	615	630	mV
MAX6848/MAX6849 V_{DD} THRESHOLDS						
HTHIN+ Threshold	$V_{\text{HTH+}}$	HTHIN rising, $\overline{\text{LBOH}}$ is deasserted when HTHIN rises above $V_{\text{HTH+}}$	600	615	630	mV
HTHIN- Threshold	$V_{\text{HTH-}}$	HTHIN falling, $\overline{\text{LBOH}}$ is asserted when HTHIN falls below $V_{\text{HTH-}}$	567	582	597	mV
LTHIN+ Threshold	$V_{\text{LTH+}}$	LTHIN rising, $\overline{\text{LBOL}}$ is deasserted when LTHIN rises above $V_{\text{LTH+}}$	600	615	630	mV
LTHIN- Threshold	$V_{\text{LTH-}}$	LTHIN falling, $\overline{\text{LBOL}}$ is asserted when LTHIN falls below $V_{\text{LTH-}}$	567	582	597	mV
MAX6846-MAX6849						
HTHIN/LTHIN Leakage Current	I_{LKG}	V_{HTHIN} or $V_{\text{LTHIN}} \geq 400\text{mV}$			20	nA
$\overline{\text{LBO}}$, $\overline{\text{LBOL}}$, $\overline{\text{LBOH}}$ Timeout Period	t_{LBOP}	HTHIN/LTHIN rising above threshold	150	225	300	ms
$\overline{\text{LBO}}$, $\overline{\text{LBOL}}$, $\overline{\text{LBOH}}$ Delay Time	t_{LBOD}	HTHIN/LTHIN falling below threshold		100		μs
$\overline{\text{LBO}}$, $\overline{\text{LBOL}}$, $\overline{\text{LBOH}}$ Output Low	V_{OL}	$(V_{\text{DD}} \text{ or } V_{\text{CC}}) \geq 1.2\text{V}$, $I_{\text{SINK}} = 50\mu\text{A}$, asserted low			0.3	V
		$(V_{\text{DD}} \text{ or } V_{\text{CC}}) \geq 1.6\text{V}$, $I_{\text{SINK}} = 100\mu\text{A}$, asserted low			0.3	
		$(V_{\text{DD}} \text{ or } V_{\text{CC}}) \geq 2.7\text{V}$, $I_{\text{SINK}} = 1.2\text{mA}$, asserted low			0.3	
		$(V_{\text{DD}} \text{ or } V_{\text{CC}}) \geq 4.5\text{V}$, $I_{\text{SINK}} = 3.2\text{mA}$, asserted low			0.3	

Low-Power, Adjustable Battery Monitors with Hysteresis and Integrated μP Reset

MAX6846-MAX6849

ELECTRICAL CHARACTERISTICS (continued)

($V_{DD} = 1.6\text{V}$ to 5.5V , $V_{CC} = 1.2\text{V}$ to 5.5V , $T_A = -40^\circ\text{C}$ to $+85^\circ\text{C}$, unless otherwise specified. Typical values are at $T_A = +25^\circ\text{C}$.) (Note 1)

PARAMETER	SYMBOL	CONDITIONS	MIN	TYP	MAX	UNITS
$\overline{\text{LBO}}$, $\overline{\text{LBOL}}$, $\overline{\text{LBOH}}$ Output Open-Drain Leakage Current		Output deasserted			500	nA
V_{CC} Reset Threshold	V_{TH}	MAX68_ ___ T	3.000	3.075	3.150	V
		MAX68_ ___ S	2.850	2.925	3.000	
		MAX68_ ___ R	2.550	2.625	2.700	
		MAX68_ ___ Z	2.250	2.313	2.375	
		MAX68_ ___ Y	2.125	2.188	2.250	
		MAX68_ ___ W	1.620	1.665	1.710	
		MAX68_ ___ V	1.530	1.575	1.620	
V_{CC} Reset Hysteresis				0.3		%
V_{CC} to $\overline{\text{RESET}}$ Delay	t_{RD}	V_{CC} falling at $10\text{mV}/\mu\text{s}$ from $(V_{TH} + 100\text{mV})$ to $(V_{TH} - 100\text{mV})$		50		μs
V_{CC} to $\overline{\text{RESET}}$ Timeout Period	t_{RP}	MAX68_ ___ D3	150	225	300	ms
		MAX68_ ___ D7	1200	1800	2400	
$\overline{\text{MR}}$ Input Voltage	V_{IL}				$0.3 \times V_{CC}$	V
	V_{IH}		$0.7 \times V_{CC}$			
$\overline{\text{MR}}$ Minimum Pulse Width	t_{MPW}		1			μs
$\overline{\text{MR}}$ Glitch Rejection				100		ns
$\overline{\text{MR}}$ to $\overline{\text{RESET}}$ Delay				200		ns
$\overline{\text{MR}}$ Reset Timeout Period	t_{MRP}		150	225	300	ms
$\overline{\text{MR}}$ Pullup Resistance		$\overline{\text{MR}}$ to V_{CC}	750	1500	2250	Ω
$\overline{\text{MR}}$ Rising Debounce Period	t_{DEB}	(Note 3)	150	225	300	ms
$\overline{\text{RESET}}$ Output High (Push-Pull)	V_{OH}	$V_{CC} \geq 1.53\text{V}$, $I_{SOURCE} = 100\mu\text{A}$, $\overline{\text{RESET}}$ deasserted	$0.8 \times V_{CC}$			V
		$V_{CC} \geq 2.55\text{V}$, $I_{SOURCE} = 500\mu\text{A}$, $\overline{\text{RESET}}$ deasserted	$0.8 \times V_{CC}$			
$\overline{\text{RESET}}$ Output Low	V_{OL}	$V_{CC} \geq 1.0\text{V}$, $I_{SINK} = 50\mu\text{A}$, $\overline{\text{RESET}}$ asserted			0.3	V
		$V_{CC} \geq 1.2\text{V}$, $I_{SINK} = 100\mu\text{A}$, $\overline{\text{RESET}}$ asserted			0.3	
		$V_{CC} \geq 2.12\text{V}$, $I_{SINK} = 1.2\text{mA}$, $\overline{\text{RESET}}$ asserted			0.3	
$\overline{\text{RESET}}$ Output Leakage Current (Open Drain)		$\overline{\text{RESET}}$ deasserted			500	nA

Note 1: Production testing done at $T_A = +25^\circ\text{C}$; limits over temperature guaranteed by design only.

Note 2: The device is powered up by the highest voltage between V_{DD} and V_{CC} .

Note 3: $\overline{\text{MR}}$ input ignores falling input pulses, which occur within the $\overline{\text{MR}}$ debounce period (t_{DEB}) after a valid $\overline{\text{MR}}$ reset assertion. This prevents invalid reset assertion due to switch bounce.

Low-Power, Adjustable Battery Monitors with Hysteresis and Integrated μP Reset

Typical Operating Characteristics

($V_{DD} = 3.6V$, $V_{CC} = 3.3V$, unless otherwise specified. Typical values are at $T_A = +25^\circ C$.)

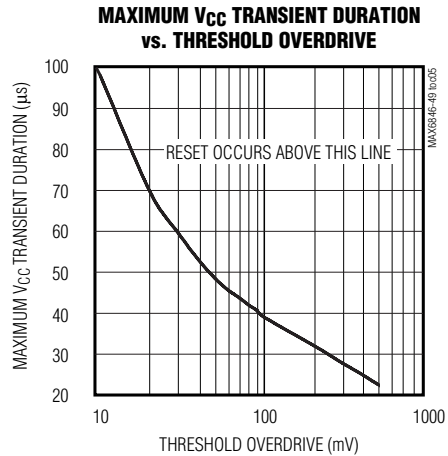
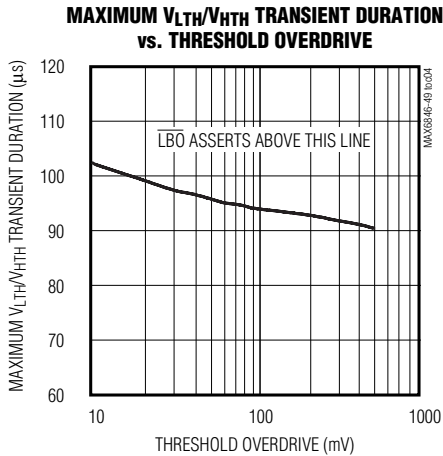
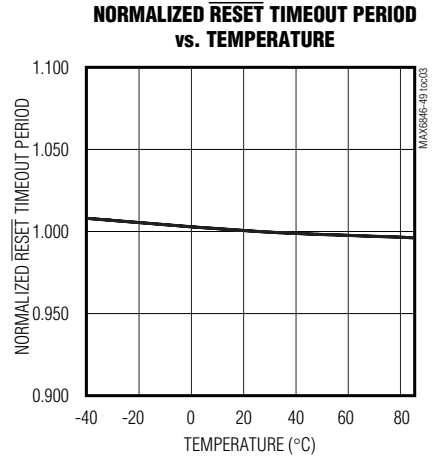
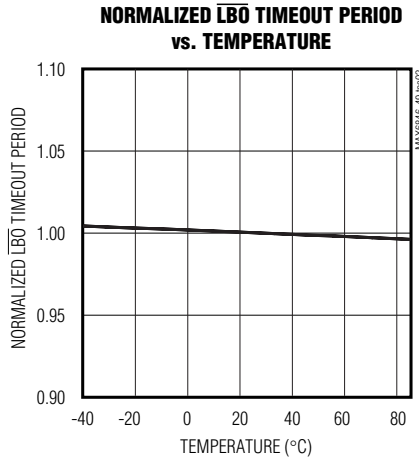
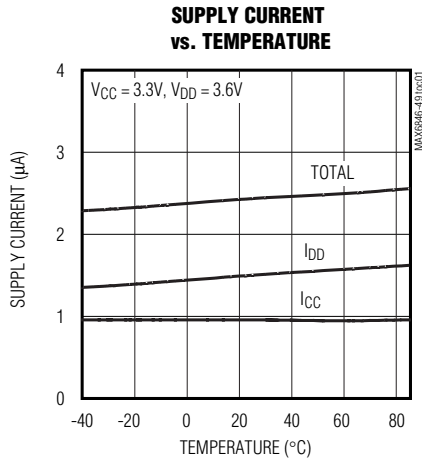

Low-Power, Adjustable Battery Monitors with Hysteresis and Integrated μ P Reset

Typical Operating Characteristics (continued)

($V_{DD} = 3.6V$, $V_{CC} = 3.3V$, unless otherwise specified. Typical values are at $T_A = +25^\circ C$.)

NORMALIZED UPPER AND LOWER \overline{LBO} TRIP VOLTAGES vs. TEMPERATURE

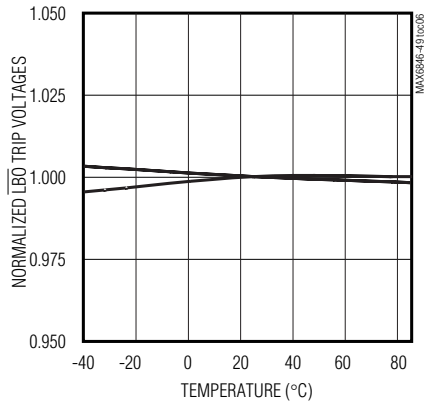

NORMALIZED \overline{RESET} THRESHOLD vs. TEMPERATURE

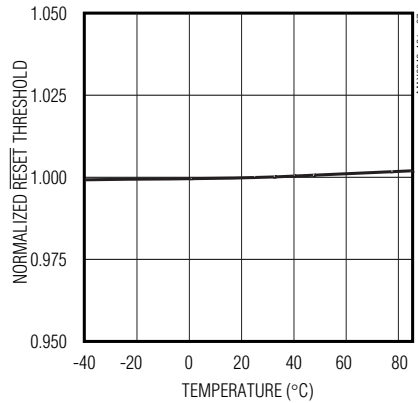

\overline{LBO} OUTPUT vs. SINK CURRENT

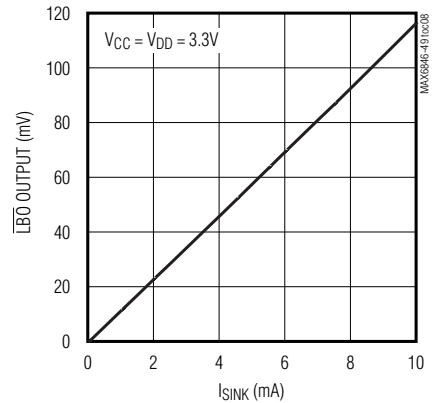

\overline{RESET} OUTPUT vs. SINK CURRENT

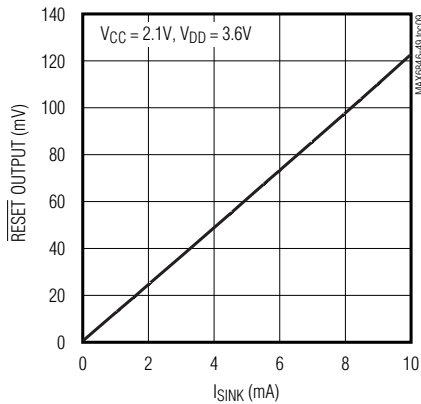

\overline{RESET} OUTPUT vs. SOURCE CURRENT

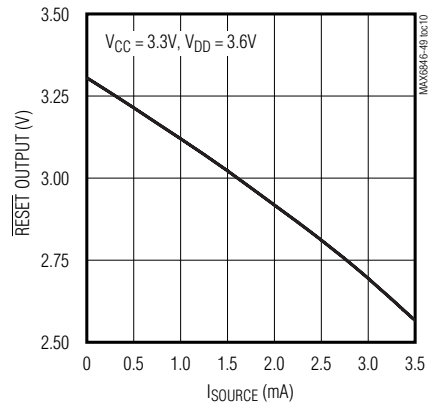

MAX6846-MAX6849

Low-Power, Adjustable Battery Monitors with Hysteresis and Integrated μ P Reset

Pin Description

PIN		NAME	FUNCTION
MAX6846/MAX6847	MAX6848/MAX6849		
1	1	V _{DD}	V _{DD} Supply. Device power supply if V _{DD} is greater than V _{CC} .
2	2	GND	Ground
3	3	LTHIN	LTH Threshold Monitor Input. A resistor-divider network sets the low threshold associated with $\overline{\text{LBOH}}$ and $\overline{\text{LBO}}$.
4	—	$\overline{\text{LBO}}$	Low-Battery Output, Active-Low, Open-Drain. $\overline{\text{LBO}}$ is asserted when LTHIN drops below the V _{LTH} specification and remains asserted until HTHIN rises above the V _{HTH} specification for at least 150ms.
5	5	$\overline{\text{RESET}}$	Reset Output, Active-Low, Push-Pull, or Open-Drain. $\overline{\text{RESET}}$ goes from high to low when the V _{CC} input drops below the selected reset threshold and remains low for the V _{CC} reset timeout period after V _{CC} exceeds the reset threshold. $\overline{\text{RESET}}$ is one-shot edge-trigger pulsed low for the $\overline{\text{MR}}$ reset timeout period when the $\overline{\text{MR}}$ input is pulled low. $\overline{\text{RESET}}$ is an open-drain output for the MAX6846/MAX6848, and a push-pull output for the MAX6847/MAX6849. The push-pull outputs are referenced to V _{CC} . $\overline{\text{RESET}}$ is guaranteed to be in the correct logic state for V _{DD} or V _{CC} \geq 10V.
6	—	$\overline{\text{MR}}$	Manual Reset Input, Active-Low, Internal 1.5k Ω Pullup to V _{CC} . Pull $\overline{\text{MR}}$ low to assert a one-shot reset output pulse for the $\overline{\text{MR}}$ reset timeout period. Leave unconnected or connect to V _{CC} if unused. The $\overline{\text{MR}}$ input is debounced for $\overline{\text{MR}}$ rising edges to prevent false reset events.
7	7	HTHIN	HTH Threshold Monitor Input. A resistor-divider network sets the high threshold associated with $\overline{\text{LBOH}}$ and $\overline{\text{LBO}}$.
8	8	V _{CC}	V _{CC} Voltage Input. Input for V _{CC} reset threshold monitor and device power supply if V _{CC} is greater than V _{DD} .
—	6	$\overline{\text{LBOH}}$	Low-Battery Output High, Active-Low, Open-Drain. $\overline{\text{LBOH}}$ is asserted when HTHIN drops below the V _{HTH} specification. $\overline{\text{LBOH}}$ is deasserted when HTHIN rises above the V _{HTH+} specification for at least 150ms.
—	4	$\overline{\text{LBOL}}$	Low-Battery Output Low, Active-Low, Open-Drain. $\overline{\text{LBOL}}$ is asserted when LTHIN drops below the V _{LTH} specification. $\overline{\text{LBOL}}$ is deasserted when LTHIN rises above the V _{LTH+} specification for at least 150ms.

Detailed Description

The MAX6846–MAX6849 family is available with several monitoring options. The MAX6846/MAX6847 have single low-battery outputs and the MAX6848/MAX6849 have dual low-battery outputs (see Figures 1a and 1b).

The MAX6846–MAX6849 combine a 615mV reference with two comparators, logic, and timing circuitry to provide the user with information about the charge state of the power-supply batteries. The MAX6848/MAX6849 monitor separate high-voltage and low-voltage thresholds to determine battery status. The output(s) can be used to signal when the battery is charged, when the battery is low, and when the battery is empty. User-

adjustable thresholds are ideal for monitoring single-cell Li+ or multicell alkaline/NiCd/NiMH power supplies.

When the power-supply voltage drops below the specified low threshold, the low-battery output asserts. When the voltage rises above the specified high threshold following a 150ms (min) timeout period, the low-battery output is deasserted. This ensures the supply voltage has stabilized before power-converter or microprocessor activity is enabled.

These devices also have an independent μ P supervisor that monitors V_{CC} and provides an active-low reset output. A manual reset function is available to allow the user to reset the μ P with a pushbutton.

Low-Power, Adjustable Battery Monitors with Hysteresis and Integrated μP Reset

MAX6846-MAX6849

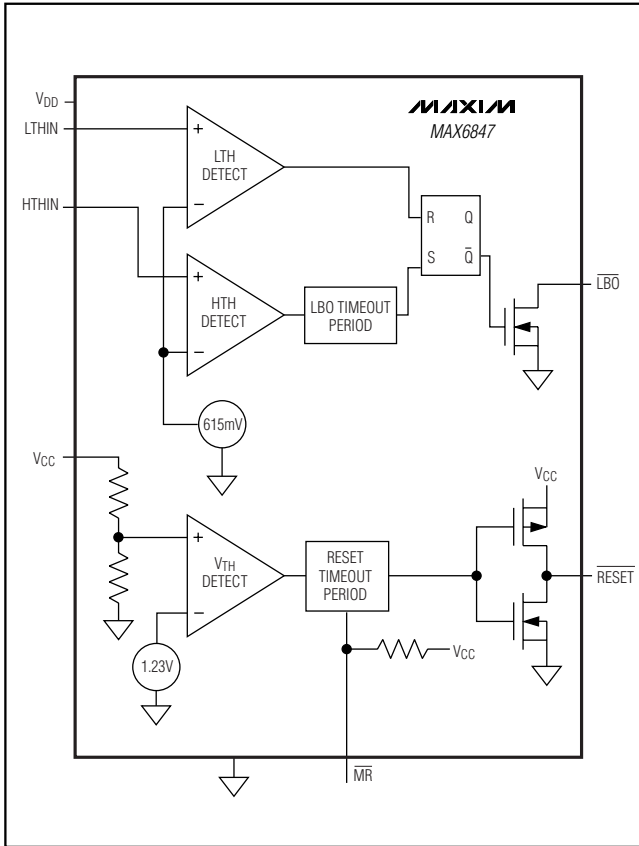

Figure 1a. MAX6847 Functional Diagram

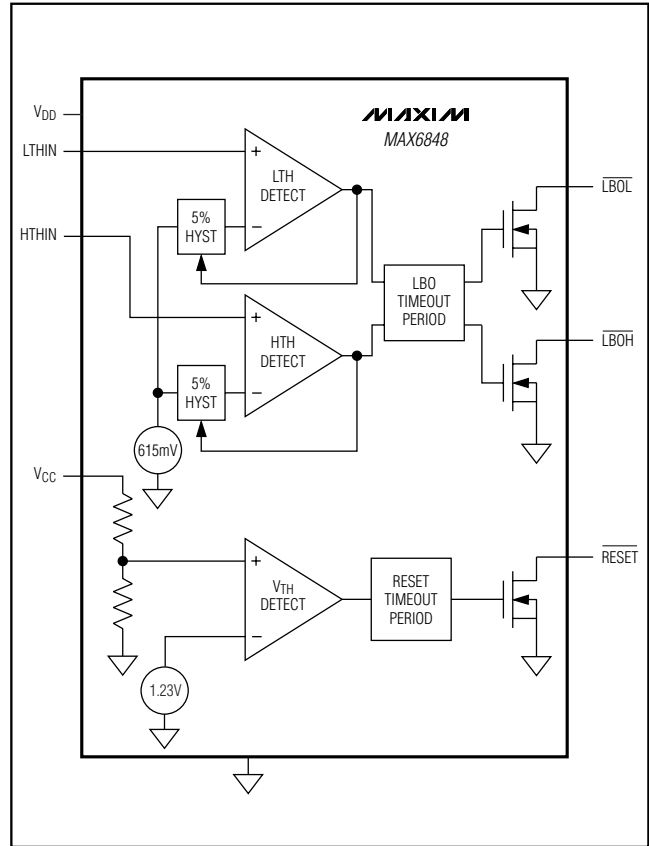

Figure 1b. MAX6848 Functional Diagram

Low-Battery Output

The low-battery outputs are available in active-low ($\overline{\text{LBO}}$, $\overline{\text{LBOH}}$, $\overline{\text{LBOH}}$), open-drain configurations. The low-battery outputs can be pulled to a voltage independent of V_{CC} or V_{DD} , up to 5.5V. This allows the device to monitor and operate from direct battery voltage while interfacing to higher voltage microprocessors.

The MAX6846/MAX6847 single-output voltage monitors provide a single low-battery output, $\overline{\text{LBO}}$. $\overline{\text{LBO}}$ asserts when V_{LTH} drops below V_{LTH-} and remains asserted for at least 150ms after V_{HTH} rises above V_{HTH} (see Figure 2). The MAX6848/MAX6849 dual-output voltage monitors provide two low-battery outputs: $\overline{\text{LBOH}}$ and $\overline{\text{LBOH}}$. $\overline{\text{LBOH}}$ asserts when V_{HTH} drops below V_{HTH-} and remains asserted for at least 150ms after V_{HTH}

rises above V_{HTH+} . $\overline{\text{LBOH}}$ asserts when V_{LTH} drops below V_{LTH-} and remains asserted for at least 150ms after V_{LTH} rises above V_{LTH+} (see Figure 3). For fast-rising V_{DD} input, the $\overline{\text{LBOH}}$ timeout period must complete before the $\overline{\text{LBOH}}$ timeout period begins.

Reset Output

The MAX6846-MAX6849 provide an active-low reset output ($\overline{\text{RESET}}$). $\overline{\text{RESET}}$ is asserted when the voltage at V_{CC} falls below the reset threshold level. Reset remains asserted for the reset timeout period after V_{CC} exceeds the threshold. If V_{CC} goes below the reset threshold before the reset timeout period is completed, the internal timer restarts (see Figure 4). The MAX6846/MAX6848 have open-drain reset outputs, while the MAX6847/MAX6849 have push-pull reset outputs.

Low-Power, Adjustable Battery Monitors with Hysteresis and Integrated μ P Reset

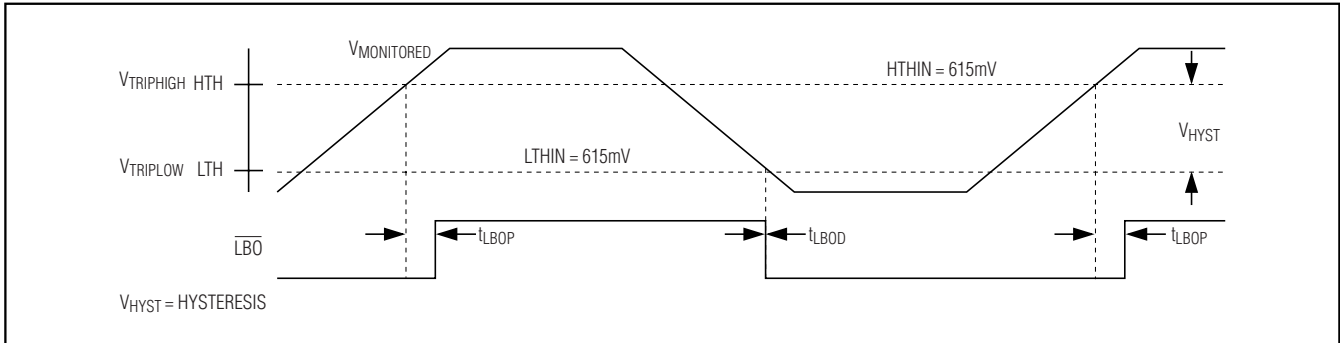

Figure 2. Single Low-Battery Output Timing

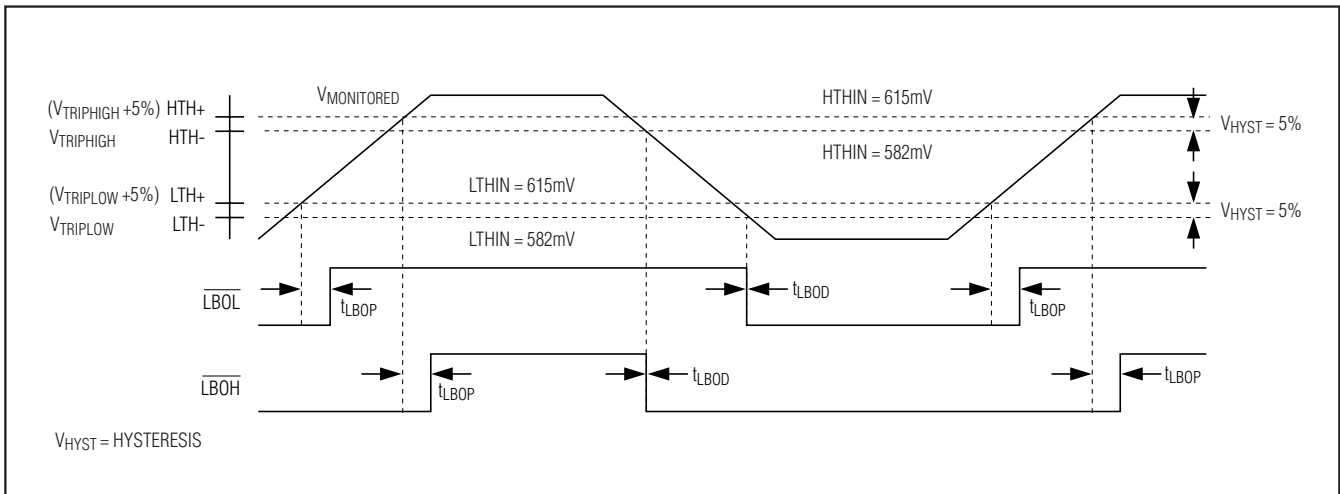

Figure 3. Dual Low-Battery Output Timing

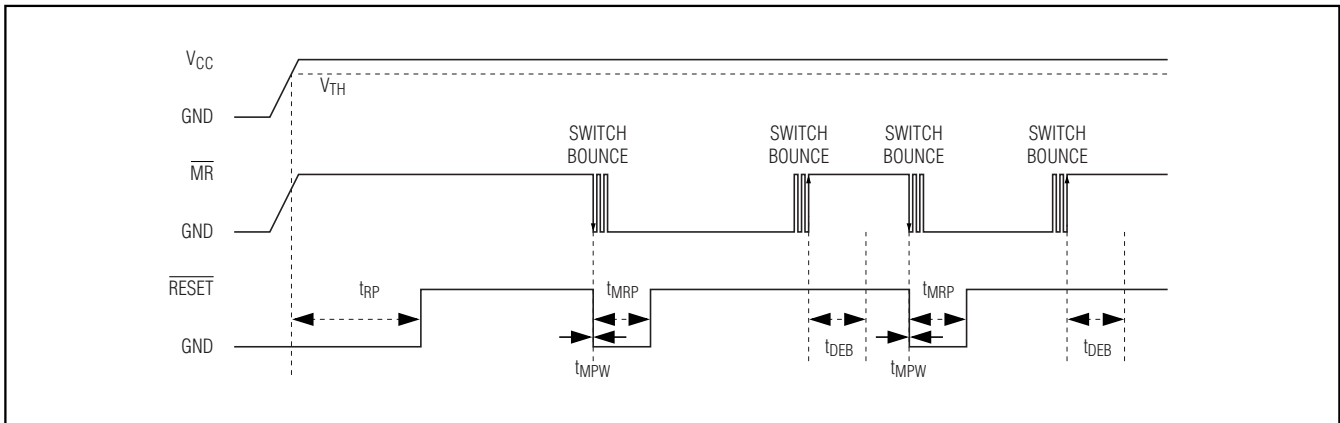

Figure 4. RESET Timing Diagram

Low-Power, Adjustable Battery Monitors with Hysteresis and Integrated μP Reset

MAX6846-MAX6849

Manual Reset

Many microprocessor-based products require manual reset capability, allowing the operator, a test technician, or external logic circuitry to initiate a reset while the monitored supplies remain above their reset thresholds. These devices have a dedicated active-low $\overline{\text{MR}}$ pin. When $\overline{\text{MR}}$ is pulled low, $\overline{\text{RESET}}$ asserts a one-shot low pulse for the $\overline{\text{MR}}$ reset timeout period. The $\overline{\text{MR}}$ input has an internal $1.5\text{k}\Omega$ pullup resistor to V_{CC} and can be left unconnected if not used. $\overline{\text{MR}}$ can be driven with CMOS-logic levels, open-drain/open-collector outputs, or a momentary pushbutton switch to GND (the $\overline{\text{MR}}$ function is internally debounced for the t_{DEB} timeout period) to create a manual reset function. If $\overline{\text{MR}}$ is driven from long cables, or if the device is used in a noisy environment, connect a $0.1\mu\text{F}$ capacitor from $\overline{\text{MR}}$ to GND to provide additional noise immunity (see Figure 4).

Hysteresis

Hysteresis increases the comparator's noise margin by increasing the upper threshold or decreasing the lower threshold. The hysteresis prevents the output from oscillating (chattering) when monitor input is near the low-battery threshold. This is especially important for applications where the load on the battery creates significant fluctuations in battery voltages (see Figures 2 and 3).

For the MAX6846/MAX6847, hysteresis is set using three external resistors (see Figure 5). The MAX6848/MAX6849 have dual, low-battery input levels. Each input level has a 5% (typ) hysteresis.

Applications Information

Resistor-Value Selection (Programming the Adjustable Thresholds)

MAX6846/MAX6847

$$V_{\text{LTH}} = V_{\text{HTH}} = 615\text{mV}$$

$$V_{\text{TRIPLOW}} = V_{\text{LTH}} \times \left(\frac{R1 + R2 + R3}{R2 + R3} \right)$$

$$V_{\text{TRIPHIGH}} = V_{\text{HTH}} \times \left(\frac{R1 + R2 + R3}{R3} \right)$$

$$R_{\text{TOTAL}} = R1 + R2 + R3$$

Use the following steps to determine values for R1, R2, and R3 of Figure 5.

- 1) Choose a value for R_{TOTAL} , the sum of R1, R2, and R3. Because the MAX6846/MAX6847 have very high input impedance, R_{TOTAL} can be up to $500\text{k}\Omega$.

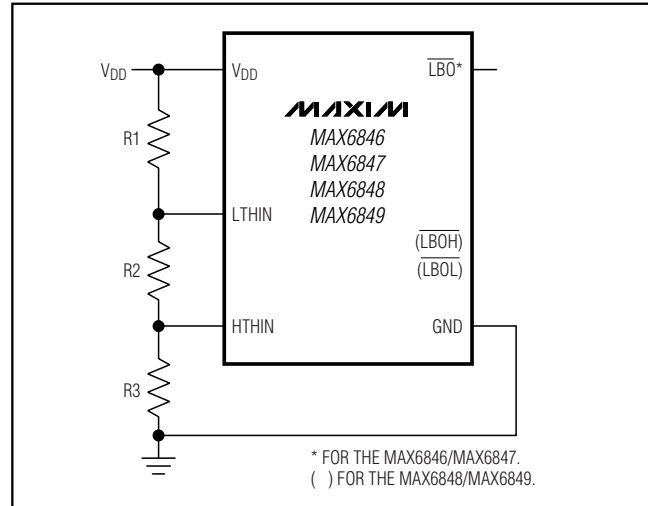

Figure 5. Adjustable Threshold Selection

- 2) Calculate R3 based on R_{TOTAL} and the desired upper trip point:

$$R3 = \frac{615\text{mV} \times R_{\text{TOTAL}}}{V_{\text{TRIPHIGH}}}$$

- 3) Calculate R2 based on R_{TOTAL} , R3, and the desired lower trip point:

$$R2 = \left(\frac{615\text{mV} \times R_{\text{TOTAL}}}{V_{\text{TRIPLOW}}} \right) - R3$$

- 4) Calculate R1 based on R_{TOTAL} , R3, and R2:

$$R1 = R_{\text{TOTAL}} - R2 - R3$$

MAX6848/MAX6849

$$V_{\text{LTH-}} = V_{\text{HTH-}} = 582\text{mV}$$

$\overline{\text{LBO}}$ low-trip level:

$$V_{\text{TRIPLOW}} = V_{\text{LTH-}} \times \left(\frac{R1 + R2 + R3}{R2 + R3} \right)$$

$\overline{\text{LBOH}}$ low-trip level:

$$V_{\text{TRIPHIGH}} = V_{\text{HTH-}} \times \left(\frac{R1 + R2 + R3}{R3} \right)$$

$$R_{\text{TOTAL}} = R1 + R2 + R3$$

Use the following steps to determine values for R1, R2, and R3 of Figure 5.

Low-Power, Adjustable Battery Monitors with Hysteresis and Integrated μP Reset

- 1) Choose a value for R_{TOTAL} , the sum of R_1 , R_2 , and R_3 . Because the MAX6848/MAX6849 have very high input impedance, R_{TOTAL} can be up to $500k\Omega$.
- 2) Calculate R_3 based on R_{TOTAL} and the desired upper trip point:

$$R_3 = \frac{582mV \times R_{TOTAL}}{V_{TRIPHIGH}}$$

- 3) Calculate R_2 based on R_{TOTAL} , R_3 , and the desired lower trip point:

$$R_2 = \left(\frac{582mV \times R_{TOTAL}}{V_{TRIPLOW}} \right) - R_3$$

- 4) Calculate R_1 based on R_{TOTAL} , R_3 , and R_2 :

$$R_1 = R_{TOTAL} - R_2 - R_3$$

- 5) \overline{LBOL} high-trip level:

$$V_{TRIPLOW} \times 1.05$$

- 6) \overline{LBOH} high-trip level:

$$V_{TRIPHIGH} \times 1.05$$

Monitoring Multicell Battery Applications

For monitoring multicell $Li+$ (or a higher number of alkaline/NiCd/NiMH cells), connect V_{DD} to a supply voltage between 1.6V to 5.5V. Figure 6 shows V_{DD} connected directly to V_{CC} . To calculate the values of R_1 , R_2 , and R_3 , see the *Resistor-Value Selection* section.

DC-DC Converter Application

The MAX6848/MAX6849 dual battery monitors can be used in conjunction with a DC-DC converter to power microprocessor systems using a single $Li+$ cell or two

to three alkaline/NiCd/NiMH cells. The \overline{LBOH} output indicates that the battery voltage is weak, and is used to warn the microprocessor of potential problems. Armed with this information, the microprocessor can reduce system power consumption. The \overline{LBOL} output indicates the battery is empty and system power should be disabled. By connecting \overline{LBOL} to the \overline{SHDN} pin of the DC-DC converter, power to the microprocessor is removed. Microprocessor power does not return until the battery has recharged to a voltage greater than V_{LTH+} (see Figure 7).

Table 1. Factory-Trimmed V_{CC} Reset Threshold Levels

PART NO. SUFFIX (_)	V_{CC} NOMINAL RESET THRESHOLD (V)
T	3.075
S	2.925
R	2.625
Z	2.313
Y	2.188
W	1.665
V	1.575

Table 2. V_{CC} Reset Timeout Period Suffix Guide

TIMEOUT PERIOD SUFFIX	ACTIVE TIMEOUT PERIOD (ms)	
	MIN	MAX
D3	150	300
D7	1200	2400

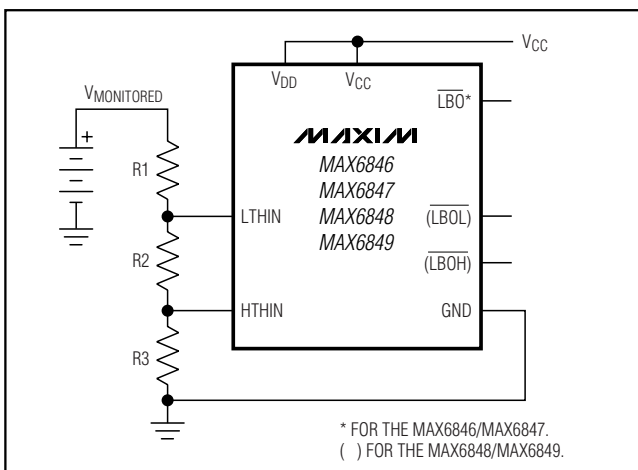

Figure 6. Monitoring Multicell $Li+$ Applications

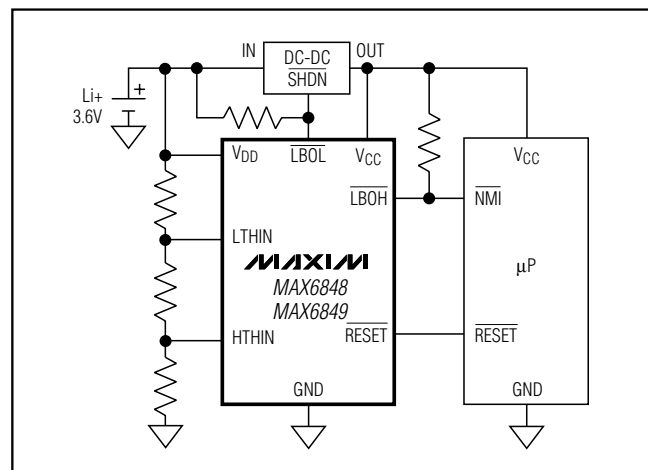

Figure 7. DC-DC Converter Application

Low-Power, Adjustable Battery Monitors with Hysteresis and Integrated μ P Reset

Selector Guide

PART	OPEN-DRAIN RESET	PUSH-PULL RESET	SINGLE LOW-BATTERY OUTPUT	DUAL LOW-BATTERY OUTPUT
MAX6846	X	—	X	—
MAX6847	—	X	X	—
MAX6848	X	—	—	X
MAX6849	—	X	—	X

Standard Versions Table

PART	TOP MARK
MAX6846KARD3	AEJI
MAX6846KASD3	AEJD
MAX6846KAWD3	AEJK
MAX6846KAZD3	AEJJ
MAX6847KARD3	AEJE
MAX6847KASD3	AEJL
MAX6847KAWD3	AEJN
MAX6847KAZD3	AEJM
MAX6848KARD3	AEJP
MAX6848KASD3	AEJO
MAX6848KAWD3	AEJR
MAX6848KAZD3	AEJQ
MAX6849KARD3	AEJT
MAX6849KASD3	AEJS
MAX6849KAWD3	AEJV
MAX6849KAZD3	AEJU

Typical Application Circuit

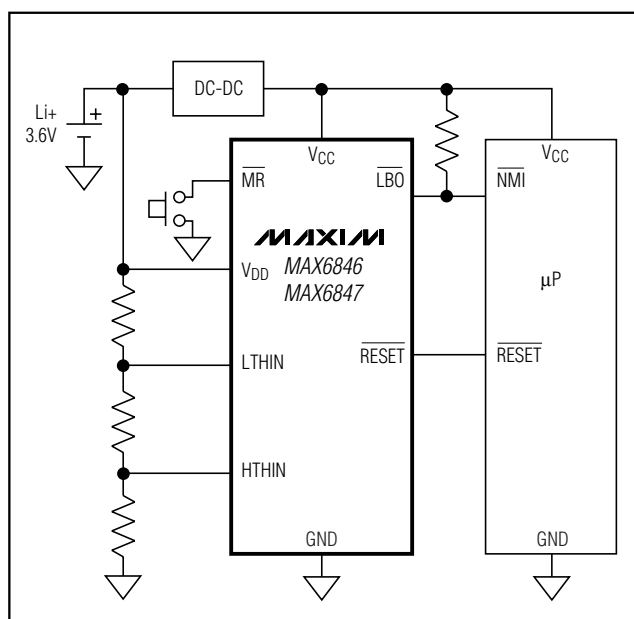

Chip Information

TRANSISTOR COUNT: 1478

PROCESS: BiCMOS

MAX6846-MAX6849

Low-Power, Adjustable Battery Monitors with Hysteresis and Integrated μ P Reset

Package Information

(The package drawing(s) in this data sheet may not reflect the most current specifications. For the latest package outline information go to www.maxim-ic.com/packages.)

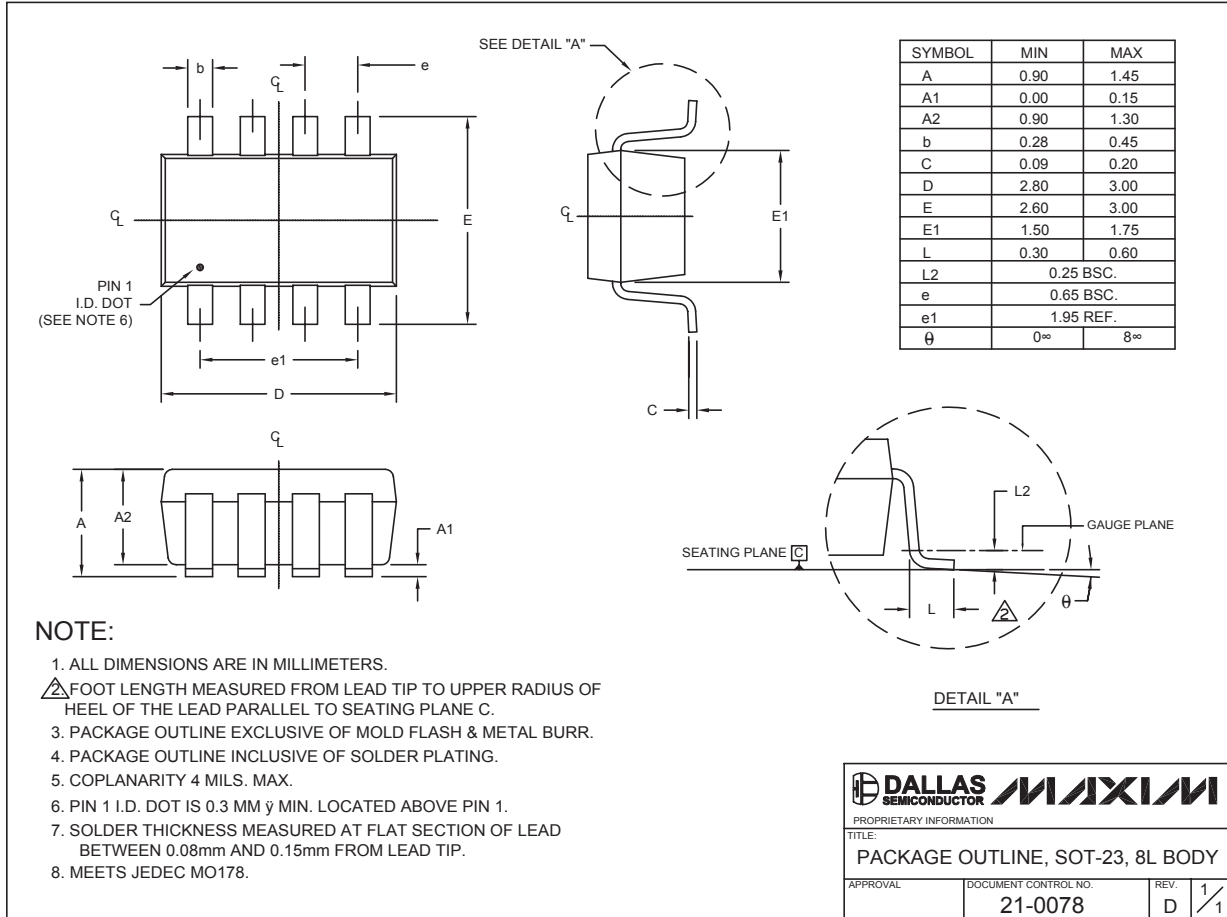

SOT23, 8L, EPS

Maxim cannot assume responsibility for use of any circuitry other than circuitry entirely embodied in a Maxim product. No circuit patent licenses are implied. Maxim reserves the right to change the circuitry and specifications without notice at any time.

12 _____ Maxim Integrated Products, 120 San Gabriel Drive, Sunnyvale, CA 94086 408-737-7600