

PLEASE CHECK WWW.MOLEX.COM FOR LATEST PART INFORMATION

Part Number: **0334680001**
Status: **Active**
Overview: mx64 sealed single row connectors
Description: 2.54mm (.100") Pitch MX64™ Terminal, Tin (Sn) Plating, 22 AWG, Right Reel Payoff, Also used with MX123™ Female Receptacle Housing

Documents:

[Drawing \(PDF\)](#) [RoHS Certificate of Compliance \(PDF\)](#)

General

Product Family	Crimp Terminals
Series	33468
Comments	Right Reel Payoff
Crimp Quality Equipment	Yes
Overview	mx64 sealed single row connectors
Product Name	MX123, MX64™

Physical

Gender	Female
Material - Metal	Copper
Material - Plating Mating	Tin
Material - Plating Termination	Tin
Packaging Type	Reel
Plating min: Mating (µin)	100
Plating min: Mating (µm)	2.5
Plating min: Termination (µin)	76
Plating min: Termination (µm)	1.90
Termination Interface: Style	Crimp or Compression
Wire Insulation Diameter	1.50-2.06mm (.059-.081")
Wire Size AWG	22
Wire Size mm²	N/A

Material Info

Reference - Drawing Numbers

Packaging Specification	PK-30907-759, PK-31300-516
Sales Drawing	SD-33468-001

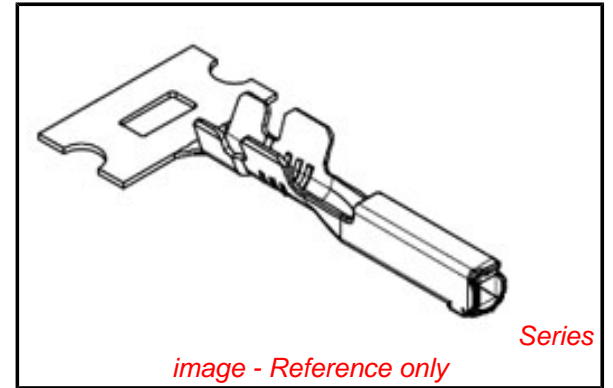

EU RoHS

ELV and RoHS Compliant
REACH SVHC
Contains SVHC: No
Halogen-Free Status

China RoHS



Need more information on product environmental compliance?

Email productcompliance@molex.com
 For a multiple part number RoHS Certificate of Compliance, [click here](#)

Please visit the [Contact Us](#) section for any non-product compliance questions.

Search Parts in this Series

[33468Series](#)

Use With

MX64™ Sealed Single Row Crimp Housing 31403 , MX123™ Female Receptacle Housing 34566 , 34576

Application Tooling | FAQ

Tooling specifications and manuals are found by selecting the products below. Crimp Height Specifications are then contained in the Application Tooling Specification document.

Global

Description	Product #
Hand Crimp Tool	0638114200
Manual Extraction Tool	0638131400

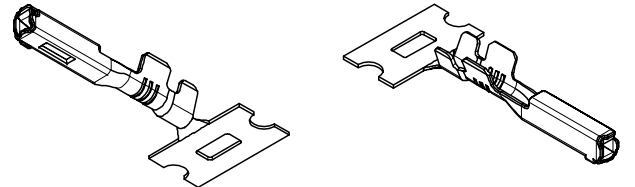
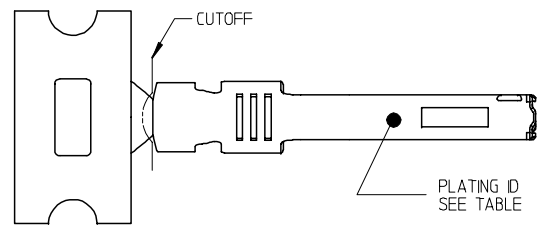
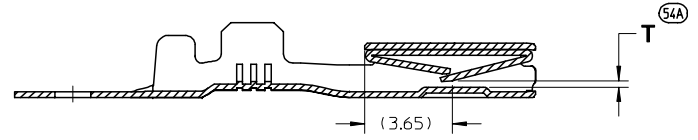
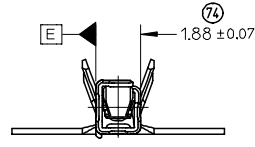
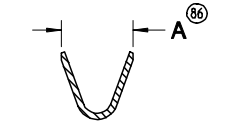
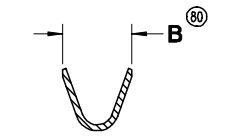
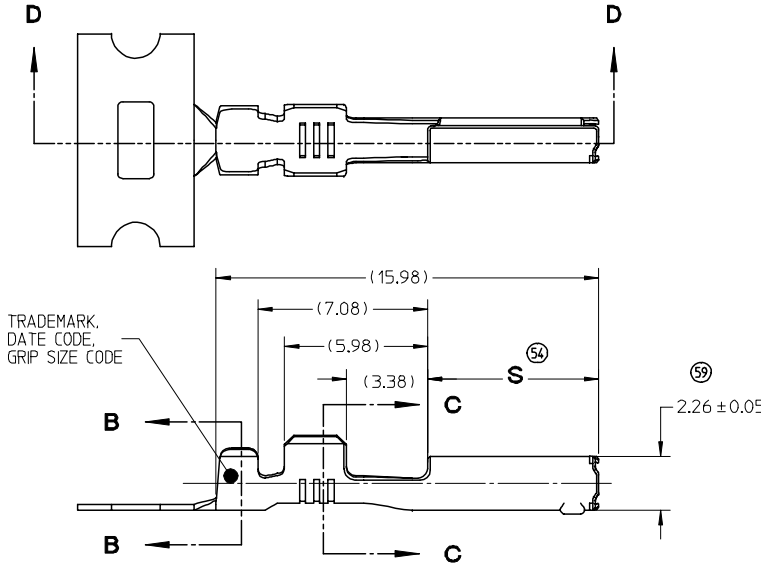

ISO VIEWS
SCALE 3:1

- NOTES: (UNLESS OTHERWISE SPECIFIED)
1. MATERIALS: SEE TABLE
 2. PACKAGING SPECIFICATION: PK-31300-516 AND PK-30907-759
 3. CRIMPED LEAD MEETS THE FOLLOWING:
 - 3.1. SAE/USCAR-21, MAY 2002
 - 3.2. SAE/USCAR-2, REV. 3, APRIL 2001
 - 3.3. SAE/USCAR-12, REV. 2
 - 3.4. GMW #3191 AUGUST 22, 2000 (DRAFT) TEMPERATURE CLASS 3, APPLES ONLY TO Au PARTS

GRIP SIZE GAGE	GRIP SIZE CODE	PART NUMBER	PART REV	REEL PAYOFF DIRECTION	DIM A	DIM B	DIM S	DIM T	BASE MATERIAL	PLATING ID	LUBRICATION
22	A	33468-0002	G	D	2.3	2.3	7.15 ± 0.10	0.26 ± 0.07	COPPER ALLOY	Sn Lead Free	NO
		33468-0001	G	B					COPPER ALLOY	Au Lead Free	NO
		33467-0003	G	B	2.3	2.3	6.97-7.27	0.26 ± 0.07	COPPER ALLOY	Au Lead Free	NO
18/20	B	33468-0004	G	D	3.0	2.9	7.15 ± 0.10	0.26 ± 0.07	COPPER ALLOY	Sn Lead Free	NO
		33468-0003	G	B					COPPER ALLOY	Au Lead Free	NO
		33467-0006	G	D	3.0	2.9	6.97-7.27	0.26 ± 0.07	COPPER ALLOY	Au Lead Free	NO
		33467-0005	G	B					COPPER ALLOY	Au Lead Free	NO

ENTER DESCRIPTION EC NO: UAU2007-0559 (DR)W.DHEMNI 2007/04/12 (CHK)D.D.HEMNI 2007/04/13 (APP)R.BOSER 2007/04/13	QUALITY SYMBOLS ▽=0 ▽=0	GENERAL TOLERANCES (UNLESS SPECIFIED) <table border="1"> <tr> <th></th> <th>MM</th> <th>INCH</th> </tr> <tr> <td>4 PLACES</td> <td>± ---</td> <td>± ---</td> </tr> <tr> <td>3 PLACES</td> <td>± ---</td> <td>± ---</td> </tr> <tr> <td>2 PLACES</td> <td>± 0.10</td> <td>± ---</td> </tr> <tr> <td>1 PLACE</td> <td>± 0.3</td> <td>± ---</td> </tr> </table>		MM	INCH	4 PLACES	± ---	± ---	3 PLACES	± ---	± ---	2 PLACES	± 0.10	± ---	1 PLACE	± 0.3	± ---	DIMENSION STYLE MM ONLY SCALE 5:1 DESIGN UNITS METRIC THIRD ANGLE PROJECTION
		MM	INCH															
	4 PLACES	± ---	± ---															
	3 PLACES	± ---	± ---															
2 PLACES	± 0.10	± ---																
1 PLACE	± 0.3	± ---																
DRAWN BY L. PULLIAM DATE 2/3/2006	CHECKED BY D. HEMNANI DATE 2/3/2006	APPROVED BY B. MOSER DATE 2/3/2006	TITLE MX64 RECEPTACLE TERMINAL															
MATERIAL NO. SEE TABLE	DOCUMENT NO. SD-33468-001	SHEET NO. 1 OF 3	MOLEX INCORPORATED															
SIZE B	THIS DRAWING CONTAINS INFORMATION THAT IS PROPRIETARY TO MOLEX INCORPORATED AND SHOULD NOT BE USED WITHOUT WRITTEN PERMISSION																	

WIRE APPLICATION SEE NOTE 2		APPLICATOR TOOLING INFORMATION TABLE																
SAE AWG	METRIC mm ²	A	B	C	D	E	F	G	H	J	K	L	M	N	P	R	S	T
		FOR TOLERANCE SEE APPLICATOR TOOLING TOLERANCE TABLE																
18	(0.8)	0.470	1.803	7.1	12.13	0.944	6.5	1.783	1.83	1.885	0.98	0.98	0.22	2.10	1.90	0.34	2.10	0.98
20	(0.5)	0.470	1.803	7.1	12.13	0.944	6.5	1.783	1.83	1.885	0.98	0.98	0.22	2.10	1.90	0.34	2.10	0.98
22	(0.35)	0.353	1.457	7.4	12.14	0.880	6.3	1.435	2.29	1.700	1.02	0.89	0.17	1.97	1.71	0.31	1.27	0.68

TERMINAL CRIMP INFORMATION TABLE				
PART NUMBER	CONDUCTOR CRIMP HEIGHT	CONDUCTOR CRIMP WIDTH	INSULATOR CRIMP HEIGHT	INSULATOR CRIMP WIDTH
	CCH TOL. ±0.05mm	CCW TOL. ±0.05mm	ICH TOL. ±0.1mm	ICW TOL. ±0.1mm
33467-0005 33467-0006 33468-0003 33468-0004	1.15	1.80	2.10	1.95
33467-0005 33467-0006 33468-0003 33468-0004	1.10	1.80	1.95	1.95
33467-0003 33467-0004 33468-0001 33468-0002	0.95	1.45	1.60	1.80

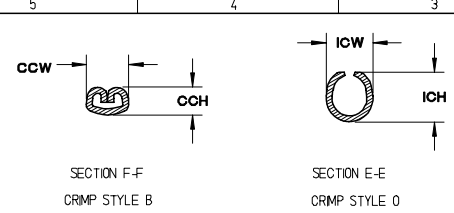

SUPPLIER APPLICATOR TOOLING TABLE SEE NOTE 4.2	
PART NUMBER	DESCRIPTION
63867-3000	MX64 CRIMP APPLICATOR WITH APPLICATOR TOOL KIT 18/20 AWG (PAYOFF DIRECTION D (LEFT PAYOFF)) (CONTACT MOLEX FOR PAYOFF DETAIL)
63867-3070	MX64 APPLICATOR TOOL KIT 18/20 AWG
63867-3100	MX64 CRIMP APPLICATOR WITH APPLICATOR TOOL KIT 22 AWG (PAYOFF DIRECTION D (LEFT PAYOFF)) (CONTACT MOLEX FOR PAYOFF DETAIL)
63867-3170	MX64 APPLICATOR TOOL KIT 22 AWG

- NOTES: (UNLESS OTHERWISE SPECIFIED, APPLIES TO CRIMPED LEAD ONLY)
- TERMINAL:
 - MATING (BLADE/PIN) SHALL CONFORM TO EWCAP-001 REV. B
 - RECEPTACLE CRIMPED LEAD MUST BE USED WITH MATCHING PLATING TYPE ON MALE TERMINAL
 - WIRE SHALL MEET THE FOLLOWING SPECIFICATIONS:
 - SAE: ESB-MIL123-A
WSS-MIL123-A1
SAE J1128 WITH OUTSIDE DIAMETER OF 1.47mm MINIMUM - 2.06mm MAXIMUM
 - METRIC: WSK-MIL126-A1
 - WIRE CONDITION AFTER CRIMP:
 - CRIMPED TERMINAL LEAD MUST BE ABLE TO PASS FREELY THROUGH THE CHECKING AD SHOWN ON SHEET 3
 - WIRE SURFACE MUST BE FREE OF SCRATCHES, GROVES OR DENTS
 - TOOLING:
 - FOR HAND CRIMPED TOOLING REFER 63811-4200
 - FOR APPLICATOR TOOLING REFER TO APPLICATOR TOOLING INFORMATION OR SUPPLIER APPLICATOR TOOLING TABLE

APPLICATOR TOOLING INFORMATION

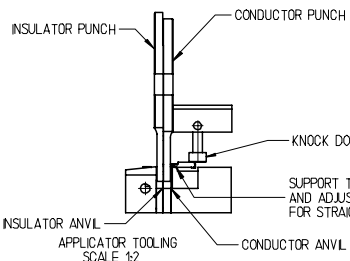

APPLICATOR TOOLING TOLERANCE TABLE	
3 PLACE	±0.005
2 PLACE	±0.025
1 PLACE	±0.13
ANGULAR	±0.5°

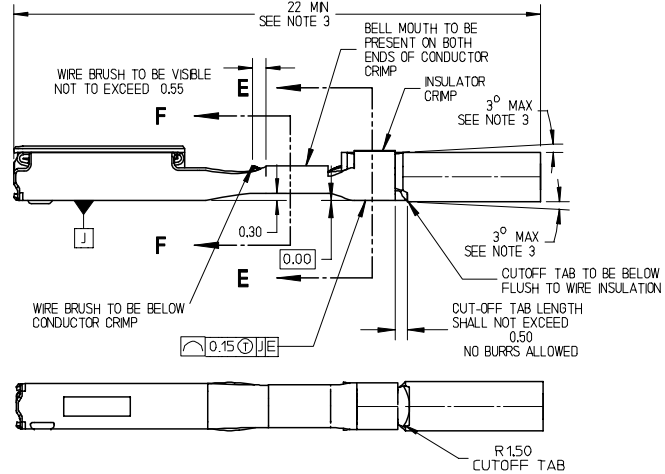
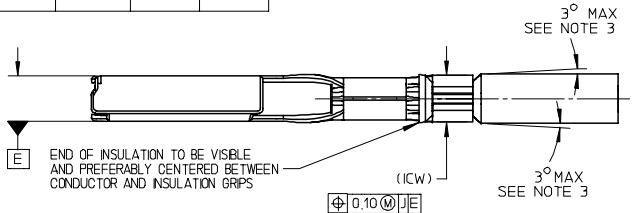

(4.2) WIRE STRIP LENGTH

THIS SHEET APPLIES TO RECEPTACLE CRIMPED LEAD ONLY

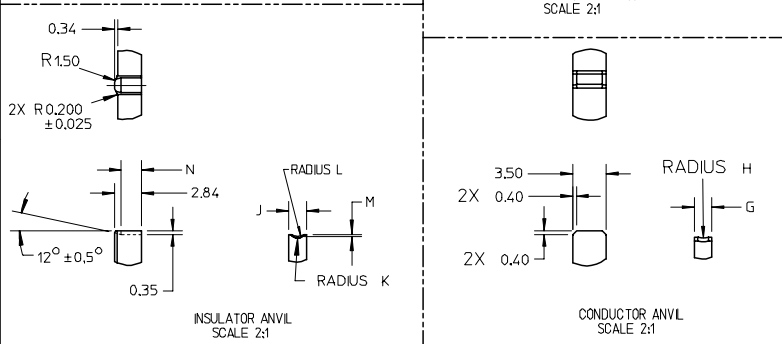
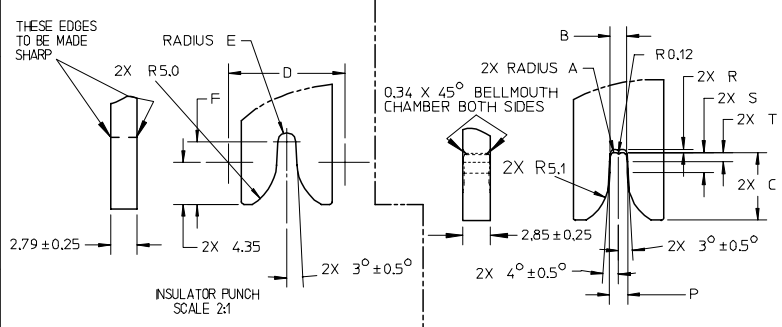

ENTER DESCRIPTION EC NO: UAU2007-0559 IDRWINDHEWANI 2007/04/12 CHKDDJ.HEMNANI 2007/04/13 APPR:BMOSER 2007/04/13	QUALITY SYMBOLS =0 =0	GENERAL TOLERANCES (UNLESS SPECIFIED)		DIMENSION STYLE MM ONLY		SCALE 5:1	DESIGN UNITS METRIC	THIRD ANGLE PROJECTION		
		mm	INCH	DRAWN BY L. PULLIAM	DATE 2/3/2006	TITLE MX64 RECEPTACLE TERMINAL	MOLEX INCORPORATED			
G	DESCRIPTION	4 PLACES	± ---	± ---	CHECKED BY D. HEMNANI	DATE 2/3/2006	SD-33468-001			
		3 PLACES	± ---	± ---	APPROVED BY B. MOSER	DATE 2/3/2006				
		2 PLACES	± 0.10	± ---	MATERIAL NO. SEE TABLE		DOCUMENT NO. SD-33468-001			
		1 PLACE	± 0.3	± ---	SIZE B		SHEET NO. 2 OF 3			
		ANGULAR ± 3°		THIS DRAWING CONTAINS INFORMATION THAT IS PROPRIETARY TO MOLEX INCORPORATED AND SHOULD NOT BE USED WITHOUT WRITTEN PERMISSION						

SUPPLIER CHECKING AID TOOLING	
PART NUMBER	DESCRIPTION
63867-3008	MX64 CRIMPED LEAD STRAIGHTNESS CHECKING AID FOR 18 AWG, 20 AWG AND 22 AWG

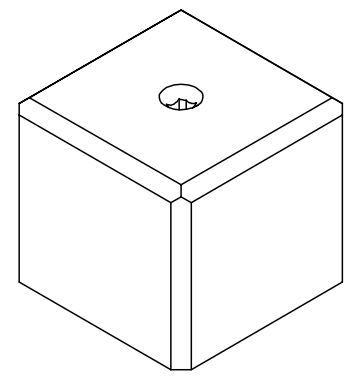
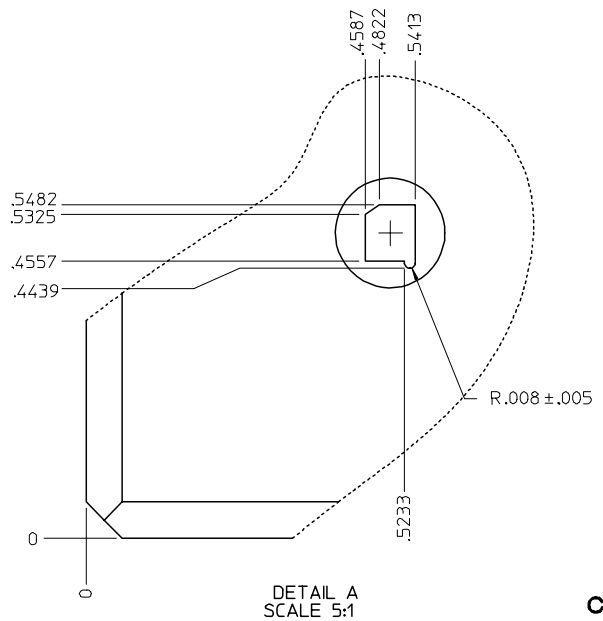
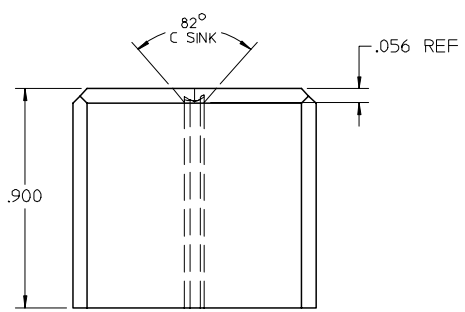
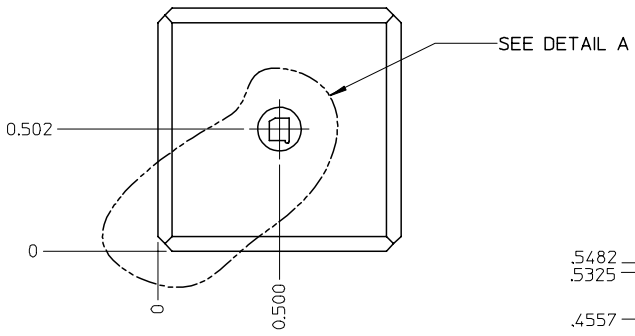

- NOTES: (UNLESS OTHERWISE SPECIFIED)
1. MATERIAL: STEEL 4140 PREHARDENED
 2. FINISH:
 - 2.1 SURFACE: BLACK OXIDE
 - 2.2 INSIDE PROFILE: POLISH
 3. ALL DIMENSIONS ON THIS SHEET ARE IN INCHES
 4. TOLERANCES ON THIS SHEET ARE IN INCHES
 - 2 PLACES ± .01
 - 3 PLACES ± .005
 - 4 PLACES ± .0002

CRIMPED LEAD STRAIGHTNESS CHECKING AID FOR 18 AWG, 20 AWG AND 22 AWG

THIS SHEET APPLIES TO RECEPTACLE CRIMPED LEAD ONLY

ENTER DESCRIPTION EC NO: UAU2007-0559 DRAWN:HEMNI 2007/04/12 CHKDD:HEMNI 2007/04/13 APPR:BMOSER 2007/04/13	QUALITY SYMBOLS ▽=0 ▽=0	GENERAL TOLERANCES (UNLESS SPECIFIED)		DIMENSION STYLE MM ONLY	SCALE 2:1	DESIGN UNITS METRIC	THIRD ANGLE PROJECTION	
				DRAWN BY L. PULLIAM	DATE 2/3/2006	TITLE MX64 RECEPTACLE TERMINAL		
				CHECKED BY D. HEMNANI	DATE 2/3/2006	APPROVED BY B. MOSER		
				MATERIAL NO. SEE TABLE		DATE 2/3/2006	DOCUMENT NO. SD-33468-001	
REV	DESCRIPTION	ANGULAR ± 3 °		THIS DRAWING CONTAINS INFORMATION THAT IS PROPRIETARY TO MOLEX INCORPORATED AND SHOULD NOT BE USED WITHOUT WRITTEN PERMISSION				