

## 54, 74 Series GHz Logic

FEATURES:	DESCRIPTION:
<ul style="list-style-type: none"> <li>. Patented technology</li> <li>. Specified From <math>-40^{\circ}\text{C}</math> to <math>85^{\circ}\text{C}</math>, <math>-40^{\circ}\text{C}</math> to <math>125^{\circ}\text{C}</math>, and <math>-55^{\circ}\text{C}</math> to <math>125^{\circ}\text{C}</math></li> <li>. Operating frequency is faster than 600MHz</li> <li>. VCC Operates from 1.65V to 3.6V</li> <li>. Propagation delay &lt; 2ns max with 15pf load</li> <li>. Low input capacitance: 4pf typical</li> <li>. Latch-Up Performance Exceeds 250 mA Per JESD 17</li> <li>. ESD Protection Exceeds JESD 22</li> <li>. 5000-VHuman-BodyModel (A114-A)</li> <li>. 200-VMachineModel (A115-A)</li> <li>. Available in 14pin 150mil wide SOIC package</li> <li>. Available in 14pin Ceramic Dual Flatpack</li> <li>. Available in 20pin Leadless Ceramic Chip Carrier</li> </ul>	<p>Potato Semiconductor's PO74G74A is designed for world top performance using submicron CMOS technology to achieve higher than 600MHz TTL /CMOS output frequency with less than 2ns propagation delay.</p> <p>This dual D flip-flop is designed for 1.65-V to 3.6-V VCC operation.</p> <p>Inputs can be driven from either 3.3V or 5V devices. This feature allows the use of these devices as translators in a mixed 3.3V/5V system environment.</p>

### Pin Configuration

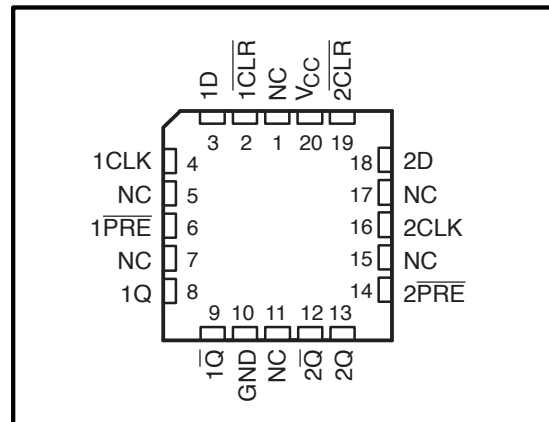
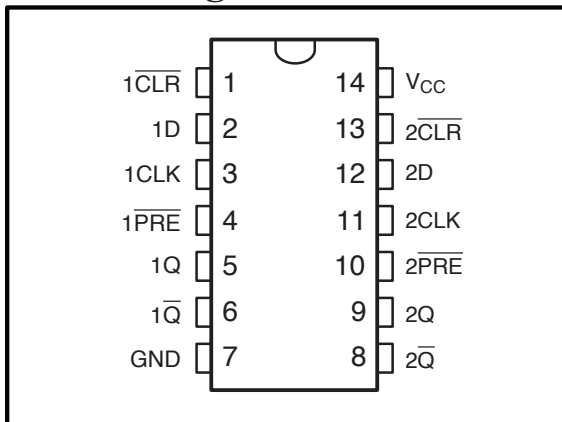

### Pin Description

INPUTS				OUTPUTS	
PRE	CLR	CLK	D	Q	Q̄
L	H	X	X	H	L
H	L	X	X	L	H
L	L	X	X	H	H
H	H	↑	H	H	L
H	H	↑	L	L	H
H	H	L	X	Q <sub>0</sub>	Q̄ <sub>0</sub>

### Logic Block Diagram

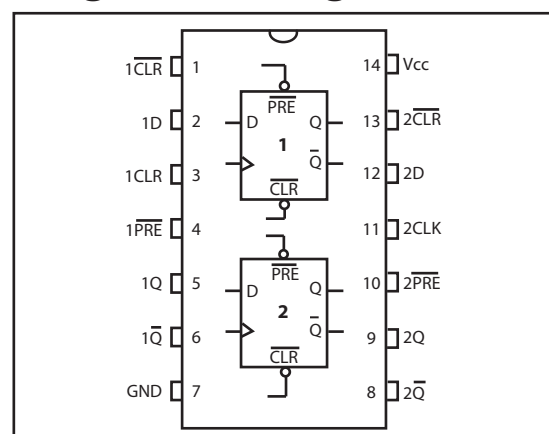

## 54, 74 Series GHz Logic

### Maximum Ratings

Description	Max	Unit
Storage Temperature	-65 to 150	°C
Operation Temperature	-55 to 125	°C
Operation Voltage	-0.5 to +4.6	V
Input Voltage	-0.5 to +5.5	V
Output Voltage	-0.5 to V <sub>cc</sub> +0.5	V

**Note:**

stresses greater than listed under Maximum Ratings may cause permanent damage to the device. This is a stress rating only and functional operation of the device at these or any other conditions above those indicated in the operational sections of this specification is not implied. Exposure to absolute maximum rating conditions for extended periods may affect reliability specification is not implied.

### DC Electrical Characteristics

Symbol	Description	Test Conditions	Min	Typ	Max	Unit
<b>V<sub>OH</sub></b>	Output High voltage	V <sub>cc</sub> =3V Vin=V <sub>IH</sub> or V <sub>IL</sub> , I <sub>OH</sub> = -12mA	<b>2.4</b>	<b>3</b>	-	<b>V</b>
<b>V<sub>OL</sub></b>	Output Low voltage	V <sub>cc</sub> =3V Vin=V <sub>IH</sub> or V <sub>IL</sub> , I <sub>OH</sub> =12mA	-	<b>0.3</b>	<b>0.5</b>	<b>V</b>
<b>V<sub>IH</sub></b>	Input High voltage	Guaranteed Logic HIGH Level (Input Pin)	<b>2</b>	-	<b>5.5</b>	<b>V</b>
<b>V<sub>IL</sub></b>	Input Low voltage	Guaranteed Logic LOW Level (Input Pin)	<b>-0.5</b>	-	<b>0.8</b>	<b>V</b>
<b>I<sub>IH</sub></b>	Input High current	V <sub>cc</sub> = 3.6V and Vin = 5.5V	-	-	<b>1</b>	<b>uA</b>
<b>I<sub>IL</sub></b>	Input Low current	V <sub>cc</sub> = 3.6V and Vin = 0V	-	-	<b>-1</b>	<b>uA</b>
<b>V<sub>IK</sub></b>	Clamp diode voltage	V <sub>cc</sub> = Min. And I <sub>IN</sub> = -18mA	-	<b>-0.7</b>	<b>-1.2</b>	<b>V</b>

**Notes:**

1. For conditions shown as Max. or Min., use appropriate value specified under Electrical Characteristics for the applicable device type.
2. Typical values are at V<sub>cc</sub> = 3.3V, 25 °C ambient.
3. This parameter is guaranteed but not tested.
4. Not more than one output should be shorted at one time. Duration of the test should not exceed one second.
5. V<sub>OH</sub> = V<sub>cc</sub> - 0.6V at rated current

## 54, 74 Series GHz Logic

### Power Supply Characteristics

Symbol	Description	Test Conditions (1)	Min	Typ	Max	Unit
<b>IccQ</b>	Quiescent Power Supply Current	Vcc=Max, Vin=Vcc or GND	-	<b>0.1</b>	<b>40</b>	<b>uA</b>

**Notes:**

1. For conditions shown as Max. or Min., use appropriate value specified under Electrical Characteristics for the applicable device type.
2. Typical values are at Vcc = 3.3V, 25°C ambient.
3. This parameter is guaranteed but not tested.
4. Not more than one output should be shorted at one time. Duration of the test should not exceed one second.

### Capacitance

Parameters (1)	Description	Test Conditions	Typ	Unit
<b>Cin</b>	Input Capacitance	Vin = 0V	<b>4</b>	<b>pF</b>
<b>Cout</b>	Output Capacitance	Vout = 0V	<b>6</b>	<b>pF</b>

**Notes:**

- 1 This parameter is determined by device characterization but not production tested.

### Switching Characteristics

Symbol	Description	Test Conditions (1)	Max	Min	Unit
<b>tsu</b>	Setup time before CLK ↑		-	<b>0.5</b>	<b>ns</b>
<b>th</b>	Hold time, data after CLK ↑		-	<b>0.5</b>	<b>ns</b>
<b>tPLH</b>	Propagation Delay CLK to Q	CL = 15pF	<b>2</b>	-	<b>ns</b>
<b>tPHL</b>	Propagation Delay CLK to Q	CL = 15pF	<b>2</b>	-	<b>ns</b>
<b>tr/tf</b>	Rise/Fall Time	0.8V – 2.0V	<b>0.8</b>	-	<b>ns</b>
<b>fmax</b>	Input Frequency	CL=2pF - 15pF	-	<b>600</b>	<b>MHz</b>

**Notes:**

1. See test circuits and waveforms.
2. tPLH, tPHL, tsu, and th are production tested. All other parameters guaranteed but not production tested.
3. Airflow of 1m/s is recommended for frequencies above 500MHz

**54, 74 Series GHz Logic**

**Test Waveforms**

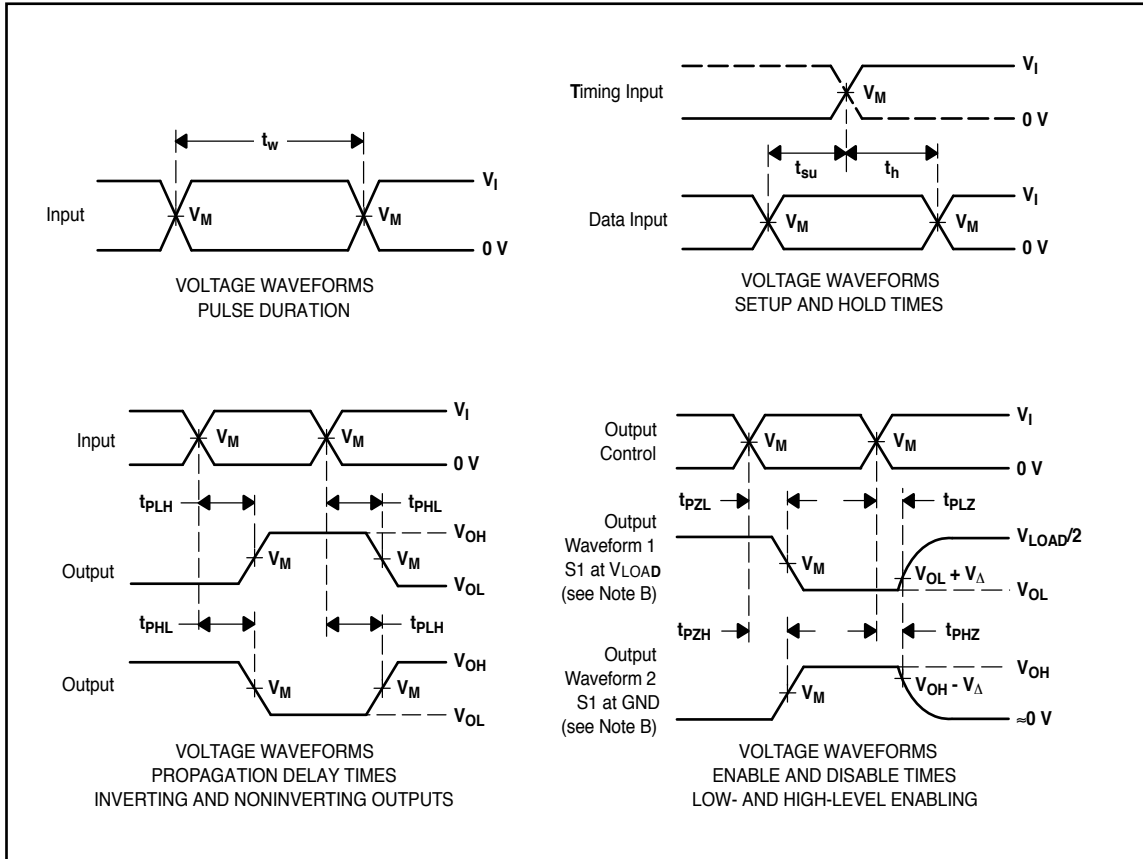

**Test Circuit**

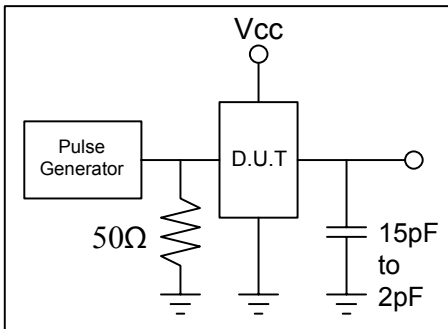

**54, 74 Series GHz Logic**

**Packaging Mechanical Drawing: 14 pin 150mil SOIC**

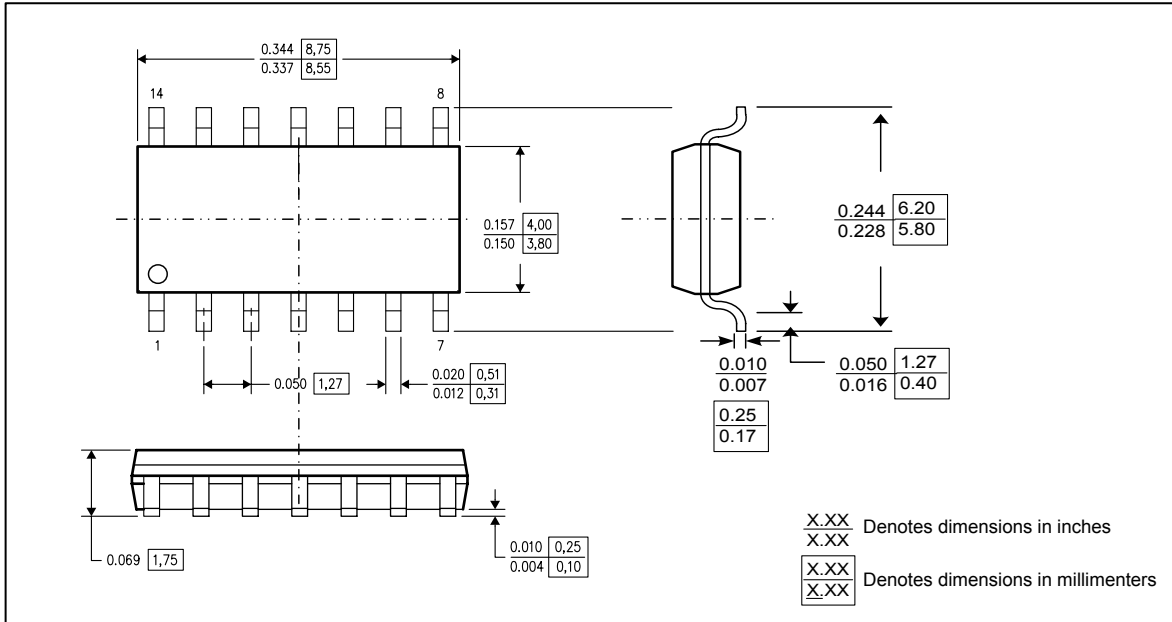

**Packaging Mechanical Drawing: 14pin Leadless Ceramic Chip Carrier**

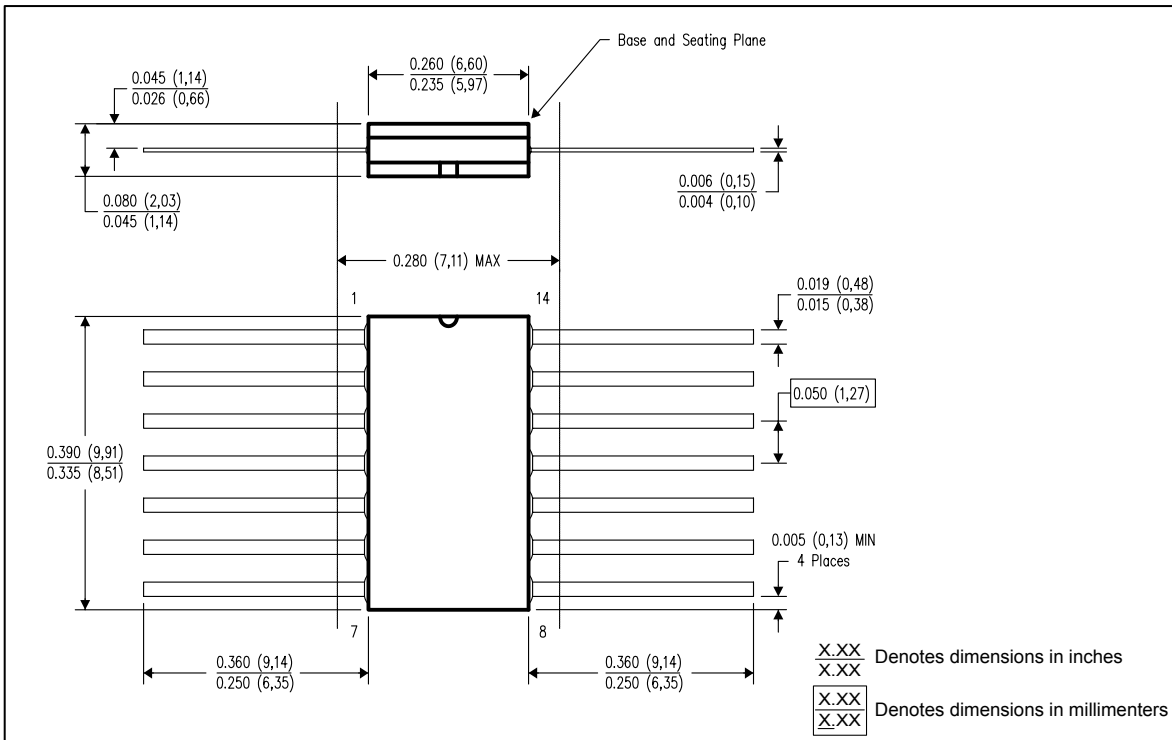

## 54, 74 Series GHz Logic

### Packaging Mechanical Drawing: 20pin Ceramic Dual Flatpack

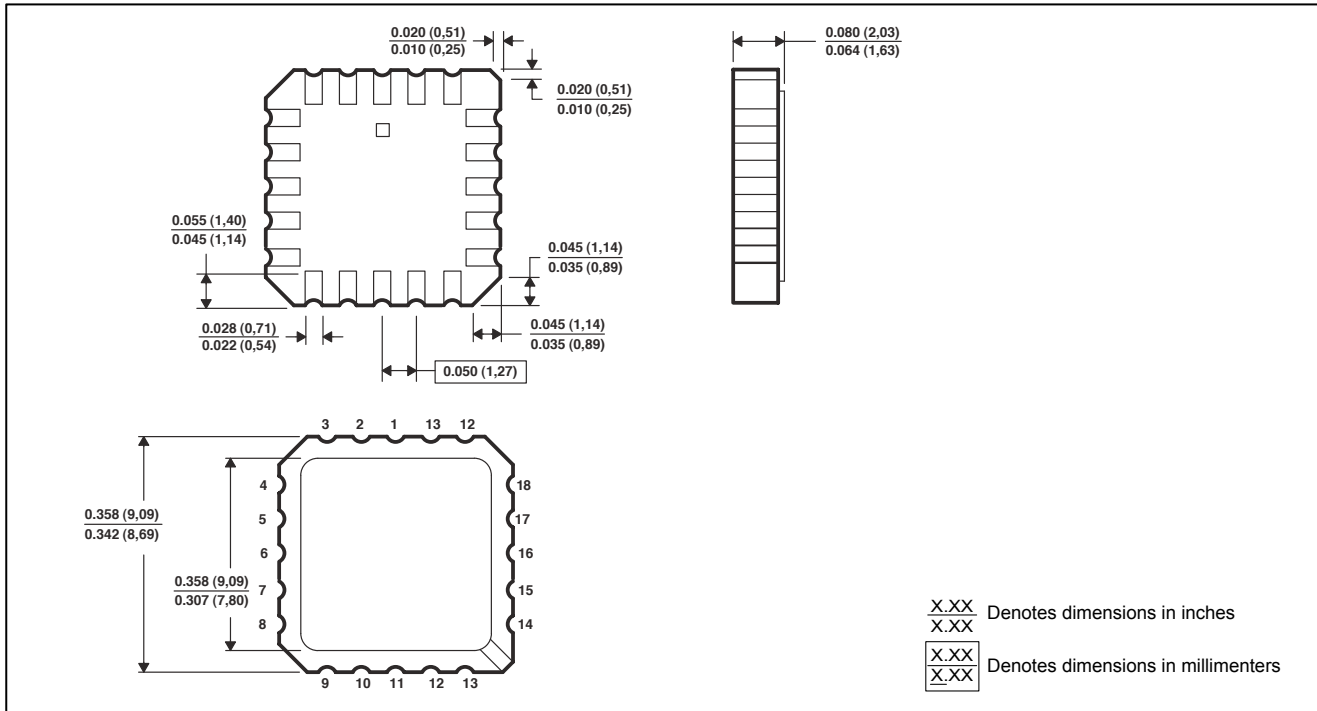

### Ordering Information

Ordering Code	Package			Top-Marking	T <sub>A</sub>
PO74G74ASU	14pin SOIC	Tube	Pb-free & Green	PO74G74AS	-40°C to 85°C
PO74G74ASR	14pin SOIC	Tape and reel	Pb-free & Green	PO74G74AS	-40°C to 85°C
PO74G74ASiU	14pin SOIC	Tube	Pb-free & Green	PO74G74ASi	-40°C to 125°C
PO74G74ASiR	14pin SOIC	Tape and reel	Pb-free & Green	PO74G74ASi	-40°C to 125°C
PO54G74ALU	14pin Leadless Ceramic Chip Carrier	Tube	Pb-free & Green	PO54G74AL	-55°C to 125°C
PO54G74AFU	20pin Ceramic Dual Flatpack	Tube	Pb-free & Green	PO54G74AF	-55°C to 125°C

### IC Package Information

PACKAGE CODE	PACKAGE TYPE	TAPE WIDTH (mm)	TAPE PITCH (mm)	PIN 1 LOCATION	TAPE TRAILER LENGTH	QTY PER REEL	TAPE LEADER LENGTH	QTY PER TUBE
S	SOIC 14	16	8	Top Left Corner	39 (12")	3000	64 (20")	55
L	LCCC 20	N/A	N/A	N/A	N/A	N/A	N/A	55
F	CFP 14	N/A	N/A	N/A	N/A	N/A	N/A	150