



FEATURES

- 2.5V~5.5V Power supply.
- Thermal shutdown Protection.
- Low current shutdown mode
- Low noise during turn-on and turn-off transitions.
- Support “Click and pop” suppression circuitry
- Lead free and green package available. (RoHS Compliant)
- Space Saving Package
 - MSOP 10 pin Package.
 - DFN 10 pin Package.

APPLICATION

- Portable and desktop computers
- Multimedia Monitors
- Portable Audio System

GENERAL DESCRIPTION

The LY8602 is a dual stereo audio power amplifier. It is capable of driving 4 Ω speaker load at a continuous average output of 2.0W / 10% distortion (THD+N) from a 5.5V power supply. The LY8602 primarily designed for high quality output power from application in other portable communication device and portable device.

The LY8602 audio amplifier features low power consumption in shutdown mode. It is achieved by driving the shutdown pin with logic low. And the LY8602 has an internal thermal shutdown protection feature.

To simplify audio system design of the LY8602. It is ideally suited for other low voltage applications or portable electronic devices where minimal power consumption is a primary requirement.

PIN CONFIGURATION

LY8602 MSOP10 Pin Configuration (Top View)

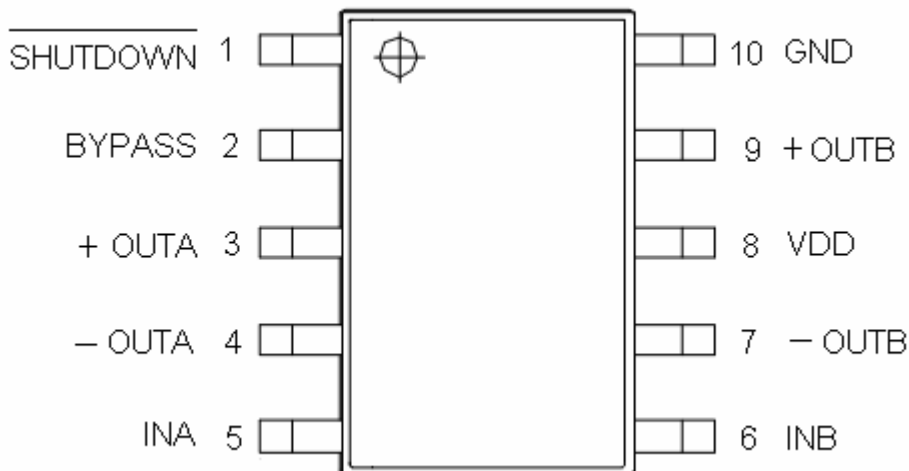

LY8602 DFN10 Pin Configuration (Top View)

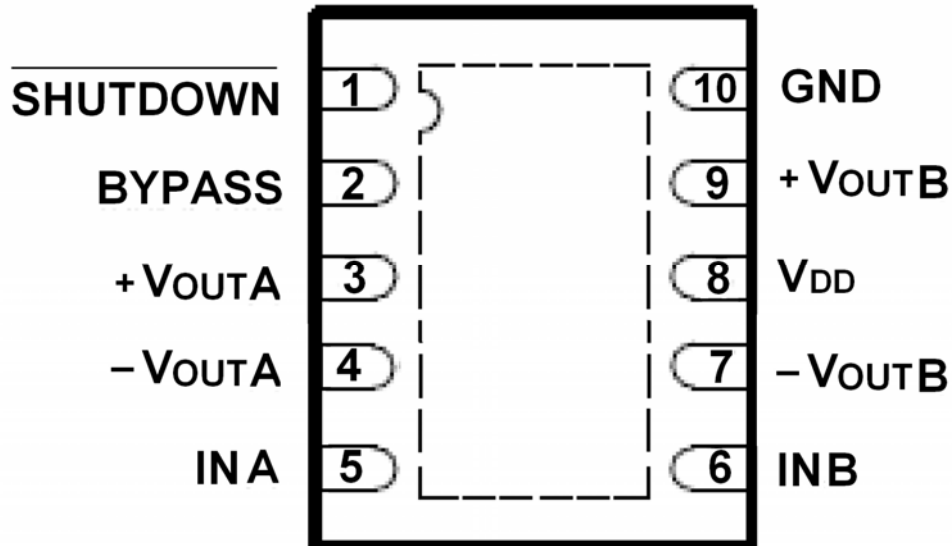

PIN DESCRIPTION

SYMBOL	Pin No.		DESCRIPTION
	MSOP	DFN	
SHUTDOWN	1	1	Shutdown control.(when low level is active the pin)
BYPASS	2	2	Bypass Pin
+OUTA	3	3	Positive BTL output of A channel.
-OUTA	4	4	Negative BTL output of A channel.
-INA	5	5	Negative Input of A channel.
-INB	6	6	Negative Input of B channel.
-OUTB	7	7	Negative BTL output of B channel.
V _{DD}	8	8	Power Supply
+OUTB	9	9	Positive BTL output of B channel.
GND	10	10	Ground

TYPICAL APPLICATION CIRCUIT

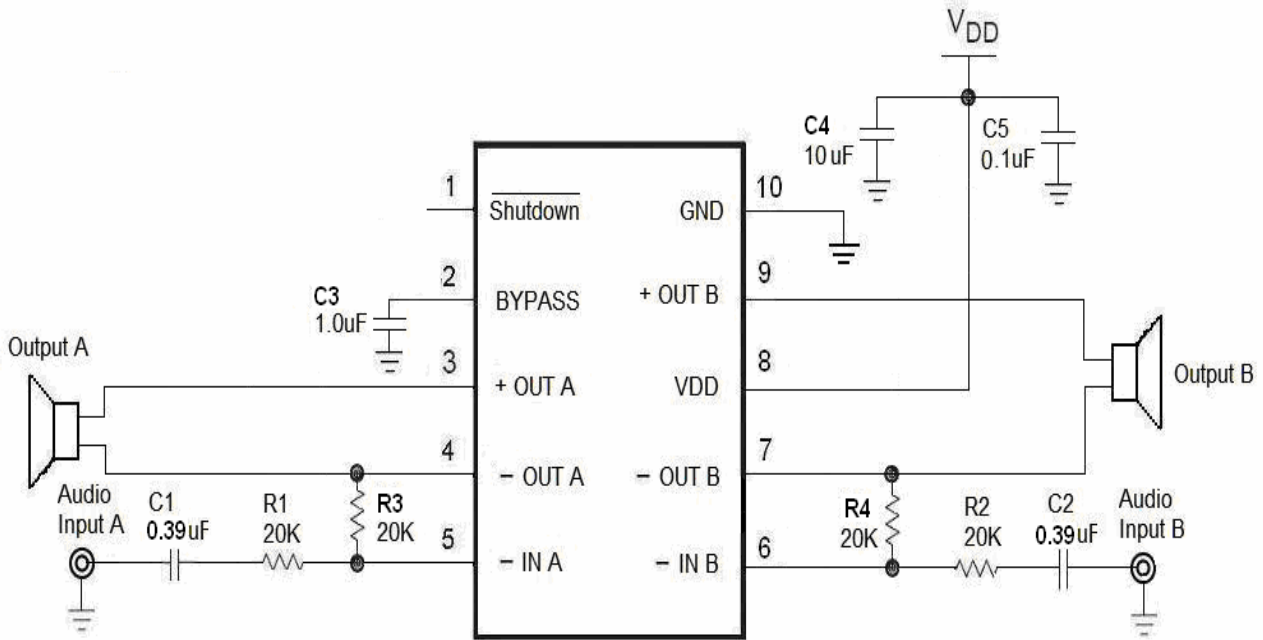

Figure 1. LY8602 Typical Application Circuit



ABSOLUTE MAXIMUM RATINGS*

PARAMETER	SYMBOL	RATING	UNIT
Supply Voltage	V _{DD}	6.0	V
Operating Temperature	T _A	-40 to 85 (I grade)	°C
Input Voltage	V _I	-0.3V to V _{DD} +0.3V	V
Storage Temperature	T _{STG}	-65 to 150	°C
Power Dissipation	P _D	Internally Limited	W
ESD Susceptibility	V _{ESD}	2000	V
Junction Temperature	T _{JMAX}	150	°C
Soldering Information	Vapor Phase (60 sec.)	215	°C
	Infrared (15 sec.)	220	

DC ELECTRICAL CHARACTERISTICS (V_{DD}=5V, T_A=25°C)

PARAMETER	SYMBOL	TEST CONDITION	MIN.	TYP.	MAX.	UNIT
Power Supply Current	I _{DD}	V _{IN} = 0V, I _O = 0A, 8Ω Load (BTL)	-	8.5	21.0	mA
Shutdown Current	I _{SD}	V _{SHUTDOWN} = 0V	-	0.3	2.0	μA
Shutdown High Input Voltage	V _{IH}		1.4	-	-	V
Shutdown Low Input Voltage	V _{IL}		-	-	0.4	V
Wake-up time	T _{WU}	Bypass cap.=1.0uF	-	172	-	ms
Output Offset Voltage	V _{OS}		-	7.0	50.0	mV
Output Power	P _O	THD = 1%, f = 1 kHz, R _L =8Ω		1.1		W
		THD = 10%, f = 1 kHz R _L =8Ω		1.4		
		THD = 1%, f = 1 kHz R _L =4Ω		1.4		
		THD = 10%, f = 1 kHz R _L =4Ω	-	1.8		
		THD = 10%, f = 1 kHz R _L =4Ω (at 5.5V)	-	2.0		
Total Harmonic Distortion+ Noise	THD+N	P _O = 0.4 Wrms; f = 1kHz, R _L =8Ω	-	0.11		%
Power Supply Rejection Ratio	PSRR	V _{ripple} = 200mV sine p-p Input terminated with 10Ω to GND		62 (f = 217Hz) 66 (f = 1kHz)	-	dB
Thermal Shutdown Temperature	T _{SD}		150	170	190	°C
Shutdown Time	T _{SdT}	8 Ω load		1.0		ms



DC ELECTRICAL CHARACTERISTICS (V_{DD}=3V, T_A=25°C)

PARAMETER	SYMBOL	TEST CONDITION	MIN.	TYP.	MAX.	UNIT
Power Supply Current	I _{DD}	V _{IN} = 0V, I _o = 0A, 8Ω Load (BTL)	-	6.3	15.5	mA
Shutdown Current	I _{SD}	V _{SHUTDOWN} = 0V	-	0.1	2.0	μA
Shutdown High Input Voltage	V _{IH}		1.4	-	-	V
Shutdown Low Input Voltage	V _{IL}		-	-	0.4	V
Wake-up time	T _{WU}	Bypass cap.=1.0uF	-	82	-	ms
Output Offset Voltage	V _{OS}		-	7.0	50	mV
Output Power	P _o	THD = 1%, f = 1 kHz, R _L =8Ω		0.37		W
		THD = 10%, f = 1 kHz R _L =8Ω		0.46		
		THD = 1%, f = 1 kHz R _L =4Ω		0.46		
		THD = 10%, f = 1 kHz R _L =4Ω	-	0.6		
Total Harmonic Distortion+ Noise	THD+N	P _o = 0.2 Wrms; f = 1kHz, R _L =8Ω	-	0.12		%
Power Supply Rejection Ratio	PSRR	V _{ripple} = 200mV sine p-p Input terminated with 10Ω to GND		56 (f = 217Hz) 62 (f = 1kHz)	-	dB
Thermal Shutdown Temperature	T _{SD}		150	170	190	°C
Shutdown Time	T _{SdT}	8 Ω load		1.0		ms

ORDERING INFORMATION

LY 8 602 VV

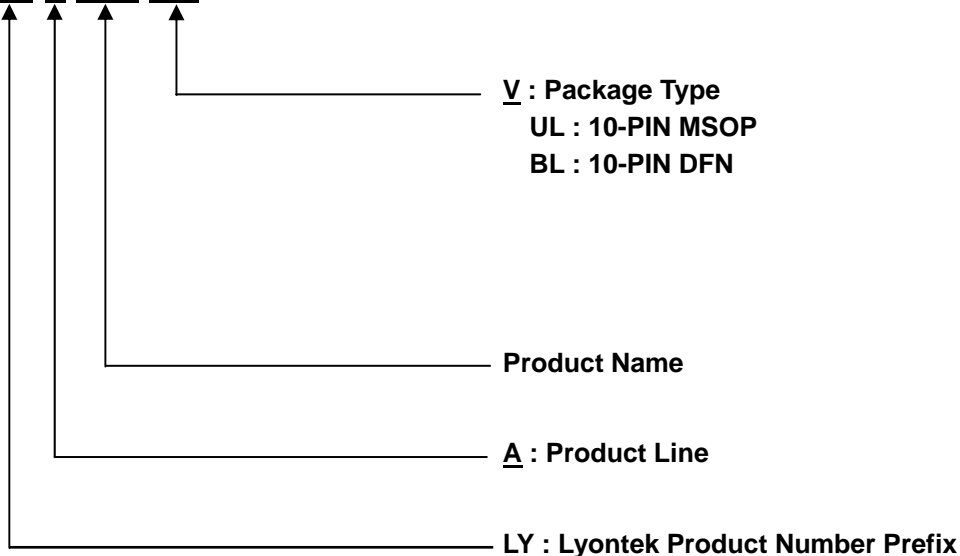

APPLICATION INFORMATION

POWER SUPPLY BYPASSING

As with any power amplifier, proper supply bypassing is critical for low noise performance and high power supply rejection. Applications that employ a 5V regulator typically use a 10 μF in parallel with a 0.1 μF filter capacitor to stabilize the regulator's output, reduce noise on the supply line, and improve the supply's transient response. However, their presence does not eliminate the need for a local 1.0 μF tantalum bypass capacitance connected between the LY8602's supply pins and ground. Do not substitute a ceramic capacitor for the tantalum. Doing so may cause oscillation. Keep the length of leads and traces that connect capacitors between the LY8602's power supply pin and ground as short as possible.

MICRO-POWER SHUTDOWN

The voltage applied to the SHUTDOWN pin controls the LY8602's shutdown function. Activate micro-power shutdown by applying GND to the SHUTDOWN pin. When active, the LY8602's micro-power shutdown feature turns off the amplifier's bias circuitry, reducing the supply current. The low 0.1 μA typical shutdown current is achieved by applying a voltage that is as near as GND as possible to the SHUTDOWN pin.

Bypass Capacitor Value Selection

Besides minimizing the input capacitor size, careful consideration should be paid to value of C3, the capacitor connected to the BYPASS pin. Since C3 determines how fast the LY8602 settles to quiescent operation, its value is critical when minimizing turn-on pops. The slower the LY8602's outputs ramp to their quiescent DC voltage (nominally 1/2 VDD), the smaller the turn-on pop. Choosing C6 equal to 1.0 μF along with a small value of C1,C2 (in the range of 0.1 μF to 0.39 μF), produces a click-less and pop-less shutdown function. As discussed above, choosing C1,C2 no larger than necessary for the desired bandwidth helps minimize clicks and pops.

OPTIMIZING CLICK AND POP REDUCTION PERFORMANCE

The LY8602 contains circuitry that minimizes turn-on and shutdown transients or "clicks and pop". For this discussion, turn-on refers to either applying the power supply voltage or when the shutdown mode is deactivated. When the part is turned on, an internal current source changes the voltage of the BYPASS pin in a controlled, linear manner. Ideally, the input and outputs track the voltage applied to the BYPASS pin. The gain of the internal amplifiers remains unity until the voltage on the bypass pin reaches 1/2 VDD. As soon as the voltage on the bypass pin is stable, the device becomes fully operational. Although the BYPASS pin current cannot be modified, changing the size of C3 alters the device's turn-on time and the magnitude of "clicks and pops". Increasing the value of C3 reduces the magnitude of turn-on pops. However, this presents a tradeoff: as the size of C3 increases, the turn-on time increases. There is a linear relationship between the size of C3 and the turn-on time. Here are some typical turn-on times for various values of C3: In order eliminate "clicks and pops", all capacitors must be discharged before turn-on. Rapidly switching VDD on and off may not allow the capacitors to fully discharge, which may cause "clicks and pops". In a single-ended configuration, the output is coupled to the load by C1,C2. This capacitor usually has a high value. C1,C2 discharges through internal 20k Ω resistors. Depending on the size of C1,C2, the discharge time constant can be relatively large. To reduce transients in single-ended mode, an external 1k Ω - 5k Ω resistor can be placed in parallel with the internal 20k Ω resistor. The tradeoff for using this resistor is increased quiescent current.

TABLE 2. C3 and Ton Truth Table

C3	T _{ON} (Typ.) at 5.0V
1.0 μF	172 ms
0.47 μF	76 ms
0.33 μF	60 ms
0.22 μF	50 ms
0.1 μF	36 ms

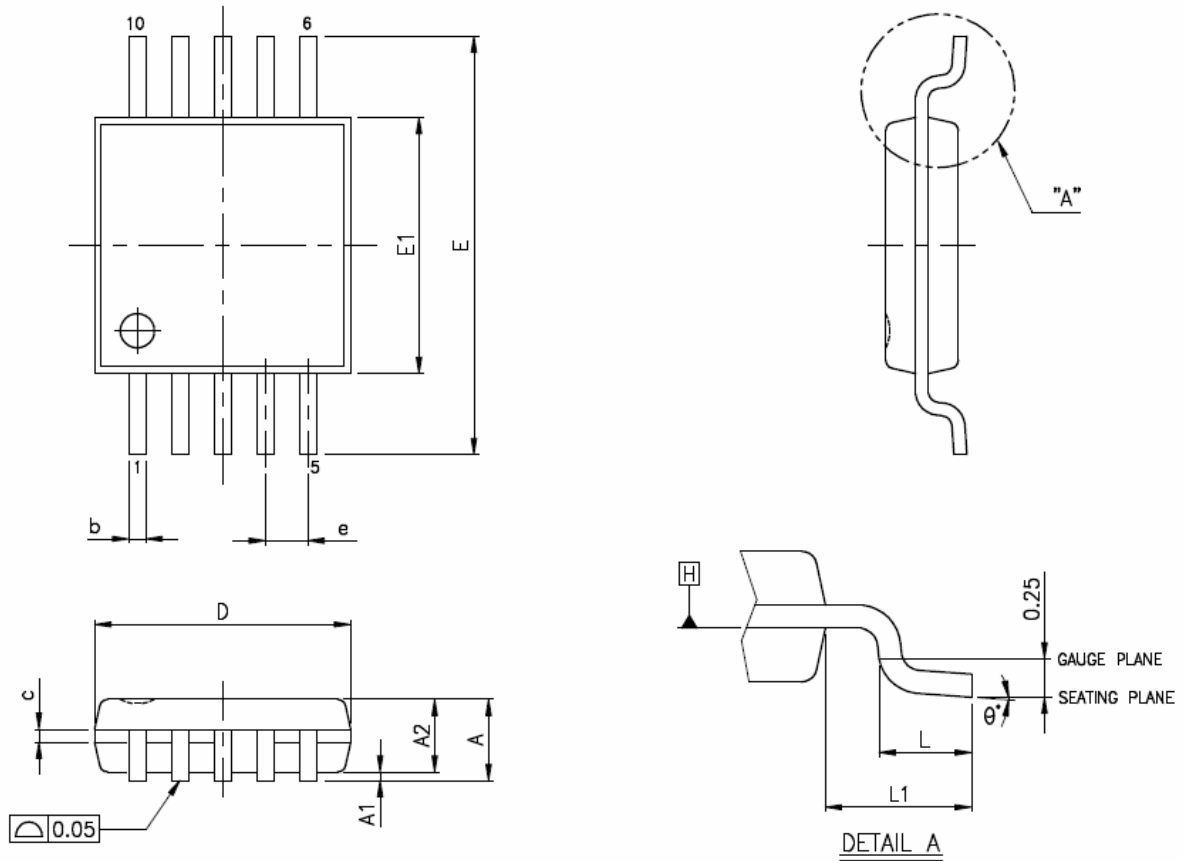
PACKAGE OUTLINE DIMENSION
10-Pin MSOP Package Outline Dimension

SYMBOLS	MIN.	NOM.	MAX.
A	—	—	1.10
A1	0.00	—	0.15
A2	0.75	0.85	0.95
b	0.17	—	0.27
c	0.08	—	0.23
D	3.00 BSC		
E	4.90 BSC		
E1	3.00 BSC		
e	0.50 BSC		
L	0.40	0.60	0.80
L1	0.95 REF		
θ^*	0	—	8

UNIT : MM

10-Pin DFN Package Outline Dimension

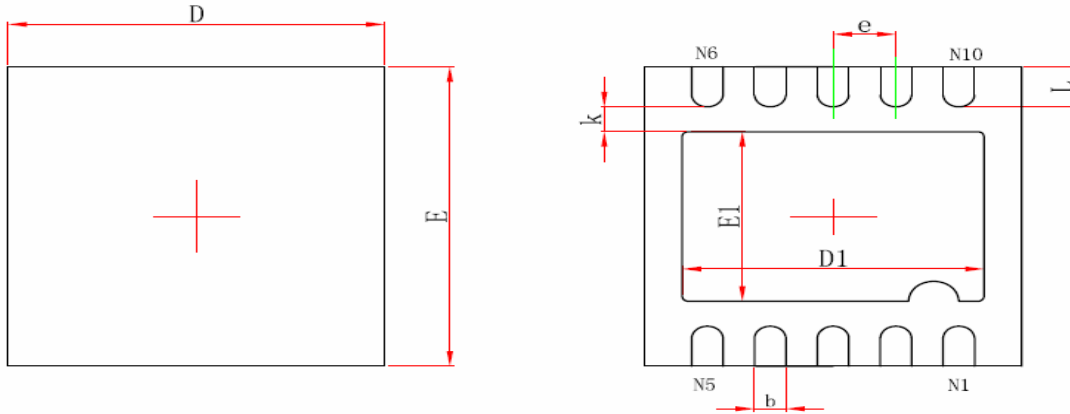

Top View

Bottom View

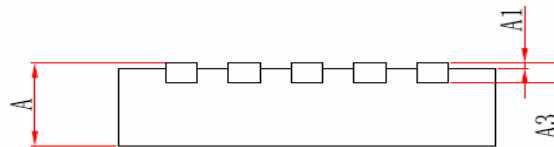

Side View

Symbol	Dimensions In Millimeters	
	Min.	Max.
A	0.700/0.800	0.800/0.900
A1	0.000	0.050
A3	0.203REF.	
D	2.900	3.100
E	2.900	3.100
D1	2.300	2.500
E1	1.600	1.800
k	0.200MIN.	
b	0.180	0.300
e	0.500TYP.	
L	0.300	0.500